



HURON-CLINTON METROPARKS ADA TRANSITION PLAN

Administrative Office
13000 High Ridge Drive
Brighton, MI 48114



[METROPARKS.COM](https://www.metroparks.com)



TABLE OF CONTENTS

Introduction	4
Transition Plan Need & Purpose	4
Transition Plan Development	6
Facilities	9
Playgrounds	10
Programming	11
Signage	12
ADA Coordinator & Grievance Procedures	13
Public Participation	14
Conclusion.	15
Appendix 1: ADA Checklist	
Appendix 2: Facilities Transition Plan	
Appendix 3: Picnic Facilities Maps	
Appendix 4: Picnic Facilities Prioritized by Park	
Appendix 5: Playground Transition Plan	
Appendix 6: Programming Transition Plan	
Appendix 7: Public Input Summary	

INTRODUCTION

TRANSITION PLAN NEED & PURPOSE

The Metroparks is committed to regularly revisiting and assessing operations and facilities to ensure compliance with the Americans with Disabilities Act of 1990.

The Americans with Disabilities Act (ADA) is a civil rights law prohibiting discrimination against individuals based on disability.

The required contents of an ADA transition plan are:

1. Identification of physical obstacles that limit accessibility to programs, services, and activities;
2. The method to be used to make the facilities accessible;
3. A schedule for making modifications; and
4. The name of the public official responsible for the implementation of the transition plan.



Although original accessibility guidelines applicable to local municipalities were published in 1990, several additions related to recreation facilities were added between 2000-2004. Given these additions, parallels between these guidelines and the Architectural Barriers Act Accessibility Guidelines, which are applied to a building if any federal monies or uses are involved, a combined version of the ADA-ABA was introduced in 2004. During this timeframe, outdoor standards were also created to apply ADA standards to outdoor natural environments in addition to structures that were built. These standards are known as the Federal Outdoor Area Technical Guidelines. Although these standards are currently only enforceable for federal facilities, they provide the Metroparks with best practice guidelines to meet inclusive policy and philosophy goals.

The combined ADA-ABA guidelines resulted in the 2010 Accessibility Standards, which were adopted as one comprehensive universal standard for federal and local jurisdictions in July 2010 and posted to the Federal Register in September 2010. The 2010 Accessibility Standards hereafter referenced as “2010 Standards” became enforceable in March 2012.



INTRODUCTION

TRANSITION PLAN DEVELOPMENT

In 2018, the Metroparks Planning and Development Department revisited the Authority's 1994 ADA Transition Plan and conducted a thorough assessment of all physical barriers within the 13 Metroparks.

The 2010 Standards address common elements of the “built environment,” such as buildings, parking lots and access routes, as well as recreational facilities such as amusement rides, play equipment, boat docks and launches, fishing piers, swimming pools, golf and mini-golf courses and shooting facilities.

While they have not yet been adopted for state and local governments, guidelines for developed outdoor areas have been introduced. In 2013, these guidelines became enforceable standards for all federally-owned areas. Experts expect these same guidelines will eventually be adopted for state and local governments as well.

Within the 2010 standards, the U.S. Department of Justice (DOJ) recommended the following priorities, in order for barrier removal:

1. Approach and Entrance – parking lots, transit stops, exterior access routes, building entrances, etc.
2. Access to Goods and Services – service counters, seating areas, etc.
3. Toilet Facilities – including bathing facilities
4. Additional Access – telephone, drinking fountains, and alarm systems

This priority system was developed for private owners of places for public accommodation (such as retailers, restaurants and spectator facilities) and applies primarily to building sites with one main entry point.

As written, the priority system developed by the DOJ does not work well for open areas with different types of recreation opportunities throughout the park. However, using the rationale behind their development, they can be modified to create a priority ranking for park and recreation facilities in the table below.

In this modified system, the first priority identified by the DOJ, “Approach and Entrance,” was defined as the park entrances, restroom entrances, the larger day-use parking lots within the parks and the access routes from those parking lots to

the primary facilities they serve. The second through fourth priorities addresses recreational opportunities at the parks. The fifth priority is defined as non-essential support, facility services. The sixth priority has been assigned to physical barriers in structures that have been identified in master plans needing further study. Finally, the seventh priority refers to physical barriers that would impede a park employee but not the general public.

PRIORITY RANKING	
1	Primary recreational visitor approach and entrance areas Areas with primary approach and entrances for visitors to parks that include parking lots, building entrance, facility approach, picnic shelters
2	Access to Goods and Services recreational visitor areas Service counters, seating areas, golf patios, outdoor food bars
3	Restrooms that support primary recreational visitor areas Restrooms
4	Secondary recreational visitor approach and entrance areas Mountain biking, equestrian trails, disc golf, picnic areas (non-shelter), water refill stations
5	Non-essential park user recreational support, facility services Park office, administrative office, rental center, concessions, police
6	Facilities needing further study for future use, renovation, replacement, or removal Facilities identified in 10-year master plans needing further study for future use, renovation, replacement, or removal
7	Physical structural barriers in facilities that impede park employees but not the general public Maintenance areas, dam facilities

The integration of the transition plan with master planning and capital improvement planning is key to completing the tasks identified in the transition plan. In fiscal year 2019, the Metroparks included a general funding line item for each park for accessibility improvements in the general budget.

Moving forward, top priority projects will be added into annual capital and major maintenance improvement projects and identified in the Five-Year Community Recreation Plan and 10-year master plan (five-year amended) developments. The appendices detail specific actions to be taken at each Metropark. They are listed by priority ranking as outlined above.

The Metroparks is currently developing a Recreation Programming Plan, which will incorporate the accessibility initiative. Planning and Development staff will work with other Metroparks departments to develop a separate signage transition plan in 2020.

FACILITIES

The most recent park maps were used to identify all facilities within each planning area. Field surveying was completed by Planning and Development staff for facilities based on the 2010 standards checklist from the New England ADA Center (see Appendix 1. ADA Checklist). Survey data was entered into a spreadsheet for each facility. Once assessments were completed, each facility was prioritized based on the seven DOJ rankings (customized for the Metroparks) and further analyzed based on other factors including the highest number of deficiencies, high activity facilities, and equity-based on associated fees with certain facilities (see Appendix 2. Facilities Transition Plan).

Picnic facilities were defined as part of the ADA facilities transition plan. A picnic facility is a site or a portion of a site, that is developed for outdoor recreational purposes and contains picnic units. A picnic unit is an outdoor space in a picnic facility that is used for picnicking and contains at least one outdoor constructed feature. Picnic units with shelters were ranked higher than picnic units without shelters based on the methodology used in the prioritization. The priority rankings for picnic units include maps depicting picnic facilities within the parks and the dispersing of picnic units (see Appendix 3. Picnic Facility Maps).

A prioritization of picnic units by each park can be found in the GIS dataset (see Appendix 4. Picnic Units Prioritized by Park).

PICNIC FACILITY RECOMMENDATION

When only one or two picnic units are provided in a picnic facility, each picnic unit must provide mobility features. When more than two picnic units are provided in a picnic facility, at least 20 percent, but no less than two, of the picnic units must provide mobility features (2010 standards). Metroparks picnic facilities should meet the standards and go beyond by ensuring all picnic units with shelters are made accessible and a minimum of two picnic units outside shelters dispersed within the facility be made accessible.

PICNIC UNIT RECOMMENDATION

Picnic units typically contain tables and grills (constructed features). The ADA Transition Plan is a snapshot in time with picnic unit elements subject to change based on events and activities. When updating, an accessible route and surface around accessible grills and picnic tables and other elements is required. A conceptual site plan should be developed by Planning and Development staff and reviewed by Park Operations prior to redeveloping picnic units.

PLAYGROUNDS

Certified Playground Safety Inspectors performed assessments on playground barriers. Assessments of playgrounds include a thorough safety inspection per established standards, an examination of the slopes and clear space in and around the play area, and an inventory of play components (elevated and ground level). Staff also performed ADA assessments with the checklist provided for play structures based on the 2010 Standards.

The Metroparks 2018-2022 Community Recreation Plan includes an inventory of all playgrounds in each park. ADA assessments were conducted for large playgrounds where a quantity and variety of play elements typically are located. The goal is to ensure full accessibility at these large playgrounds and to ensure that like play experiences are provided for all abilities. In some cases it may be feasible to either add an accessible walkway to small play areas or relocate them in accessible clusters.

Large playground areas with physical barriers are addressed in this transition plan but are not ranked based on the priority system used for facilities (see Appendix 5. Playground Transition Plan). The checklist from the New England ADA Center was adapted and used in the field evaluations of large playgrounds in the parks. The checklist results were used to develop a rating for each facility, shown in a table for each park. The rating system is as follows:

1. no elements are accessible
2. some elements are accessible
3. most elements are accessible
4. all elements are accessible
5. facility follows Universal Design principles



PROGRAMMING

The Metroparks is also embarking upon an amendment to the 2018-2022 Community Recreation Plan that will include a Recreation Programming Plan. This transition plan is a living document and will integrate the programming action items once identified in the Recreation Programming Plan action plan. This plan will be drafted and reviewed by respective staff engaged in a self-evaluation of all Metroparks programming and services offered by Interpretive Services, Natural Resources, Golf, Police and Marketing. Each department will categorize its programming into groups of similar types of activities (e.g. programs, events, activities) and then analyze each activity in terms of vision, hearing, and mobility barriers that may exist (see Appendix 6. Programming Transition Plan). The resulting actions will be in a spreadsheet format that identifies any necessary modifications and establishes timelines as to when the modifications would be completed. As one of its first action items, the Metroparks will create an accessibility webpage, which will be organized to include all of the information related to accessibility in one location. Information related to the Metroparks accessibility practices will include both the availability of regular programming available to individuals with disabilities, and the custom and adaptive programming that could be made available including, but not limited to, birding, fishing, hand-cycling, nature appreciation hikes, photography, snowshoeing, adaptive paddling, kayaking, canoeing, stand-up paddle boarding, camping and mobility services for golfing. Cognitive barriers are addressed mostly on a case-by-case basis, as experience has proven that solutions for individuals with cognitive disabilities are fact-driven and very case-specific.



SIGNAGE

The Marketing and Planning and Development departments are engaged in a comprehensive review of Section 216 and 703 of the ADA Standards to incorporate in an ADA Signage Compliance Manual.

This manual will be used as a tool to ensure that all existing and future signage that is created or ordered for use at the Huron-Clinton Metroparks will comply with all applicable ADA standards. The completion date is anticipated sometime in 2020.



ADA COORDINATOR & GRIEVANCE PROCEDURES

The Chief of Diversity, Equity, and Inclusion serves as the ADA Coordinator for the Huron-Clinton Metroparks. In the ADA Coordinator capacity, she also oversees the Grievance Procedure which contains the following provisions. Complaints are to be filed, in writing if possible, containing sufficient facts to investigate. The complaint must be submitted no later than sixty (60) calendar days after the alleged violation to:

Artina Sadler
Chief of Diversity, Equity and Inclusion (DEI)
(810) 819-7540
artina.sadler@metroparks.com
13000 High Ridge Drive
Brighton, Michigan 48114



PUBLIC PARTICIPATION

The public participation process is critical prior to adoption of the Transition Plan and is a federal requirement that stakeholders be included in the process of developing the Transition Plan.

Recent planning efforts gathered public input and stakeholder feedback on prioritizing facilities, programs and amenities and identifying accessibility opportunities and issues.

The 2018-2022 Metroparks Community Recreation Plan was approved by the Huron-Clinton Metropolitan Authority (HCMA) Board of Commissioners by resolution on September 14, 2017. Similar to the individual park master plans, community input was solicited during the entire planning process. Stakeholder meetings were held for each of the three park districts of the Metroparks system – Eastern, Western and Southern. The Metroparks also worked with a consultant to conduct a formal survey targeting a representative sample of the southeast Michigan community geared toward both individuals who currently use the parks and those who do not use the parks but may have unmet recreational needs.

The Metroparks is also in the process of creating a Recreation Programming Plan as an addendum to the 2018-2022 Community Recreation Plan. Currently, more than 2,300 participants have provided public input on the types of programs that are most important to visitors. The Transition Plan obtained further input with an online survey, an email blast with a brief questionnaire to stakeholder groups and posting of the draft plan for two weeks on the Metroparks website for public comments. The results of the public input process were taken into account when determining which types of facilities to prioritize and in prioritizing the elements within the facilities. Summary of the public input process, online survey and questionnaire are provided (see Appendix 7. Public Input Summary).



CONCLUSION

The Metroparks is committed to providing safe and accessible facilities and services to all citizens. Consistent with the Americans with Disabilities Act (ADA) regulations, the Metroparks will ensure that there is no discrimination against individuals on the basis of disability in its programs and services.

The Metroparks will implement the Transition Plan as outlined and will continue to look for ways to remove barriers to access so that individuals with disabilities have equitable access to Metroparks programs, services, and activities. The Metroparks will follow-up on corrective actions recommended by the Transition Plan, by continually updating the Transition Plan documenting its efforts in compliance with the ADA.

While the Metroparks will undertake capital improvements to address the items in the Transition Plan, the agency will also address ADA standards throughout its programs and services in the following ways:

1. Through design and construction guidelines and standards that ensure that all new construction is ADA compliant and that all capital improvements consider the needs of all users;
2. Every five years updating its ADA Transition Plan to reflect capital programming and planning and to ensure the Metroparks is making significant progress in addressing accessibility needs;
3. By ensuring ADA compliance when Metroparks facilities are maintained and upgraded;
4. Through ongoing education and training of Metroparks staff.



APPENDIX 1: ADA CHECKLIST



ADA Checklist for Existing Facilities

Priority 1 – Approach & Entrance

Based on the 2010 ADA Standards for Accessible Design



Project _____

Building _____

Location _____

Date _____

Surveyors _____

Contact Information _____

An accessible route from site arrival points and an accessible entrance should be provided for everyone.



Institute for Human Centered Design
www.HumanCenteredDesign.org

Copyright © 2016



ADA National Network
Questions on the ADA 800-949-4232 voice/tty
www.ADAchecklist.org

This checklist was produced by the New England ADA Center, a project of the Institute for Human Centered Design and a member of the ADA National Network. This checklist was developed under a grant from the Department of Education, NIDRR grant number H133A060092-09A. However the contents do not necessarily represent the policy of the Department of Education, and you should not assume endorsement by the Federal Government.



Questions or comments on the checklist contact the New England ADA Center at 617-695-0085 voice/tty or ADAinfo@NewEnglandADA.org



For the full set of checklists, including the checklists for recreation facilities visit www.ADAchecklist.org.

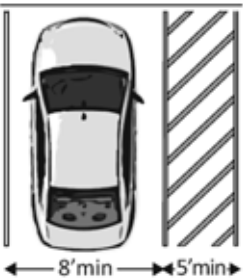
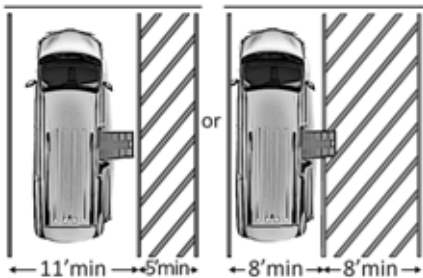
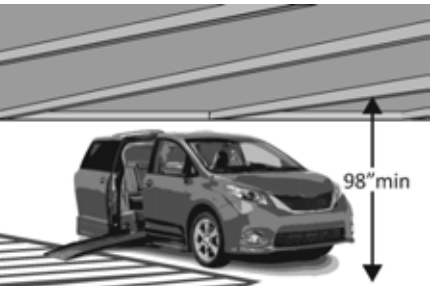

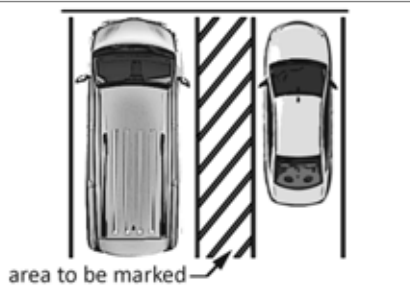
Copyright © 2016 ADA Checklist for Existing Materials. You can freely reproduce and distribute this content. Include proper attribution. But you must get permission before using this content as a fee-based product.

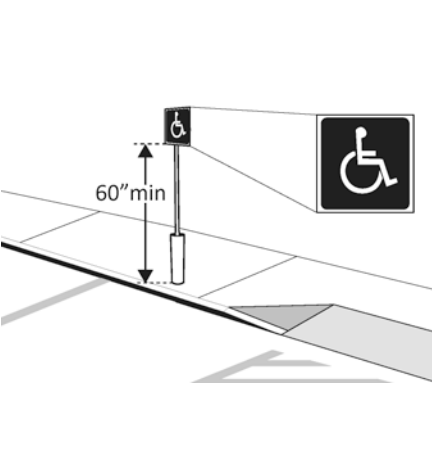
Priority 1 – Approach & Entrance		Comments	Possible Solutions												
<p>1.1 Is there at least one route from site arrival points (parking, passenger loading zones, public sidewalks and public transportation stops) that does not require the use of stairs? [See 2010 ADA Standards for Accessible Design – 206.2.1]</p>	<p><input type="checkbox"/> Yes <input type="checkbox"/> No</p> <p>If yes, location of route:</p>	<p>Photo #:</p>	<ul style="list-style-type: none"> • Add a ramp • Regrade to 1:20 maximum slope • Add a lift if site constraints prevent other solutions 												
<p>Parking Accessible parking spaces should be identified by size, access aisle and signage.</p>															
<p>1.2 If parking is provided for the public, are an adequate number of accessible spaces provided? [208.2]</p>	<p><input type="checkbox"/> Yes <input type="checkbox"/> No</p> <p>Total #: Accessible #:</p>	<table border="1"> <thead> <tr> <th>Total Spaces</th> <th>Accessible Spaces</th> </tr> </thead> <tbody> <tr> <td>1 - 25</td> <td>1</td> </tr> <tr> <td>26 - 50</td> <td>2</td> </tr> <tr> <td>51 - 75</td> <td>3</td> </tr> <tr> <td>76 - 100</td> <td>4</td> </tr> <tr> <td colspan="2">100+ see 2010 Standards 208.2</td> </tr> </tbody> </table> <p>Photo #:</p>	Total Spaces	Accessible Spaces	1 - 25	1	26 - 50	2	51 - 75	3	76 - 100	4	100+ see 2010 Standards 208.2		<ul style="list-style-type: none"> • Reconfigure by repainting lines • •
Total Spaces	Accessible Spaces														
1 - 25	1														
26 - 50	2														
51 - 75	3														
76 - 100	4														
100+ see 2010 Standards 208.2															
<p>1.3 Of the accessible spaces, is at least one a van accessible space?*[208.2.4]</p>	<p><input type="checkbox"/> Yes <input type="checkbox"/> No</p>	<p>*For every 6 or fraction of 6 parking spaces required by the table above, at least 1 should be a van accessible space.</p> <p>Photo #:</p>	<ul style="list-style-type: none"> * If constructed before 3/15/2012, parking is compliant if at least 1 in every 8 accessible spaces is van accessible • Reconfigure by repainting lines 												

<p>1.4 Are accessible spaces at least 8 feet wide with an access aisle at least 5 feet wide? [502.2, 502.3]</p> <p>Note: Two spaces may share an access aisle. Check state/local requirements; some specify that each space have its own aisle.</p>	<p><input type="checkbox"/> Yes <input type="checkbox"/> No</p> <p>Measurement:</p>		<p>Photo #:</p>	<ul style="list-style-type: none"> • Reconfigure by repainting lines • •
<p>1.5 Is the van accessible space:</p> <p>At least 11 feet wide with an access aisle at least 5 feet wide? Or At least 8 feet wide with an access aisle at least 8 feet wide? [502.2]</p>	<p><input type="checkbox"/> Yes <input type="checkbox"/> No</p> <p>Measurement:</p> <p><input type="checkbox"/> Yes <input type="checkbox"/> No</p> <p>Measurement:</p>		<p>Photo #:</p>	<ul style="list-style-type: none"> • Reconfigure to provide van-accessible space(s) • •
<p>1.6 Is at least 98 inches of vertical clearance provided for the van accessible space? [502.5]</p>	<p><input type="checkbox"/> Yes <input type="checkbox"/> No</p> <p>Measurement:</p>		<p>NA</p> <p>Photo #:</p>	<ul style="list-style-type: none"> • Reconfigure to provide van-accessible space(s) • •

<p>1.7 Are the access aisles marked so as to discourage parking in them? [502.3.3]</p> <p>Note: The marking method and color may be addressed by state/local requirements.</p>	<p><input type="checkbox"/> Yes <input type="checkbox"/> No</p>		<p>Photo #:</p>	<ul style="list-style-type: none"> • Mark access aisles • •
<p>1.8 Is the slope of the accessible parking spaces and access aisles no steeper than 1:48 in all directions? [502.4]</p>	<p><input type="checkbox"/> Yes <input type="checkbox"/> No</p> <p>Measurement:</p>		<p>Photo #:</p>	<ul style="list-style-type: none"> • Regrade surface • •
<p>1.9 Do the access aisles adjoin an accessible route? [502.3]</p>	<p><input type="checkbox"/> Yes <input type="checkbox"/> No</p>		<p>Photo #:</p>	<ul style="list-style-type: none"> • Create accessible route • Relocate accessible space •
<p>1.10 Are accessible spaces identified with a sign that includes the International Symbol of Accessibility? Is the bottom of the sign at least 60 inches above the ground? [502.6]</p> <p>Note: The International Symbol of Accessibility is not required on the ground.</p>	<p><input type="checkbox"/> Yes <input type="checkbox"/> No</p> <p><input type="checkbox"/> Yes <input type="checkbox"/> No</p> <p>Measurement:</p>		<p>Photo #:</p>	<ul style="list-style-type: none"> • Install signs • •

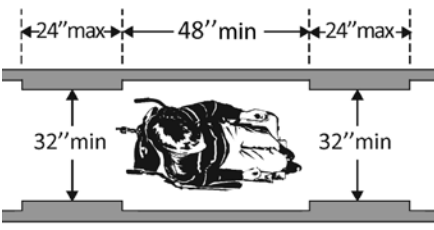
<p>1.11 Are there signs reading “van accessible” at van accessible spaces? [502.6]</p>	<p><input type="checkbox"/> Yes <input type="checkbox"/> No</p>		<p>Photo #:</p>	<ul style="list-style-type: none"> • Install signs • •
<p>1.12 Of the total parking spaces, are the accessible spaces located on the closest accessible route to the accessible entrance(s)? [208.3.1]</p> <p>Note: If parking serves multiple entrances, accessible parking should be dispersed.</p>	<p><input type="checkbox"/> Yes <input type="checkbox"/> No</p>		<p>Photo #:</p>	<ul style="list-style-type: none"> • Reconfigure spaces • •
<p>Exterior Accessible Route</p>				
<p>1.13 Is the route stable, firm and slip-resistant? [302.1]</p>	<p><input type="checkbox"/> Yes <input type="checkbox"/> No</p>		<p>Photo #:</p>	<ul style="list-style-type: none"> • Repair uneven paving • Fill small bumps and breaks with patches • Replace gravel with asphalt or other surface
<p>1.14 Is the route at least 36 inches wide? [403.5.1]</p>	<p><input type="checkbox"/> Yes <input type="checkbox"/> No</p> <p>Measurement:</p>			<ul style="list-style-type: none"> • Change or move landscaping, furnishings or other items • Widen route •

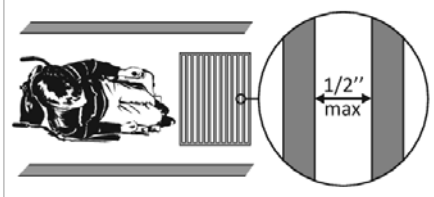
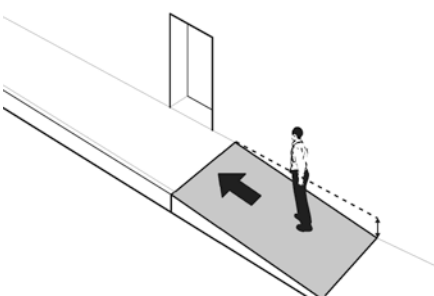
<p>Note: The accessible route can narrow to 32 inches min. for a max. of 24 inches. These narrower portions of the route must be at least 48 inches from each other.</p>			<p>Photo #:</p>	
<p>1.15 If the route is greater than 200 feet in length and less than 60 inches wide, is there a passing space no less than 60 x 60 inches? [403.5.3]</p>	<p><input type="checkbox"/> Yes <input type="checkbox"/> No</p> <p>Measurement:</p>		<p>Photo #:</p>	<ul style="list-style-type: none"> • Widen route for passing space • •
<p>1.16 If there are grates or openings on the route, are the openings no larger than 1/2 inches?</p> <p>Is the long dimension perpendicular to the dominant direction of travel? [302.3]</p>	<p><input type="checkbox"/> Yes <input type="checkbox"/> No</p> <p>Measurement:</p> <p><input type="checkbox"/> Yes <input type="checkbox"/> No</p>		<p>Photo #:</p>	<ul style="list-style-type: none"> • Replace or move grate • •
<p>1.17 Is the running slope no steeper than 1:20, i.e. for every inch of height change there are at least 20 inches of route run? [403.3]</p> <p>Note: If the running slope is steeper than 1:20, treat as a ramp and add features such as edge protection and handrails.</p>	<p><input type="checkbox"/> Yes <input type="checkbox"/> No</p> <p>Measurement:</p>		<p>Photo #:</p>	<ul style="list-style-type: none"> • Regrade to 1:20 max. • •

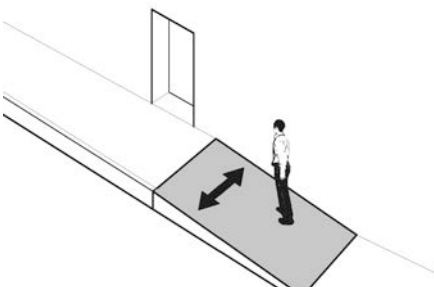
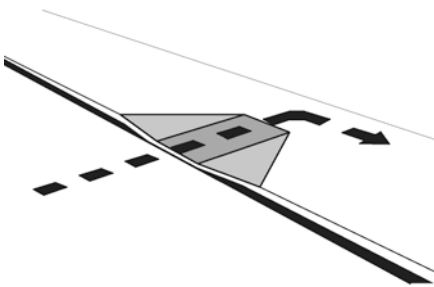
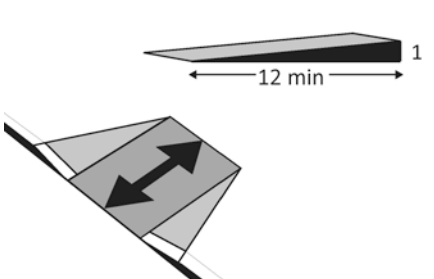
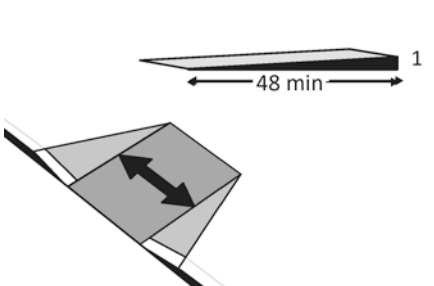
<p>1.18 Is the cross slope no steeper than 1:48? [403.3]</p>	<p><input type="checkbox"/> Yes <input type="checkbox"/> No</p> <p>Measurement:</p>		<p>Photo #:</p>	<ul style="list-style-type: none"> • Regrade to 1:48 max. • •
<p>Curb Ramps</p>				
<p>1.19 If the accessible route crosses a curb, is there a curb ramp? [402.2]</p>	<p><input type="checkbox"/> Yes <input type="checkbox"/> No</p>		<p>Photo #:</p>	<ul style="list-style-type: none"> • Install curb ramp • •
<p>1.20 Is the running slope of the curb ramp no steeper than 1:12, i.e. for every inch of height change there are at least 12 inches of curb ramp run? [406.1, 405.2]</p>	<p><input type="checkbox"/> Yes <input type="checkbox"/> No</p> <p>Measurement:</p>		<p>Photo #:</p>	<ul style="list-style-type: none"> • Regrade curb ramp • •
<p>1.21 Is the cross slope of the curb ramp, excluding flares, no steeper than 1:48? [406.1, 405.3]</p>	<p><input type="checkbox"/> Yes <input type="checkbox"/> No</p> <p>Measurement:</p>		<p>Photo #:</p>	<ul style="list-style-type: none"> • Regrade curb ramp • •

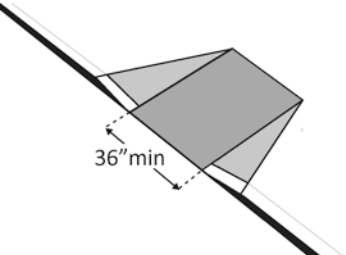
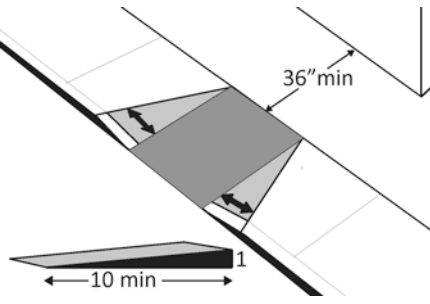
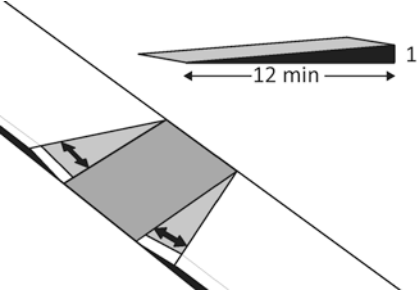

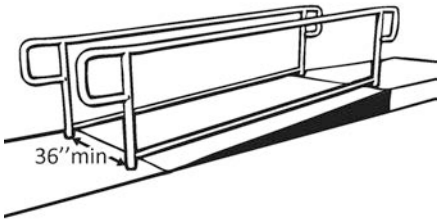
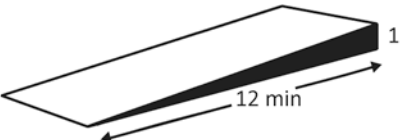
<p>1.22 Is the curb ramp, excluding flares, at least 36 inches wide? [406.1, 405.5]</p>	<p><input type="checkbox"/> Yes <input type="checkbox"/> No</p> <p>Measurement:</p>		<p>Photo #:</p>	<ul style="list-style-type: none"> • Widen curb ramp • •
<p>1.23 At the top of the curb ramp is there a level landing (slope no steeper than 1:48 in all directions) that is at least 36 inches long and at least as wide as the curb ramp? [406.4]</p> <p>If there are curb ramp flares, are the slopes of the flares no steeper than 1:10, i.e. for every inch of height change there are at least 10 inches of flare run? [406.3]</p>	<p><input type="checkbox"/> Yes <input type="checkbox"/> No</p> <p>Measurement:</p> <p><input type="checkbox"/> Yes <input type="checkbox"/> No</p> <p>Measurement:</p>		<p>Photo #:</p>	<ul style="list-style-type: none"> • Reconfigure • Add ramp flares •
<p>1.24 If the landing at the top is less than 36 inches long, are there curb ramp flares?</p> <p>Are the slopes of the flares no greater than 1:12, i.e. for every inch of height change there are at least 12 inches of flare run? [406.4]</p>	<p><input type="checkbox"/> Yes <input type="checkbox"/> No</p> <p><input type="checkbox"/> Yes <input type="checkbox"/> No</p> <p>Measurement:</p>		<p>Photo #:</p>	<ul style="list-style-type: none"> • Add ramp flares • Regrade flares •

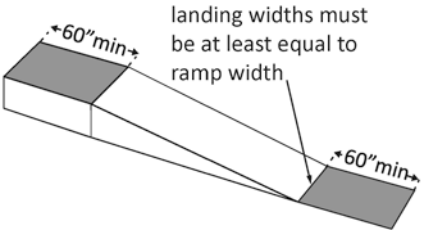
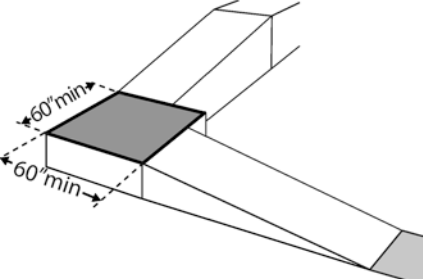
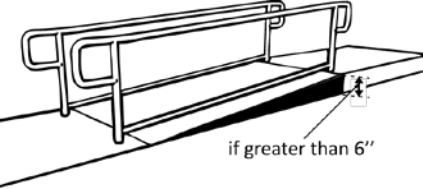
Ramps If any portion of the accessible route is steeper than 1:20, it should be treated as a ramp.				
<p>1.25 If there is a ramp is it at least 36 inches wide? [405.5]</p> <p>Note: If there are handrails, measure between the handrails.</p>	<p><input type="checkbox"/> Yes <input type="checkbox"/> No</p> <p>Measurement:</p>		<p>Photo #:</p>	<ul style="list-style-type: none"> • Alter ramp • •
<p>1.26 Is the surface stable, firm and slip resistant? [405.4]</p>	<p><input type="checkbox"/> Yes <input type="checkbox"/> No</p>		<p>Photo #:</p>	<ul style="list-style-type: none"> • Resurface ramp • •
<p>1.27 For each section of the ramp, is the running slope no greater than 1:12, i.e. for every inch of height change there are at least 12 inches of ramp run? [405.2]</p> <p>Note: Rises no greater than 3 inches with a slope no steeper than 1:8 and rises no greater than 6 inches with a slope no steeper than 1:10 are permitted when such slopes are necessary due to space limitations.</p>	<p><input type="checkbox"/> Yes <input type="checkbox"/> No</p> <p>Measurement:</p>		<p>Photo #:</p>	<ul style="list-style-type: none"> • Relocate ramp • Lengthen ramp to decrease slope •

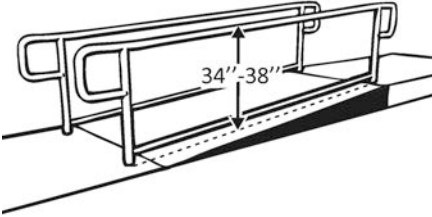
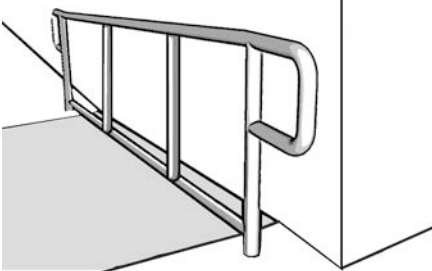
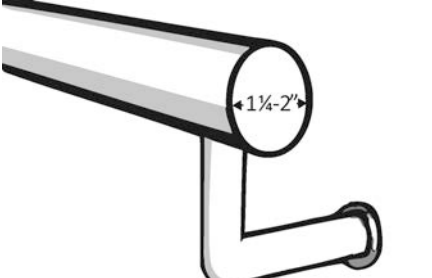
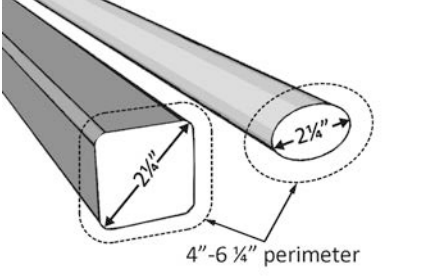
<p>1.28 Is there a level landing that is at least 60 inches long and at least as wide as the ramp:</p> <p>At the top of the ramp?</p> <p><input type="checkbox"/> Yes <input type="checkbox"/> No</p> <p>Measurement:</p> <p>At the bottom of the ramp? [405.7.2, 405.7.3]</p> <p><input type="checkbox"/> Yes <input type="checkbox"/> No</p> <p>Measurement:</p>	<p><input type="checkbox"/> Yes <input type="checkbox"/> No</p> <p>Measurement:</p> <p><input type="checkbox"/> Yes <input type="checkbox"/> No</p> <p>Measurement:</p>		<p>Photo #:</p>	<ul style="list-style-type: none"> • Alter ramp • Relocate ramp •
<p>1.29 Is there a level landing where the ramp changes direction that is at least 60 x 60 inches? [405.7.4]</p>	<p><input type="checkbox"/> Yes <input type="checkbox"/> No</p> <p>Measurement:</p>		<p>Photo #:</p>	<ul style="list-style-type: none"> • Alter ramp • Increase landing size •
<p>1.30 If the ramp has a rise higher than 6 inches, are there handrails on both sides? [405.8]</p> <p>Note: Curb ramps are not required to have handrails.</p>	<p><input type="checkbox"/> Yes <input type="checkbox"/> No</p> <p>Measurement:</p>		<p>Photo #:</p>	<ul style="list-style-type: none"> • Add handrails • •

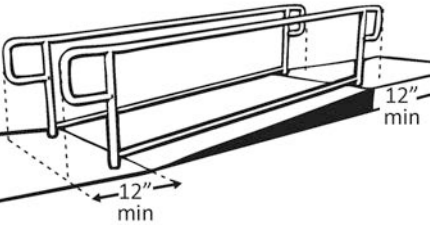
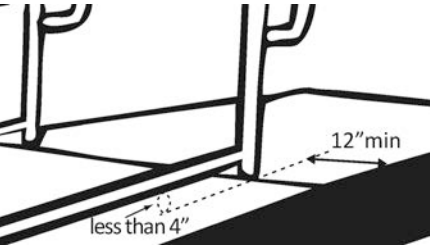
<p>1.31 Is the top of the handrail gripping surface no less than 34 inches and no greater than 38 inches above the ramp surface? [505.4]</p>	<p><input type="checkbox"/> Yes <input type="checkbox"/> No</p> <p>Measurement:</p>		<p>Photo #:</p>	<ul style="list-style-type: none"> • Reconfigure or replace handrails • Adjust handrail height •
<p>1.32 Is the handrail gripping surface continuous and not obstructed along the top or sides? [505.3]</p> <p>If there are obstructions, is the bottom of the gripping surface obstructed no greater than 20%? [505.6]</p>	<p><input type="checkbox"/> Yes <input type="checkbox"/> No</p> <p>Measurement:</p>		<p>Photo #:</p>	<ul style="list-style-type: none"> • Reconfigure or replace handrails • •
<p>1.33 If the handrail gripping surface is circular, is it no less than 1 1/4 inches and no greater than 2 inches in diameter? [505.7.1]</p>	<p><input type="checkbox"/> Yes <input type="checkbox"/> No</p> <p>Measurement:</p>		<p>Photo #:</p>	<ul style="list-style-type: none"> • Replace handrails • •
<p>1.34 If the handrail gripping surface is non-circular:</p> <p>Is the perimeter no less than 4 inches and no greater than 6 1/4 inches?</p>	<p><input type="checkbox"/> Yes <input type="checkbox"/> No</p> <p>Measurement:</p>		<p>Photo #:</p>	<ul style="list-style-type: none"> • Replace handrails • •

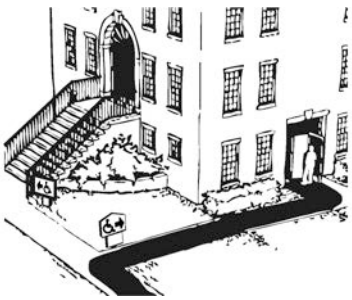

<p>Is the cross section no greater than 2¼ inches? [505.7.2]</p>			<p>Photo #:</p>	
<p>1.35 Does the handrail:</p> <p>Extend at least 12 inches horizontally beyond the top and bottom of the ramp?</p> <p>Return to a wall, guard, or landing surface? [505.10.1]</p> <p>Note: If a 12 inch extension would be a hazard (in circulation path) it is not required.</p>	<p><input type="checkbox"/> Yes <input type="checkbox"/> No</p> <p>Measurement:</p> <p><input type="checkbox"/> Yes <input type="checkbox"/> No</p>		<p>Photo #:</p>	<ul style="list-style-type: none"> • Alter handrails • •
<p>1.36 To prevent wheelchair casters and crutch tips from falling off:</p> <p>Does the surface of the ramp extend at least 12 inches beyond the inside face of the handrail? Or Is there a curb or barrier that prevents the passage of a 4-inch diameter sphere? [405.9.1, 405.9.2]</p>	<p><input type="checkbox"/> Yes <input type="checkbox"/> No</p> <p>Measurement:</p> <p><input type="checkbox"/> Yes <input type="checkbox"/> No</p> <p>Measurement:</p>		<p>Photo #:</p>	<ul style="list-style-type: none"> • Add curb • Add barrier • Extend ramp width •

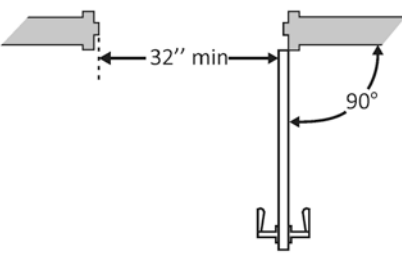
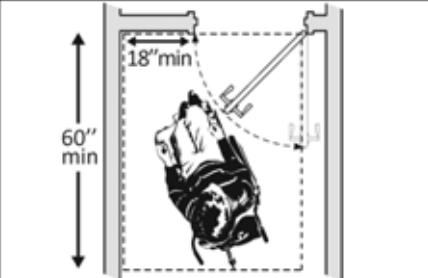
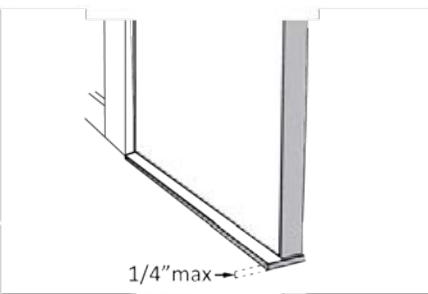
Entrance				
<p>1.37 Is the main entrance accessible?</p>	<p><input type="checkbox"/> Yes <input type="checkbox"/> No</p>		<p>Photo #:</p>	<ul style="list-style-type: none"> • Redesign to make it accessible • •
<p>1.38 If the main entrance is not accessible, is there an alternative accessible entrance?</p> <p>Can the alternative accessible entrance be used independently and during the same hours as the main entrance?</p>	<p><input type="checkbox"/> Yes <input type="checkbox"/> No</p> <p><input type="checkbox"/> Yes <input type="checkbox"/> No</p>		<p>Photo #:</p>	<ul style="list-style-type: none"> • Designate an entrance and make it accessible • Ensure that accessible entrance can be used independently and during the same hours as the main entrance •
<p>1.39 Do all inaccessible entrances have signs indicating the location of the nearest accessible entrance? [216.6]</p>	<p><input type="checkbox"/> Yes <input type="checkbox"/> No</p>		<p>Photo #:</p>	<ul style="list-style-type: none"> • Install signs • Install signs on route before people get to inaccessible entrances so that people do not have to turn around and retrace route •
<p>1.40 If not all entrances are accessible, is there a sign at the accessible entrance with the International Symbol of Accessibility? [216.6]</p>	<p><input type="checkbox"/> Yes <input type="checkbox"/> No</p>		<p>Photo #:</p>	<ul style="list-style-type: none"> • Install sign • •

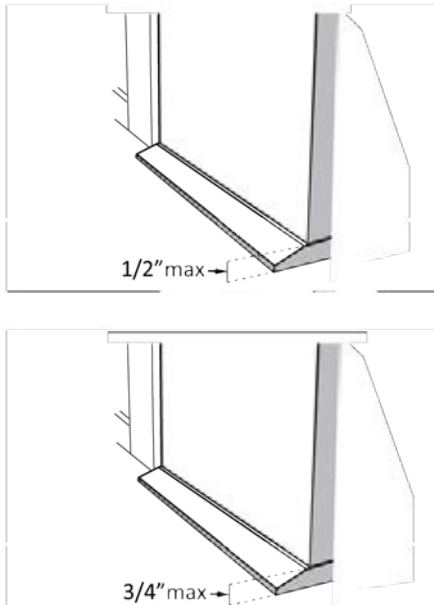
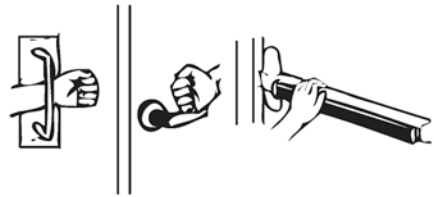
<p>1.41 Is the clear opening width of the accessible entrance door at least 32 inches, between the face of the door and the stop, when the door is open 90 degrees? [404.2.3]</p>	<p><input type="checkbox"/> Yes <input type="checkbox"/> No Measurement:</p>		<p>Photo #:</p>	<ul style="list-style-type: none"> • Alter door • Install offset hinges •
<p>1.42 If there is a front approach to the pull side of the door, is there at least 18 inches of maneuvering clearance beyond the latch side plus at least 60 inches clear depth? Note: See 2010 Standards 404.2.4 for maneuvering clearance requirements on the push side of the door and side approaches to the pull side of the door</p> <p>On both sides of the door, is the ground or floor surface of the maneuvering clearance level (no steeper than 1:48)? [404.2.4]</p>	<p><input type="checkbox"/> Yes <input type="checkbox"/> No Measurement:</p> <p><input type="checkbox"/> Yes <input type="checkbox"/> No Measurement:</p>		<p>Photo #:</p>	<ul style="list-style-type: none"> • Remove obstructions • Reconfigure walls • Add automatic door opener
<p>1.43 If the threshold is vertical is it no more than ¼ inch high? Or No more than ½ inch high with the top ¼ inch beveled no steeper than 1:2, if the threshold was installed on or</p>	<p><input type="checkbox"/> Yes <input type="checkbox"/> No Measurement:</p> <p><input type="checkbox"/> Yes <input type="checkbox"/> No Measurement:</p>		<p>Photo #:</p>	<ul style="list-style-type: none"> • Remove or replace threshold • •

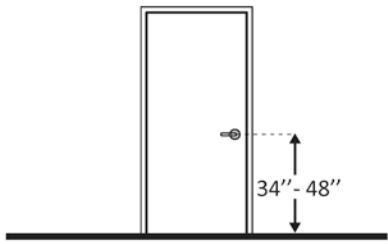
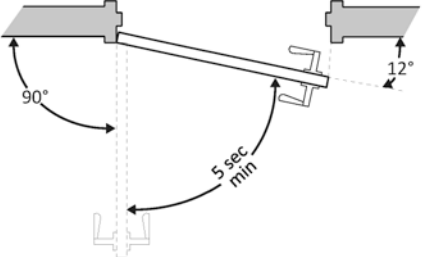
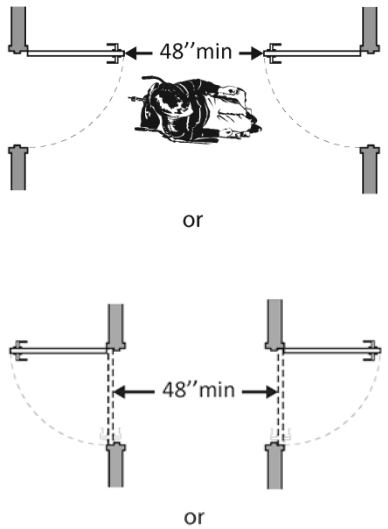
<p>after the 1991 ADA Standards went into effect (1/26/93)?</p> <p>Or</p> <p>No more than $\frac{3}{4}$ inch high with the top $\frac{1}{2}$ inch beveled no steeper than 1:2, if the threshold was installed before the 1991 ADA Standards went into effect (1/26/93)? [404.2.5, 303.2]</p> <p>Note: The first $\frac{1}{4}$ inch of the $\frac{1}{2}$ or $\frac{3}{4}$ inch threshold may be vertical; the rest must be beveled.</p>	<p><input type="checkbox"/> Yes <input type="checkbox"/> No</p> <p>Measurement:</p>		<p>Photo #:</p>	
<p>1.44 Is the door equipped with hardware that is operable with one hand and does not require tight grasping, pinching or twisting of the wrist?</p> <p>Door handle?</p> <p>Lock (if provided)? [404.2.7]</p>	<p><input type="checkbox"/> Yes <input type="checkbox"/> No</p>		<p>Photo #:</p>	<ul style="list-style-type: none"> • Replace inaccessible knob with lever, loop or push hardware • Add automatic door opener •

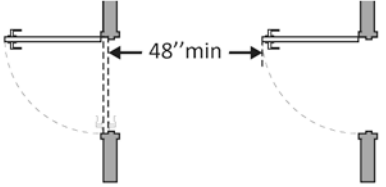
<p>1.45 Are the operable parts of the door hardware no less than 34 inches and no greater than 48 inches above the floor or ground surface? [404.2.7]</p>	<p><input type="checkbox"/> Yes <input type="checkbox"/> No</p> <p>Measurement:</p>		<p>Photo #:</p>	<ul style="list-style-type: none"> • Change hardware height • •
<p>1.46 If the door has a closer, does it take at least 5 seconds to close from an open position of 90 degrees to a position of 12 degrees from the latch? [404.2.8]</p>	<p><input type="checkbox"/> Yes <input type="checkbox"/> No</p> <p>Measurement:</p>		<p>Photo #:</p>	<ul style="list-style-type: none"> • Adjust closer • •
<p>1.47 If there are two doors in a series, e.g. vestibule, is the distance between the doors at least 48 inches plus the width of the doors when swinging into the space? [404.2.6]</p>	<p><input type="checkbox"/> Yes <input type="checkbox"/> No</p> <p>Measurement:</p>		<p>Photo #:</p>	<ul style="list-style-type: none"> • Remove inner door • Change door swing •

			<p>Photo #:</p>	
<p>1.48 If provided at the building entrance, are carpets or mats no higher than ½ inch thick? [302.2]</p>	<p><input type="checkbox"/> Yes <input type="checkbox"/> No</p> <p>Measurement:</p>		<p>Photo #:</p>	<ul style="list-style-type: none"> • Replace or remove mats • •
<p>1.49 Are edges of carpets or mats securely attached to minimize tripping hazards? [302.2]</p>	<p><input type="checkbox"/> Yes <input type="checkbox"/> No</p>		<p>Photo #:</p>	<ul style="list-style-type: none"> • Secure carpeting or mats at edges • •
	<p><input type="checkbox"/> Yes <input type="checkbox"/> No</p>		<p>Photo #:</p>	<ul style="list-style-type: none"> • • •
	<p><input type="checkbox"/> Yes <input type="checkbox"/> No</p>		<p>Photo #:</p>	<ul style="list-style-type: none"> • • •

ADA Checklist for Existing Facilities

Priority 2 – Access to Goods & Services

Based on the 2010 ADA Standards for Accessible Design

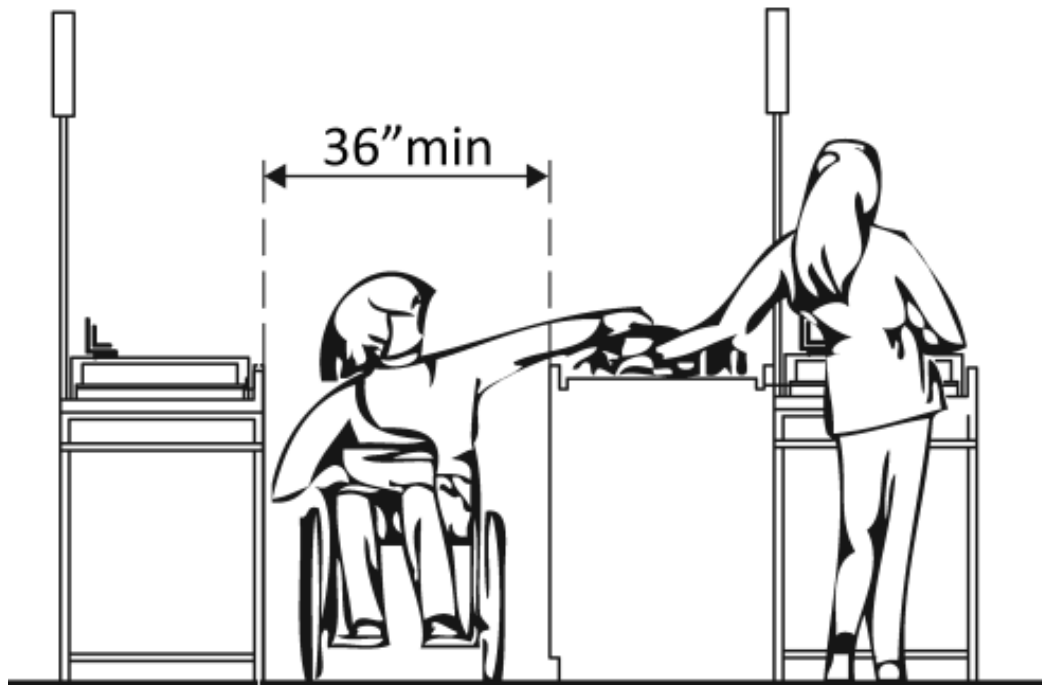

Project _____

Building _____

Location _____

Date _____

Surveyors _____

Contact Information _____

The layout of the building should allow people with disabilities to obtain goods and services and to participate in activities without assistance.



Institute for Human Centered Design
www.HumanCenteredDesign.org

Copyright © 2016



ADA National Network
Questions on the ADA 800-949-4232 voice/tty
www.ADAchecklist.org



This checklist was produced by the New England ADA Center, a project of the Institute for Human Centered Design and a member of the ADA National Network. This checklist was developed under a grant from the Department of Education, NIDRR grant number H133A060092-09A. However the contents do not necessarily represent the policy of the Department of Education, and you should not assume endorsement by the Federal Government.

Questions or comments on the checklist contact the New England ADA Center at 617-695-0085 voice/tty or ADAinfo@NewEnglandADA.org

For the full set of checklists, including the checklists for recreation facilities visit www.ADAchecklist.org.

Copyright © 2016 ADA Checklist for Existing Materials. You can freely reproduce and distribute this content. Include proper attribution. But you must get permission before using this content as a fee-based product.

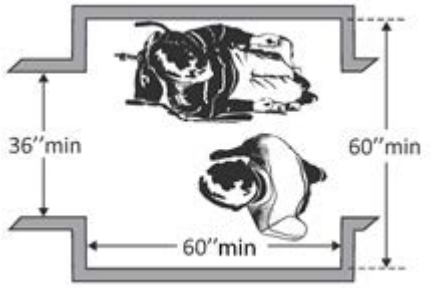
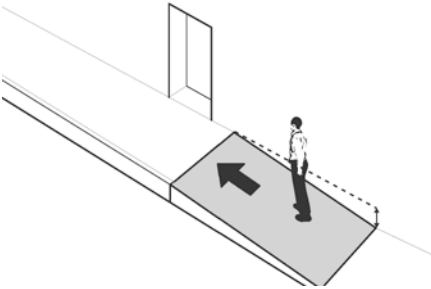
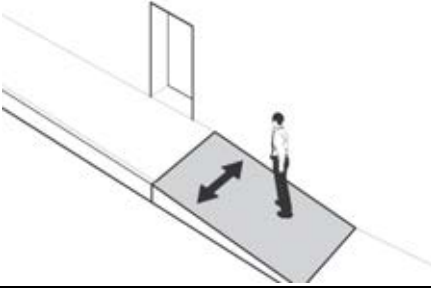
Priority 2 – Access to Goods & Services		Comments	Possible Solutions
<p>2.1 Does the accessible entrance provide direct access to the main floor, lobby and elevator? [See 2010 ADA Standards for Accessible Design – 206.4]</p>	<input type="checkbox"/> Yes <input type="checkbox"/> No	<p>Photo #:</p>	<ul style="list-style-type: none"> • Create accessible route • •
<p>Interior Accessible Route</p>			
<p>2.2 Are all public spaces on at least one accessible route? [206.2.4]</p>	<input type="checkbox"/> Yes <input type="checkbox"/> No	<p>Photo #:</p>	<ul style="list-style-type: none"> • Create accessible route • •
<p>2.3 Is the route stable, firm and slip-resistant? [40.2, 302.1]</p>	<input type="checkbox"/> Yes <input type="checkbox"/> No	<p>Photo #:</p>	<ul style="list-style-type: none"> • Repair uneven surfaces • •
<p>2.4 Is the route at least 36 inches wide? [403.5.1]</p> <p>Note: The accessible route can narrow to 32 inches min. for a max. of 24 inches. These narrower portions of the route must be at least 48 inches from each other.</p>	<input type="checkbox"/> Yes <input type="checkbox"/> No Measurement:	<p>36" min</p> <p>24" max 48" min 24" max</p> <p>32" min 32" min</p>	<p>Photo #:</p> <ul style="list-style-type: none"> • Widen route • •

<p>2.5 If the route is greater than 200 feet in length and less than 60 inches wide, is there a passing space no less than 60 x 60 inches? [403.5.3]</p>	<p><input type="checkbox"/> Yes <input type="checkbox"/> No Measurement:</p>		<p>Photo #:</p>	<ul style="list-style-type: none"> • Widen route for passing space • •
<p>2.6 Is the running slope no steeper than 1:20, i.e. for every inch of height change there are at least 20 inches of route run? [403.3]</p> <p>Note: If the running slope is steeper than 1:20, treat as a ramp and add features such as edge protection and handrails.</p>	<p><input type="checkbox"/> Yes <input type="checkbox"/> No Measurement:</p>		<p>Photo #:</p>	<ul style="list-style-type: none"> • Regrade • •
<p>2.7 Is the cross slope no steeper than 1:48? [403.3]</p>	<p><input type="checkbox"/> Yes <input type="checkbox"/> No Measurement:</p>		<p>Photo #:</p>	<ul style="list-style-type: none"> • Regrade • •
<p>2.8 Do all objects on circulation paths through public areas, e.g. fire extinguishers, drinking fountains, signs, etc., protrude no more than 4 inches into the path? Or</p>	<p><input type="checkbox"/> Yes <input type="checkbox"/> No Measurement:</p>	 <p>Or</p>	<p>Photo #:</p>	<ul style="list-style-type: none"> • Remove object • Add tactile warning such as permanent planter or partial walls •

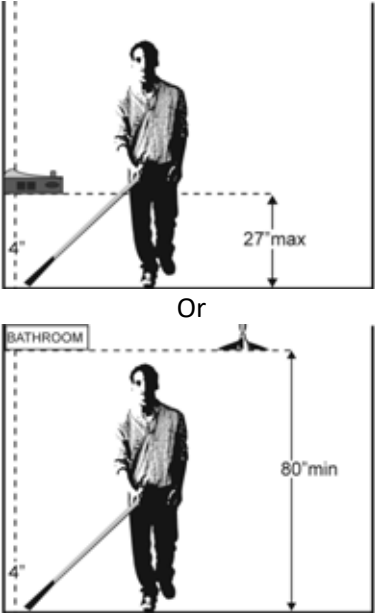
<p>If an object protrudes more than 4 inches, is the bottom leading edge at 27 inches or lower above the floor? [307.2]</p> <p>Or</p> <p>Is the bottom leading edge at 80 inches or higher above the floor? [307.4]</p>	<p><input type="checkbox"/> Yes <input type="checkbox"/> No</p> <p>Measurement:</p> <p><input type="checkbox"/> Yes <input type="checkbox"/> No</p> <p>Measurement:</p>	 <p>Or</p>	<p>Photo #:</p>	
<p>2.9 Are there elevators or platform lifts to all public stories?</p> <p>Note: Vertical access is not required in new construction or alterations if a facility is less than three stories or has less than 3,000 square feet per story, unless the facility is a shopping center, shopping mall, professional office of a health care provider, transportation terminal, state facility or local government facility</p>	<p><input type="checkbox"/> Yes <input type="checkbox"/> No</p>		<p>Photo #:</p>	<ul style="list-style-type: none"> • Install if necessary • Offer goods and services on an accessible story •

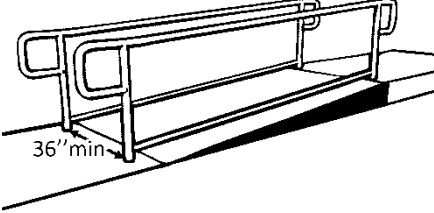
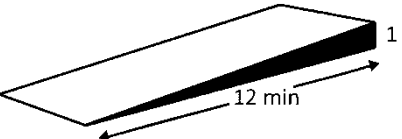
Ramps				
<p>2.10 If there is a ramp, is it at least 36 inches wide? [405.5]</p> <p>Note: If there are handrails, measure between the handrails.</p>	<p><input type="checkbox"/> Yes <input type="checkbox"/> No</p> <p>Measurement:</p>		<p>Photo #:</p>	<ul style="list-style-type: none"> • Alter ramp • •
<p>2.11 Is the surface stable, firm and slip resistant? [405.4]</p>	<p><input type="checkbox"/> Yes <input type="checkbox"/> No</p>		<p>Photo #:</p>	<ul style="list-style-type: none"> • Resurface ramp • •
<p>2.12 For each section of the ramp, is the running slope no greater than 1:12, i.e. for every inch of height change there are at least 12 inches of ramp run? [405.2]</p> <p>Note: Rises no greater than 3 inches with a slope no steeper than 1:8 and rises no greater than 6 inches with a slope no steeper than 1:10 are permitted when due to space limitations.</p>	<p><input type="checkbox"/> Yes <input type="checkbox"/> No</p> <p>Measurement:</p>		<p>Photo #:</p>	<ul style="list-style-type: none"> • Lengthen ramp to decrease slope • Relocate ramp •

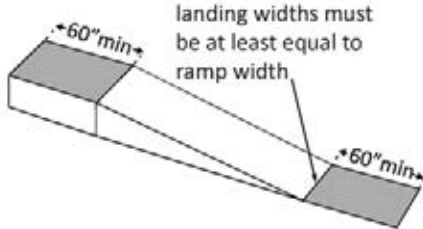
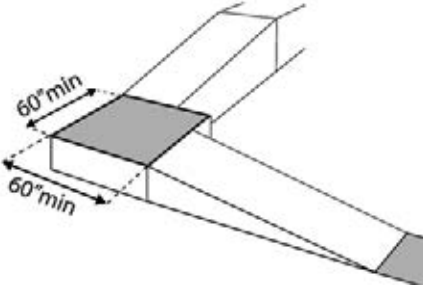
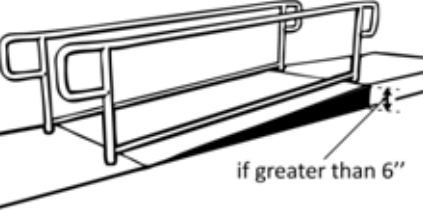

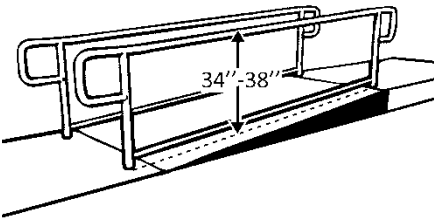
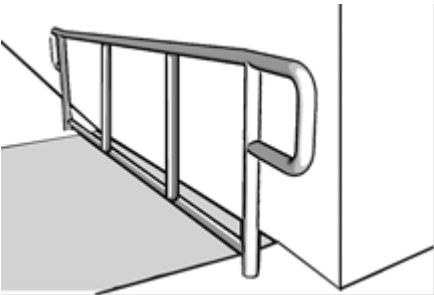
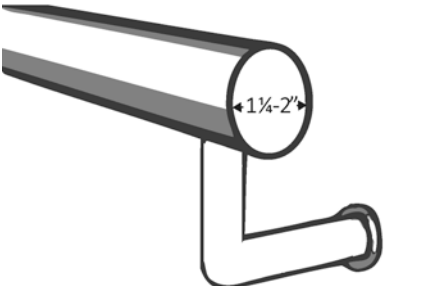
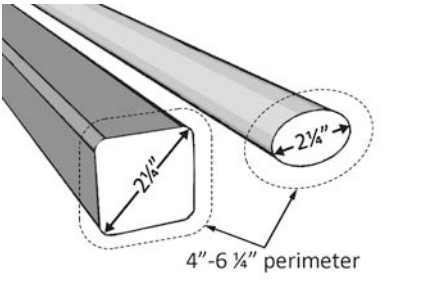
<p>2.13 Is there a level landing that is at least 60 inches long and at least as wide as the ramp:</p> <p>At the top of the ramp?</p> <p>At the bottom of the ramp? [405.7.2, 405.7.3]</p>	<p><input type="checkbox"/> Yes <input type="checkbox"/> No</p> <p>Measurement:</p> <p><input type="checkbox"/> Yes <input type="checkbox"/> No</p> <p>Measurement:</p>		<p>Photo #:</p>	<ul style="list-style-type: none"> • Alter ramp • Relocate ramp •
<p>2.14 Is there a level landing where the ramp changes direction that is at least 60 x 60 inches? [405.7.4]</p>	<p><input type="checkbox"/> Yes <input type="checkbox"/> No</p> <p>Measurement:</p>		<p>Photo #:</p>	<ul style="list-style-type: none"> • Increase landing size • •
<p>2.15 If the ramp has a rise higher than 6 inches are there handrails on both sides? [405.8]</p>	<p><input type="checkbox"/> Yes <input type="checkbox"/> No</p> <p>Measurement:</p>		<p>Photo #:</p>	<ul style="list-style-type: none"> • Add handrails • •

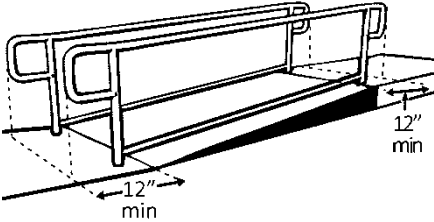
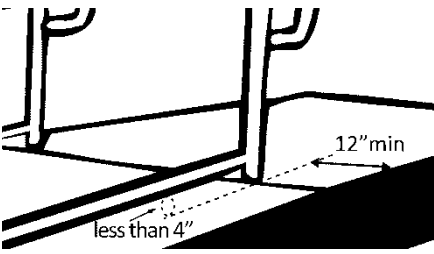
<p>2.16 Is the top of the handrail gripping surface no less than 34 inches and no greater than 38 inches above the ramp surface? [505.4]</p>	<p><input type="checkbox"/> Yes <input type="checkbox"/> No</p> <p>Measurement:</p>		<p>Photo #:</p>	<ul style="list-style-type: none"> • Adjust handrail height • •
<p>2.17 Is the handrail gripping surface continuous and not obstructed along the top or sides? [505.3]</p> <p>If there are obstructions, is the bottom of the gripping surface obstructed no more than 20%? [505.6]</p>	<p><input type="checkbox"/> Yes <input type="checkbox"/> No</p> <p><input type="checkbox"/> Yes <input type="checkbox"/> No</p> <p>Measurement:</p>		<p>Photo #:</p>	<ul style="list-style-type: none"> • Reconfigure or replace handrails • •
<p>2.18 If the handrail gripping surface is circular, is it no less than 1 ¼ inches and no greater than 2 inches in diameter? [505.7.1]</p>	<p><input type="checkbox"/> Yes <input type="checkbox"/> No</p> <p>Measurement:</p>		<p>Photo #:</p>	<ul style="list-style-type: none"> • Replace handrails • •
<p>2.19 If the handrail gripping surface is non-circular:</p> <p>Is the perimeter no less than 4 inches and no greater than 6 ¼ inches?</p>	<p><input type="checkbox"/> Yes <input type="checkbox"/> No</p> <p>Measurement:</p>		<p>Photo #:</p>	<ul style="list-style-type: none"> • Replace handrails • •

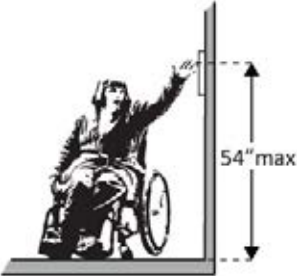
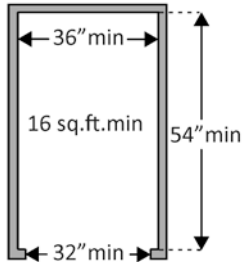
<p>Is the cross section no greater than 2¼ inches? [505.7.2]</p>	<p><input type="checkbox"/> Yes <input type="checkbox"/> No Measurement:</p>		<p>Photo #:</p>	
<p>2.20 Does the handrail:</p> <p>Extend at least 12 inches horizontally beyond the top and bottom of the ramp?</p> <p>Return to a wall, guard, or landing surface? [505.10.1]</p> <p>Note: If a 12" extension would be hazardous (in circulation path), it is not required.</p>	<p><input type="checkbox"/> Yes <input type="checkbox"/> No Measurement:</p> <p><input type="checkbox"/> Yes <input type="checkbox"/> No Measurement:</p>		<p>Photo #:</p>	<ul style="list-style-type: none"> • Alter handrails • •
<p>2.21 To prevent wheelchair casters and crutch tips from falling off:</p> <p>Does the surface of the ramp extend at least 12 inches beyond the inside face of the handrail? Or Is there a curb or barrier that prevents the passage of a 4-inch diameter sphere? [405.9.1, 405.9.2]</p>	<p><input type="checkbox"/> Yes <input type="checkbox"/> No Measurement:</p> <p><input type="checkbox"/> Yes <input type="checkbox"/> No Measurement:</p>		<p>Photo #:</p>	<ul style="list-style-type: none"> • Add curb • Add barrier • Extend ramp width • •

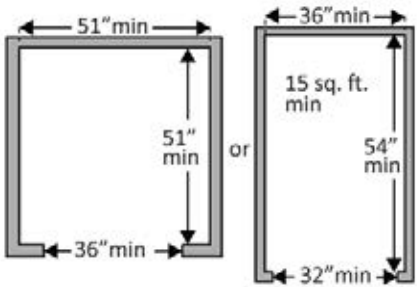
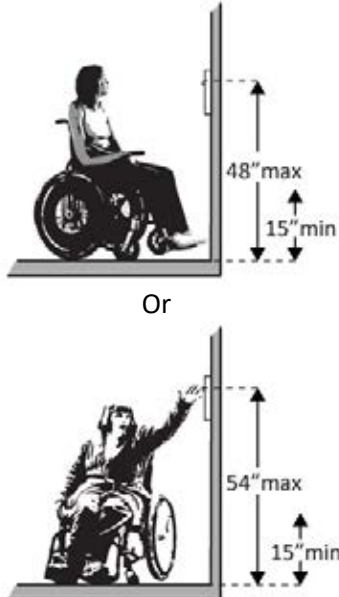
Elevators – Full Size & LULA (limited use, limited application) LULA elevators are often used in alterations.				
<p>2.22 If there is a full size or LULA elevator, are the call buttons no higher than 54 inches above the floor? [407.2.1.1]</p>	<p><input type="checkbox"/> Yes <input type="checkbox"/> No Measurement:</p>		<p>Photo #:</p>	<ul style="list-style-type: none"> • Change call button height • •
<p>2.23 If there is a full size or LULA elevator, does the sliding door reopen automatically when obstructed by an object or person?*</p>	<p><input type="checkbox"/> Yes <input type="checkbox"/> No</p>		<p>Photo #:</p>	<p>* If constructed before 3/15/2012 and manually operated, the door is not required to reopen automatically</p> <ul style="list-style-type: none"> • Install opener •
<p>2.24 If there is a LULA elevator with a swinging door:</p> <p>Is the door power-operated?</p> <p>Does the door remain open for at least 20 seconds when activated?</p>	<p><input type="checkbox"/> Yes <input type="checkbox"/> No <input type="checkbox"/> Yes <input type="checkbox"/> No Time:</p>		<p>Photo #:</p>	<ul style="list-style-type: none"> • Add power operated door • Adjust opening time •
<p>2.25 If there is a full size elevator:</p> <p>Is the interior at least 54 inches deep by at least 36 inches wide with at least 16 sq. ft. of clear floor area?</p> <p>Is the door opening width at</p>	<p><input type="checkbox"/> Yes <input type="checkbox"/> No Measurement: <input type="checkbox"/> Yes <input type="checkbox"/> No</p>		<p>Photo #:</p>	<ul style="list-style-type: none"> • Replace elevator • •

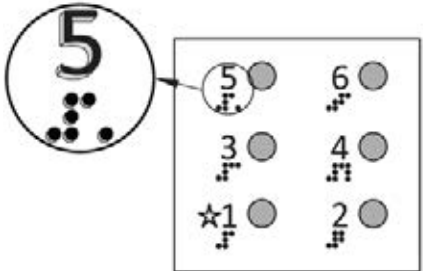
<p>least 32 inches? [407.4.1 Exception]</p>	<p>Measurement:</p>		<p>Photo #:</p>	
<p>2.26 If there is a LULA elevator, is the interior:</p> <p>At least 51 inches deep by 51 inches wide with a door opening width of at least 36 inches? Or At least 54 inches deep by at least 36 inches wide with at least 15 sq. ft. of clear floor area and a door opening width of at least 32 inches? [408.4.1 Exceptions 1 and 2]</p>	<p><input type="checkbox"/> Yes <input type="checkbox"/> No Measurement:</p> <p><input type="checkbox"/> Yes <input type="checkbox"/> No Measurement:</p>		<p>Photo #:</p>	<ul style="list-style-type: none"> • Replace elevator • •
<p>2.27 If there is a full size or LULA elevator, are the in-car controls:</p> <p>No less than 15 inches and no greater 48 inches above the floor? Or Up to 54 inches above the floor for a parallel approach? [408.4.6, 407.4.6.1]</p>	<p><input type="checkbox"/> Yes <input type="checkbox"/> No Measurement:</p> <p><input type="checkbox"/> Yes <input type="checkbox"/> No Measurement:</p>		<p>Photo #:</p>	<ul style="list-style-type: none"> • Change control height • •

<p>2.28 If there is a LULA elevator, are the in-car controls centered on a side wall? [408.4.6]</p>	<p><input type="checkbox"/> Yes <input type="checkbox"/> No</p> <p>Measurement:</p>		<p>Photo #:</p>	<ul style="list-style-type: none"> • Reconfigure controls • •
<p>2.29 If there is a full size or LULA elevator:</p> <p>Are the car control buttons designated with raised characters?</p> <p>Are the car control buttons designated with Braille? [407.4.7.1, 703.2]</p>	<p><input type="checkbox"/> Yes <input type="checkbox"/> No</p> <p><input type="checkbox"/> Yes <input type="checkbox"/> No</p>		<p>Photo #:</p>	<ul style="list-style-type: none"> • Add raised characters • Add Braille •
<p>2.30 If there is a full size elevator, are there audible signals which sound as the car passes or is about to stop at a floor? [407.4.8]</p>	<p><input type="checkbox"/> Yes <input type="checkbox"/> No</p>		<p>Photo #:</p>	<ul style="list-style-type: none"> • Install audible signals • •
<p>2.31 If there is a full size or LULA elevator:</p> <p>Is there a sign on both door jambs at every floor identifying the floor?</p> <p>Is there a tactile star on both jambs at the main entry level?</p> <p>Do text characters contrast</p>	<p><input type="checkbox"/> Yes <input type="checkbox"/> No</p> <p><input type="checkbox"/> Yes <input type="checkbox"/> No</p> <p><input type="checkbox"/> Yes <input type="checkbox"/> No</p>		<p>Photo #:</p>	<ul style="list-style-type: none"> • Install signs • Change sign height • •

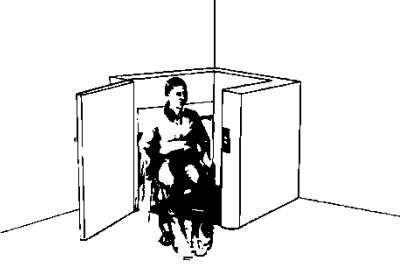
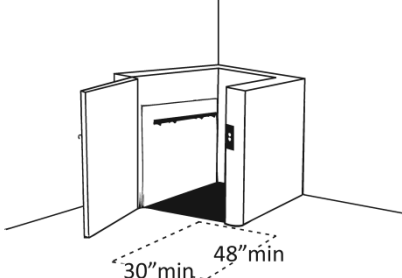
<p>with their backgrounds?</p> <p>Are text characters raised?</p> <p>Is there Braille?</p> <p>Is the sign mounted between 48 inches to the baseline of the lowest character and 60 inches to the baseline of the highest character above the floor?*</p> <p>[407.2.3, 408.2.3]</p>	<p><input type="checkbox"/> Yes <input type="checkbox"/> No</p> <p><input type="checkbox"/> Yes <input type="checkbox"/> No</p> <p><input type="checkbox"/> Yes <input type="checkbox"/> No</p> <p>Measurement:</p>		<p>Photo #:</p>	<p>* If constructed before 3/15/2012 and mounted no higher than 60 inches to the centerline of the sign, relocation is not required</p>
<p>Platform Lifts</p>				
<p>2.32 If a lift is provided, can it be used without assistance from others?</p> <p>[410.1]</p>	<p><input type="checkbox"/> Yes <input type="checkbox"/> No</p>		<p>Photo #:</p>	<ul style="list-style-type: none"> • Reconfigure so independently operable • •
<p>2.33 Is there a clear floor space at least 30 inches wide by at least 48 inches long for a person using a wheelchair to approach and reach the controls to use the lift?</p> <p>[410.5]</p>	<p><input type="checkbox"/> Yes <input type="checkbox"/> No</p> <p>Measurement:</p>		<p>Photo #:</p>	<ul style="list-style-type: none"> • Remove obstructions • •

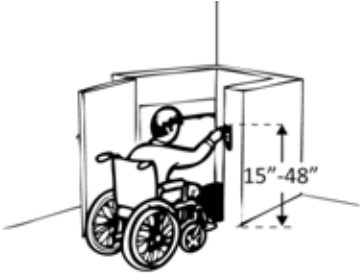
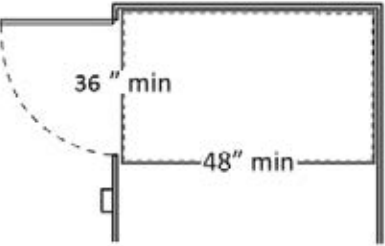
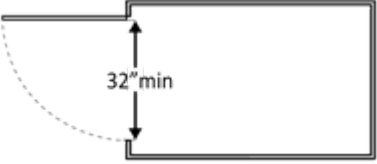
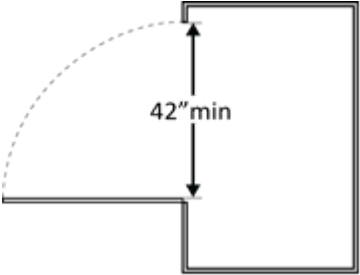
<p>2.34 Are the lift controls no less than 15 inches and no greater than 48 inches above the floor? [410.5]</p>	<p><input type="checkbox"/> Yes <input type="checkbox"/> No</p> <p>Measurement:</p>		<p>Photo #:</p>	<ul style="list-style-type: none"> • Change control height • •
<p>2.35 Is there a clear floor space at least 36 inches wide by at least 48 inches long inside the lift? [410.3]</p>	<p><input type="checkbox"/> Yes <input type="checkbox"/> No</p> <p>Measurement:</p>		<p>Photo #:</p>	<ul style="list-style-type: none"> • Replace lift • •
<p>2.36 If there is an end door, is the clear opening width at least 32 inches? [410.6]</p>	<p><input type="checkbox"/> Yes <input type="checkbox"/> No</p> <p>Measurement:</p>		<p>Photo #:</p>	<ul style="list-style-type: none"> • Alter door width • •
<p>2.37 If there is a side door, is the clear opening width at least 42 inches? [410.6]</p>	<p><input type="checkbox"/> Yes <input type="checkbox"/> No</p> <p>Measurement:</p>		<p>Photo #:</p>	<ul style="list-style-type: none"> • Alter door width • •

Signs “Tactile characters” are read using touch, i.e. raised characters and Braille.

2.38 If there are signs designating permanent rooms and spaces not likely to change over time, e.g. room numbers and letters, room names, and exit signs: [216.2]

Do text characters contrast with their backgrounds? [703.5]

Are text characters raised? [703.2]

Is there Braille? [703.3]

Is the sign mounted: On the wall on the latch side of the door? [703.4.2]

Note: Signs are permitted on the push side of doors with closers and without hold-open devices.

With clear floor space beyond the arc of the door swing and 45-degree open position, at least 18 x 18 inches centered on the tactile characters?*[703.4.2]

Yes No

Yes No

Yes No

Yes No

Yes No

Measurement:

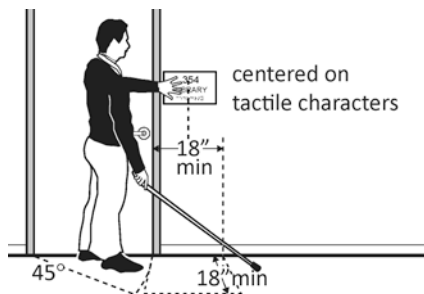
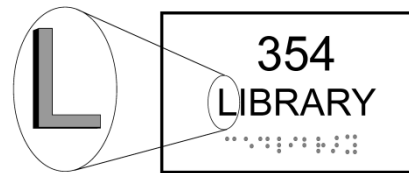

- Install tactile sign
- Relocate sign
-

*If constructed before 3/15/2012 and a person may approach within 3 inches of the sign without encountering protruding objects or standing within the door swing, relocation not required

So the baseline of the lowest character is at least 48 inches above the floor and the baseline of the highest character is no more than 60 inches above the floor? * [703.4.1]

Note: If the sign is at double doors with one active leaf, the sign should be on the inactive leaf; if both leaves are active, the sign should be on the wall to the right of the right leaf.

Yes No

Measurement:

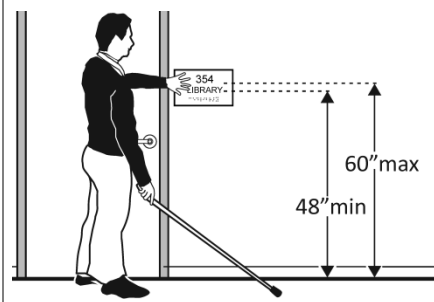

Photo #:

*If constructed before 3/15/2012 and mounted no higher than 60 inches to the centerline of the sign, relocation not required

2.39 If there are signs that provide direction to or information about interior spaces:

Do text characters contrast with their backgrounds? [703.5.1]

Is the sign mounted so that characters are at least 40 inches above the floor? [703.5.6]

Note: Raised characters and Braille are not required.

Yes No

Yes No

Measurement:

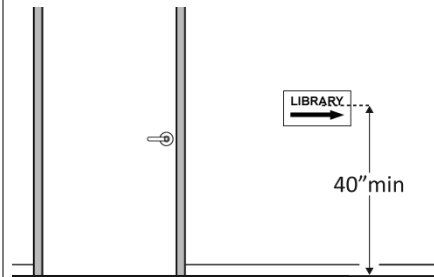
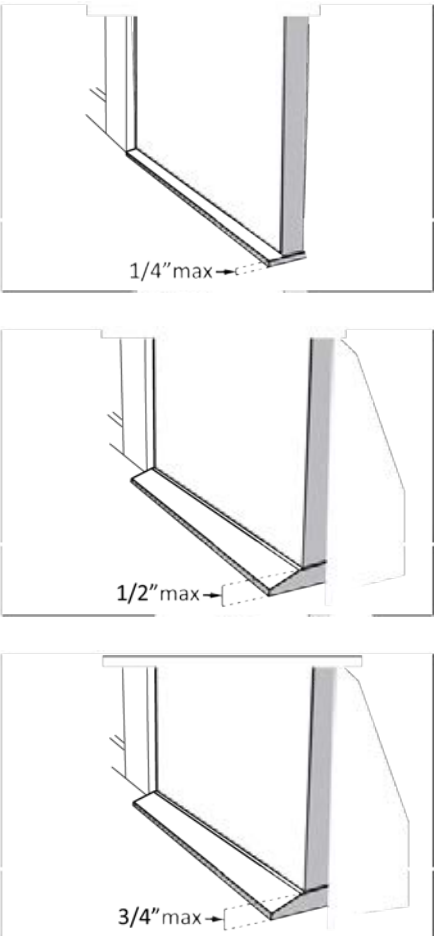

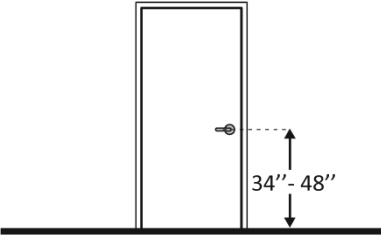
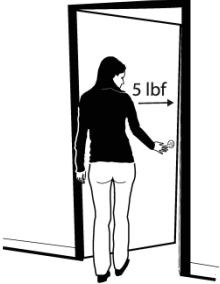
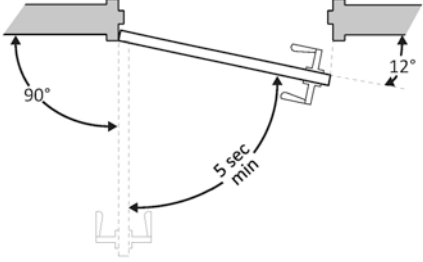
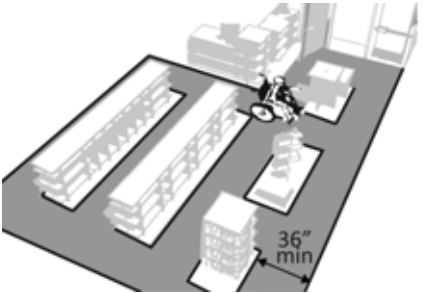

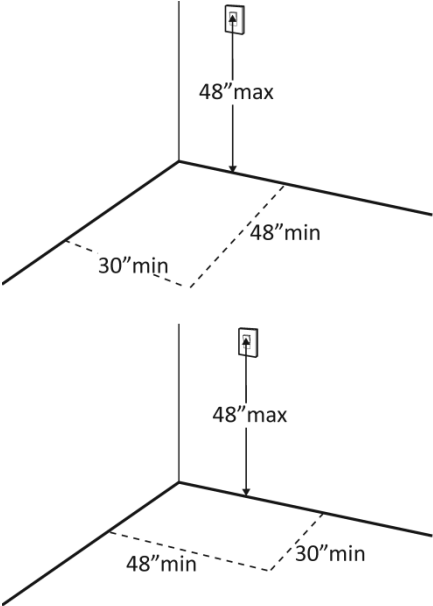

Photo #:

- Install signs with contrasting characters
- Change sign height
-

<p>2.42 If the threshold is vertical is it no more than ¼ inch high?</p> <p>Or</p> <p>No more than ½ inch high with the top ¼ inch beveled no steeper than 1:2, if the threshold was installed on or after the 1991 ADA Standards went into effect (1/26/93)?</p> <p>Or</p> <p>No more than ¾ inch high with the top ½ inch beveled no steeper than 1:2, if the threshold was installed before the 1991 ADA Standards went into effect (1/26/93)? [404.2.5, 303.2]</p> <p>Note: The first ¼ inch of the ½ or ¾ inch threshold may be vertical; the rest must be beveled.</p>	<p><input type="checkbox"/> Yes <input type="checkbox"/> No Measurement:</p> <p><input type="checkbox"/> Yes <input type="checkbox"/> No Measurement:</p> <p><input type="checkbox"/> Yes <input type="checkbox"/> No Measurement:</p>		<p>Photo #:</p>	<ul style="list-style-type: none"> • Remove or replace threshold • •
<p>2.43 Is the door equipped with hardware that is operable with one hand and does not require tight grasping, pinching or twisting of the wrist?</p> <p>Door handle?</p> <p>Lock (if provided)? [404.2.7]</p>	<p><input type="checkbox"/> Yes <input type="checkbox"/> No</p> <p><input type="checkbox"/> Yes <input type="checkbox"/> No</p> <p><input type="checkbox"/> Yes <input type="checkbox"/> No</p>		<p>Photo #:</p>	<ul style="list-style-type: none"> • Replace inaccessible knob with lever, loop or push hardware • Add automatic door opener •

<p>2.44 Are the operable parts of the hardware no less than 34 inches and no greater than 48 inches above the floor? [404.2.7]</p>	<p><input type="checkbox"/> Yes <input type="checkbox"/> No Measurement:</p>		<p>Photo #:</p>	<ul style="list-style-type: none"> • Change hardware height • •
<p>2.45 Can the door be opened easily (5 pounds maximum force)? [404.2.9]</p> <p>Note: You can use a pressure gauge or fish scale to measure force. If you do not have one you will need to judge whether the door is easy to open.</p>	<p><input type="checkbox"/> Yes <input type="checkbox"/> No Measurement:</p>		<p>Photo #:</p>	<ul style="list-style-type: none"> • Adjust or replace closers • Install lighter doors • Install power-assisted or automatic door openers
<p>2.46 If the door has a closer, does it take at least 5 seconds to close from an open position of 90 degrees to a position of 12 degrees from the latch? [404.2.8.1]</p>	<p><input type="checkbox"/> Yes <input type="checkbox"/> No Measurement:</p>		<p>Photo #:</p>	<ul style="list-style-type: none"> • Adjust closer • •
<p>Rooms and Spaces – stores, supermarkets, libraries, etc.</p>				
<p>2.47 Are aisles and pathways to goods and services, and to one of each type of sales and service counters, at least 36 inches wide? [403.5.1]</p>	<p><input type="checkbox"/> Yes <input type="checkbox"/> No Measurement:</p>		<p>Photo #:</p>	<ul style="list-style-type: none"> • Rearrange goods, equipment and furniture • •

<p>2.48 Are floor surfaces stable, firm and slip resistant? [302.1]</p>	<p><input type="checkbox"/> Yes <input type="checkbox"/> No</p>		<p>Photo #:</p>	<ul style="list-style-type: none"> • Change floor surface • •
<p>2.49 If there is carpet: Is it no higher than ½ inch? Is it securely attached along the edges? [302.2]</p>	<p><input type="checkbox"/> Yes <input type="checkbox"/> No Measurement: <input type="checkbox"/> Yes <input type="checkbox"/> No Measurement:</p>		<p>Photo #: 5</p>	<ul style="list-style-type: none"> • Replace carpet • •
<p>Controls – light switches, security and intercom systems, emergency/alarm boxes, etc.</p>				
<p>2.50 Is there a clear floor space at least 30 inches wide by at least 48 inches long for a forward or parallel approach? [305.3] Are the operable parts no higher than 48 inches above the floor?* [309.3, 308]</p>	<p><input type="checkbox"/> Yes <input type="checkbox"/> No Measurement: <input type="checkbox"/> Yes <input type="checkbox"/> No Measurement:</p>		<p>Photo #:</p>	<ul style="list-style-type: none"> • Change height of control • • <p>*If constructed before 3/15/2012 and a parallel approach is provided, controls can be 54 inches above the floor</p>

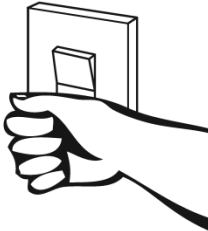

<p>2.51 Can the control be operated with one hand and without tight grasping, pinching, or twisting of the wrist? [309.4]</p>	<p><input type="checkbox"/> Yes <input type="checkbox"/> No</p>		<p>Photo #:</p>	<ul style="list-style-type: none"> • Replace control • •
------------------------------------------------------------------------------------------------------------------------------------------	-----------------------------------------------------------------	------------------------------------------------------------------------------------	-----------------	-------------------------------------------------------------------------------------------

Seating: Assembly Areas – theaters, auditoriums, stadiums, theater style classrooms, etc.

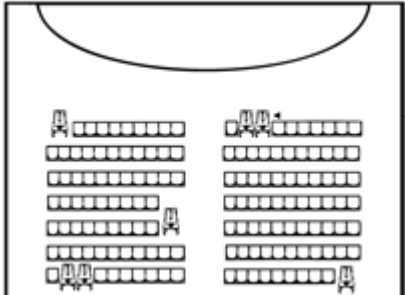

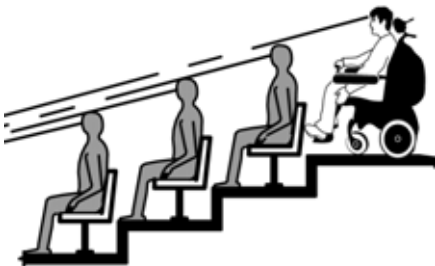
<p>2.52 Are an adequate number of wheelchair spaces provided? [221.2.1]</p>	<p><input type="checkbox"/> Yes <input type="checkbox"/> No</p> <p>Total #:</p> <p>Wheelchair #:</p>	<table border="1"> <thead> <tr> <th># of Seats</th> <th>Wheelchair Spaces</th> </tr> </thead> <tbody> <tr> <td>4 - 25</td> <td>1</td> </tr> <tr> <td>26 - 50</td> <td>2</td> </tr> <tr> <td>51 - 150</td> <td>4</td> </tr> <tr> <td>151 - 300</td> <td>5</td> </tr> <tr> <td colspan="2">300+ see 2010 Standards 221.2.1.</td> </tr> </tbody> </table>	# of Seats	Wheelchair Spaces	4 - 25	1	26 - 50	2	51 - 150	4	151 - 300	5	300+ see 2010 Standards 221.2.1.		<p>Photo #:</p>	<ul style="list-style-type: none"> • Reconfigure to add wheelchair spaces • •
# of Seats	Wheelchair Spaces															
4 - 25	1															
26 - 50	2															
51 - 150	4															
151 - 300	5															
300+ see 2010 Standards 221.2.1.																

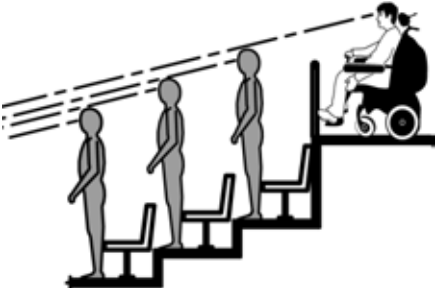
<p>2.53 Are wheelchair spaces dispersed to allow location choices and viewing angles equivalent to other seating, including specialty seating areas that provide distinct services and amenities? [221.2.3]</p>	<p><input type="checkbox"/> Yes <input type="checkbox"/> No</p>		<p>Photo #:</p>	<ul style="list-style-type: none"> • Reconfigure to disperse wheelchair spaces • •
----------------------------------------------------------------------------------------------------------------------------------------------------------------------------------------------------------------------------	-----------------------------------------------------------------	-------------------------------------------------------------------------------------	-----------------	---------------------------------------------------------------------------------------------------------------------

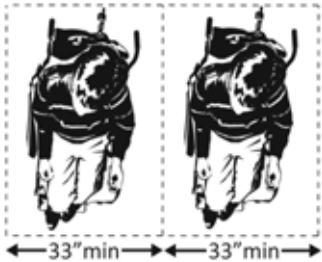
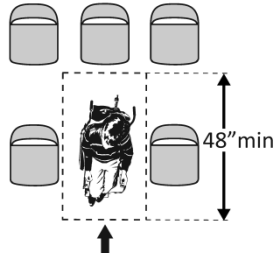
<p>2.54 Where people are expected to remain seated, do people in wheelchair spaces have a clear line of sight over and between the heads of others in front of them? [802.2.1.1, 802.1.1.2]</p>	<p><input type="checkbox"/> Yes <input type="checkbox"/> No</p>		<p>Photo #:</p>	<ul style="list-style-type: none"> • Alter for line of sight • •
------------------------------------------------------------------------------------------------------------------------------------------------------------------------------------------------------------	-----------------------------------------------------------------	--------------------------------------------------------------------------------------	-----------------	---------------------------------------------------------------------------------------------------

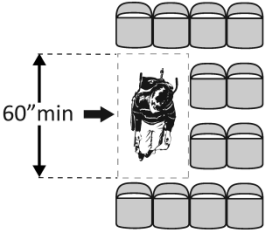
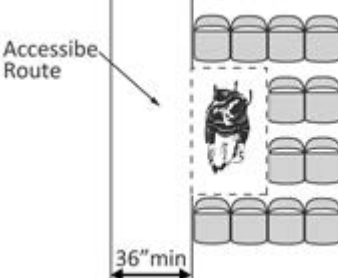
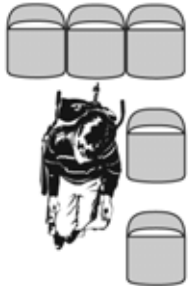
<p>2.55 Where people are expected to stand, do people in wheelchair spaces have a clear line of sight over and between the heads of others in front of them? [802.2.2.1, 802.1.2.2]</p>	<p><input type="checkbox"/> Yes <input type="checkbox"/> No</p>		<p>Photo #:</p>	<ul style="list-style-type: none"> • Alter for line of sight • •
<p>2.56 If there is a single wheelchair space, is it at least 36 inches wide? [802.1.2]</p>	<p><input type="checkbox"/> Yes <input type="checkbox"/> No Measurement:</p>		<p>Photo #:</p>	<ul style="list-style-type: none"> • Alter space • •
<p>2.57 If there are two adjacent wheelchair spaces, are they each at least 33 inches wide? [802.1.2]</p>	<p><input type="checkbox"/> Yes <input type="checkbox"/> No Measurement:</p>		<p>Photo #:</p>	<ul style="list-style-type: none"> • Alter spaces • •
<p>2.58 If the wheelchair space can be entered from the front or rear, is it at least 48 inches deep? [802.1.3]</p>	<p><input type="checkbox"/> Yes <input type="checkbox"/> No Measurement:</p>		<p>Photo #:</p>	<ul style="list-style-type: none"> • Alter space • •

<p>2.59 If the wheelchair space can only be entered from the side, is it at least 60 inches deep? [802.1.3]</p>	<p><input type="checkbox"/> Yes <input type="checkbox"/> No</p> <p>Measurement:</p>		<p>Photo #:</p>	<ul style="list-style-type: none"> • Alter space • •
<p>2.60 Do wheelchair spaces adjoin, but not overlap, accessible routes? [802.1.4]</p>	<p><input type="checkbox"/> Yes <input type="checkbox"/> No</p>		<p>Photo #:</p>	<ul style="list-style-type: none"> • Alter spaces • •
<p>2.61 Is there at least one companion seat for each wheelchair space? [221.3]</p>	<p><input type="checkbox"/> Yes <input type="checkbox"/> No</p>		<p>Photo #:</p>	<ul style="list-style-type: none"> • Add companion seats • •
<p>2.62 Is the companion seat located so the companion is shoulder-to-shoulder with the person in a wheelchair? [802.3.1]</p>	<p><input type="checkbox"/> Yes <input type="checkbox"/> No</p>		<p>Photo #:</p>	<ul style="list-style-type: none"> • Alter seating • •
<p>2.63 Is the companion seat equivalent in size, quality, comfort and amenities to seating in the immediate area? [802.3.2]</p>	<p><input type="checkbox"/> Yes <input type="checkbox"/> No</p>		<p>Photo #:</p>	<ul style="list-style-type: none"> • Add equivalent seating • •

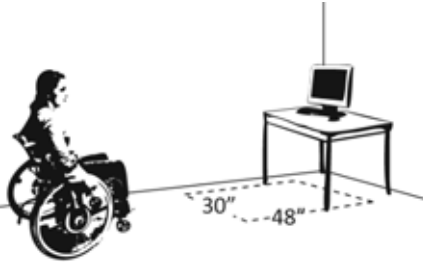
Seating: At dining surfaces (restaurants, cafeterias, bars, etc.) and non-employee work surfaces (libraries, conference rooms, etc.)				
<p>2.64 Are at least 5%, but no fewer than one, of seating and standing spaces accessible for people who use wheelchairs? [226.1]</p>	<p><input type="checkbox"/> Yes <input type="checkbox"/> No</p> <p>Total #:</p> <p>Wheelchair #:</p>		<p>Photo #:</p>	<ul style="list-style-type: none"> • Alter to provide accessible spaces • •
<p>2.65 Is there a route at least 36 inches wide to accessible seating? [403.5.1]</p>	<p><input type="checkbox"/> Yes <input type="checkbox"/> No</p> <p>Measurement:</p>		<p>Photo #:</p>	<ul style="list-style-type: none"> • Widen route • •
<p>2.66 At the accessible space(s), is the top of the accessible surface no less than 28 inches and no greater than 34 inches above the floor? [902.3]</p> <p>Note: If for children, the top should be no less than 26 inches and no greater than 30 inches above the floor.</p>	<p><input type="checkbox"/> Yes <input type="checkbox"/> No</p> <p>Measurement:</p>		<p>Photo #:</p>	<ul style="list-style-type: none"> • Alter surface height • •
<p>2.67 Is there a clear floor space at least 30 inches wide by at least 48 inches long for a forward approach? [305.3]</p> <p>Does it extend no less than 17 inches and no greater than 25 inches under the surface?</p>	<p><input type="checkbox"/> Yes <input type="checkbox"/> No</p> <p>Measurement:</p> <p><input type="checkbox"/> Yes <input type="checkbox"/> No</p> <p>Measurement:</p>		<p>Photo #:</p>	<ul style="list-style-type: none"> • Alter table or work surface • Add accessible table or work surface •

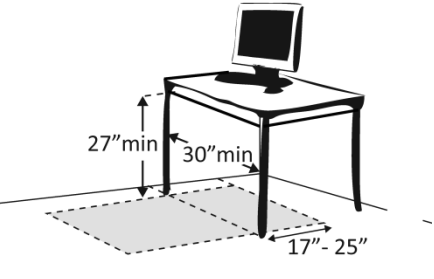
<p>Is there knee space at least 27 inches high and at least 30 inches wide? [306.2, 306.3]</p> <p>Note: If for children, the knee space may be 24 inches high.</p>	<p><input type="checkbox"/> Yes <input type="checkbox"/> No Measurement:</p>		<p>Photo #:</p>	
------------------------------------------------------------------------------------------------------------------------------------------------------------------------	----------------------------------------------------------------------------------	------------------------------------------------------------------------------------	-----------------	--

Seating: General – reception areas, waiting rooms, etc.

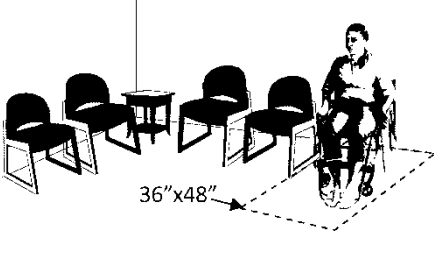
<p>2.68 Is there at least one space at least 36 inches wide by at least 48 inches long for a person in a wheelchair? [802.1.2, 802.1.3]</p>	<p><input type="checkbox"/> Yes <input type="checkbox"/> No Measurement:</p>		<p>Photo #:</p>	<ul style="list-style-type: none"> • Move furniture and equipment to provide space • •
--------------------------------------------------------------------------------------------------------------------------------------------------------	----------------------------------------------------------------------------------	------------------------------------------------------------------------------------	-----------------	-------------------------------------------------------------------------------------------------------------------------

Benches – In locker rooms, dressing rooms, fitting rooms This section does not apply to any other benches.

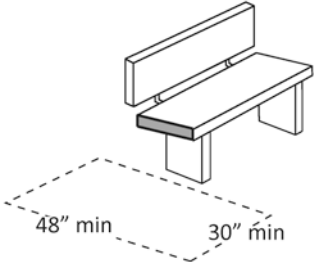
<p>2.69 In locker rooms, dressing rooms and fitting rooms, is there at least one room with a bench? [222.1, 803.4]</p>	<p><input type="checkbox"/> Yes <input type="checkbox"/> No</p>		<p>Photo #:</p>	<ul style="list-style-type: none"> • Add bench • •
<p>2.70 Is there a clear floor space at least 30 inches wide by at least 48 inches long at the end of the bench and parallel to the short axis of the bench?</p> <p>Is the bench seat at least 42 inches long and no less than 20 inches and no greater than 24 inches deep?</p>	<p><input type="checkbox"/> Yes <input type="checkbox"/> No Measurement:</p> <p><input type="checkbox"/> Yes <input type="checkbox"/> No Measurement:</p>			<ul style="list-style-type: none"> • Move bench • Replace bench • Affix bench to wall • •

Does the bench have back support or is it affixed to a wall?

Yes No

Is the top of the bench seat no less than 17 inches and no greater than 19 inches above the floor?
[903]

Yes No

Measurement:

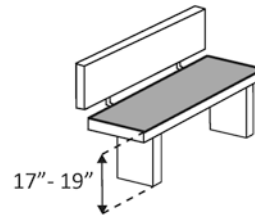
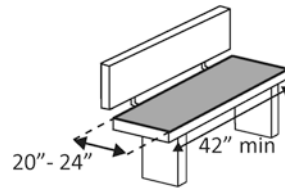

Photo #:

Check-Out Aisles – supermarkets, large retail stores, etc.

2.71 Is the aisle at least 36 inches wide?
[904.3.1]

Yes No

Measurement:

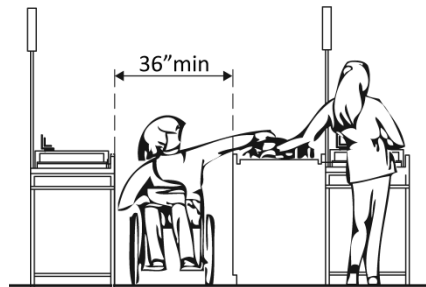

Photo #:

- Widen aisle
-
-

2.72 Is the counter surface of at least one aisle no higher than 38 inches above the floor?
[904.3.2]

Yes No

Measurement:

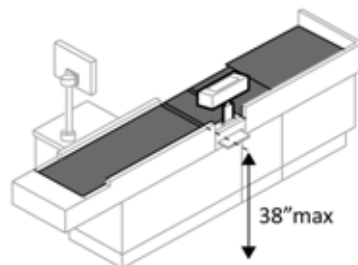
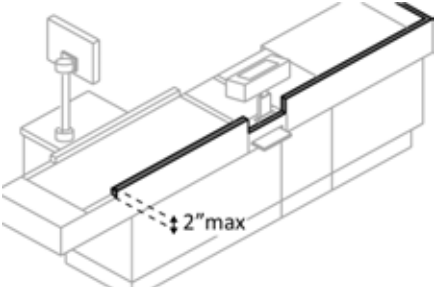
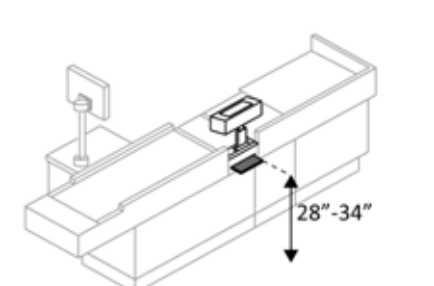

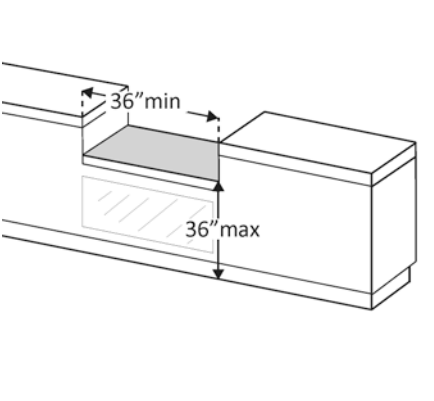
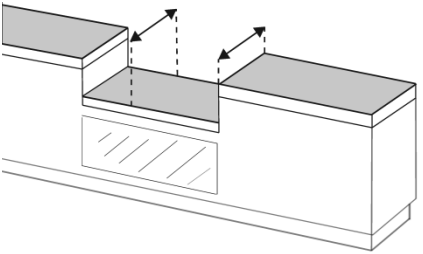
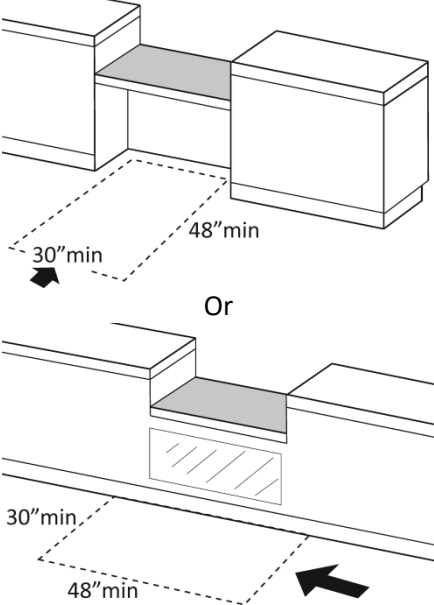
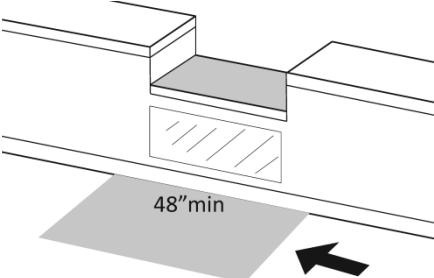
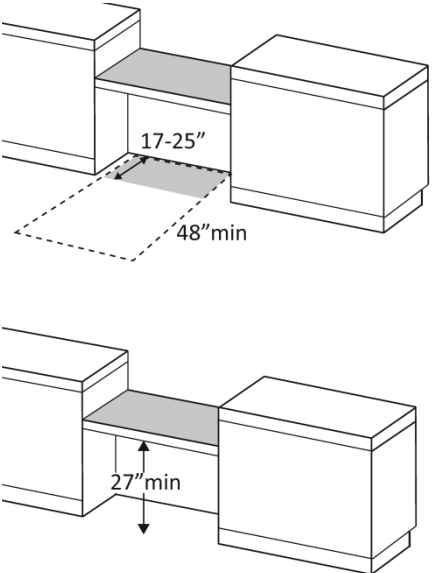

Photo #:

- Lower counter
- Signage to surface counter at larg classroom
-

<p>2.73 Is the top of the counter edge protection no higher than 2 inches above the counter surface? [904.3.2]</p>	<p><input type="checkbox"/> Yes <input type="checkbox"/> No Measurement:</p>		<p>Photo #:</p>	<ul style="list-style-type: none"> • Lower edge protection • •
<p>2.74 If there is a check writing surface, is the top no less than 28 inches and no greater than 34 inches above the floor? [904.3.3]</p>	<p><input type="checkbox"/> Yes <input type="checkbox"/> No Measurement:</p>		<p>Photo #:</p>	<ul style="list-style-type: none"> • Alter check writing surface • Lower counter at large classroom •
<p>2.75 If there is more than one check-out aisle is there a sign with the International Symbol of Accessibility at the accessible aisle? [216.11]</p>	<p><input type="checkbox"/> Yes <input type="checkbox"/> No</p>		<p>Photo #:</p>	<ul style="list-style-type: none"> • Add sign • •
<p>Sales & Service Counters – banks, stores, dry cleaners, auto repair shops, fitness clubs, etc.</p>				
<p>2.76 Is there a portion of at least one of each type of counter that is: No higher than 36 inches above the floor? At least 36 inches long? [904.4.1]</p>	<p><input type="checkbox"/> Yes <input type="checkbox"/> No Measurement:</p> <p><input type="checkbox"/> Yes <input type="checkbox"/> No Measurement:</p>		<p>Photo #:</p>	<ul style="list-style-type: none"> • Lower section of counter • Lengthen section of counter •

<p>2.77 Does the accessible portion of the counter extend the same depth as the counter top? [904.4]</p>	<p><input type="checkbox"/> Yes <input type="checkbox"/> No</p> <p>Measurement:</p>		<p>Photo #:</p>	<ul style="list-style-type: none"> • Alter accessible portion • •
<p>2.78 Is there a clear floor space at least 30 inches wide by at least 48 inches long for a forward or parallel approach? [904.4]</p>	<p><input type="checkbox"/> Yes <input type="checkbox"/> No</p> <p><input type="checkbox"/> Parallel</p> <p>Measurement:</p> <p><input type="checkbox"/> Forward</p> <p>Measurement:</p>		<p>Photo #:</p>	<ul style="list-style-type: none"> • Reconfigure to provide a parallel or forward approach • •
<p>2.79 For a parallel approach, is the clear floor space positioned with the 48 inches adjacent to the accessible length of counter? [904.4.1]</p>	<p><input type="checkbox"/> Yes <input type="checkbox"/> No</p> <p>Measurement:</p>		<p>Photo #:</p>	<ul style="list-style-type: none"> • If a parallel approach is not possible, a forward approach is required • •

<p>2.80 For a forward approach:</p> <p>Do no less than 17 and no greater than 25 inches of the clear floor space extend under the accessible length of the counter? [306.2.2, 306.2.3]</p> <p>Is there at least 27 inches clearance from the floor to the bottom of the counter? [306.3.1]</p>	<p><input type="checkbox"/> Yes <input type="checkbox"/> No</p> <p>Measurement:</p> <p><input type="checkbox"/> Yes <input type="checkbox"/> No</p> <p>Measurement:</p>		<p>Photo #:</p>	<ul style="list-style-type: none"> • Reconfigure to provide knee clearance • •
---------------------------------------------------------------------------------------------------------------------------------------------------------------------------------------------------------------------------------------------------------------------------------------------------------------	-------------------------------------------------------------------------------------------------------------------------------------------------------------------------	------------------------------------------------------------------------------------	-----------------	-----------------------------------------------------------------------------------------------------------------

Food Service Lines – in cafeterias, salad bars, eat-in fast food establishments, etc.

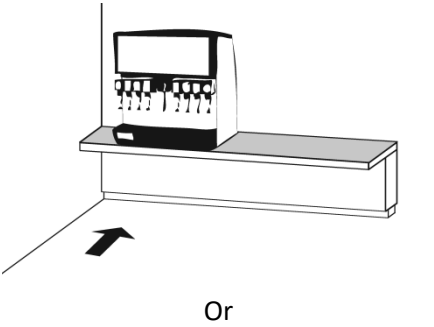
<p>2.81 Does at least one of each type of self-service shelf or dispensing device for tableware, dishware, condiments, food and beverages have a forward or parallel approach? [904.5.1]</p>	<p><input type="checkbox"/> Yes <input type="checkbox"/> No</p> <p><input type="checkbox"/> Forward</p> <p><input type="checkbox"/> Parallel</p>			<ul style="list-style-type: none"> • Reconfigure to provide approach • •
---------------------------------------------------------------------------------------------------------------------------------------------------------------------------------------------------------	--------------------------------------------------------------------------------------------------------------------------------------------------	-------------------------------------------------------------------------------------	--	-----------------------------------------------------------------------------------------------------------

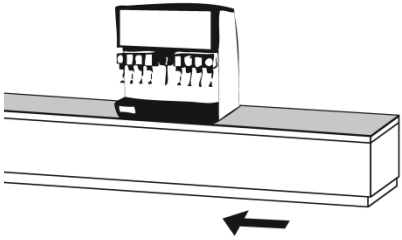
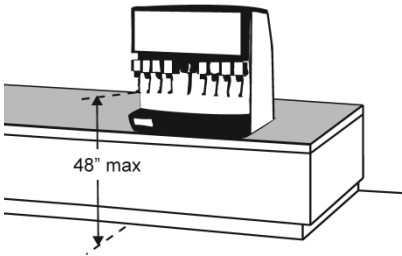
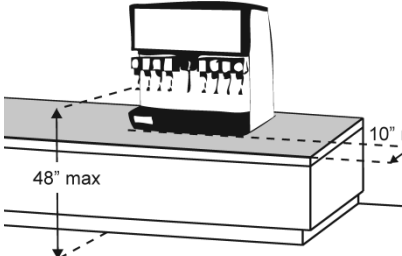
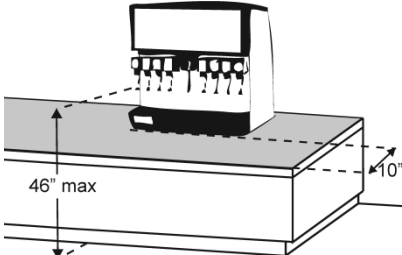
			<p>Photo #:</p>	
<p>2.82 If there is an unobstructed parallel approach, is the shelf or dispensing device no higher than 48 inches above the floor? [308.3.1]</p>	<p><input type="checkbox"/> Yes <input type="checkbox"/> No Measurement:</p>		<p>Photo #:</p>	<ul style="list-style-type: none"> • Lower shelf and/or dispensing device • •
<p>2.83 If there is a shallow obstruction no deeper than 10 inches with a parallel approach, is the shelf or dispensing device no higher than 48 inches above the floor? [308.3.1]</p>	<p><input type="checkbox"/> Yes <input type="checkbox"/> No Measurement:</p>		<p>Photo #:</p>	<ul style="list-style-type: none"> • Lower shelf and/or dispensing device • •
<p>2.84 If there is an obstruction no less than 10 inches and no greater than 24 inches deep with a parallel approach, is the shelf or dispensing device no higher than 46 inches above the floor? [308.3.2]</p>	<p><input type="checkbox"/> Yes <input type="checkbox"/> No Measurement:</p>		<p>Photo #:</p>	<ul style="list-style-type: none"> • Lower shelf and/or dispensing device • •

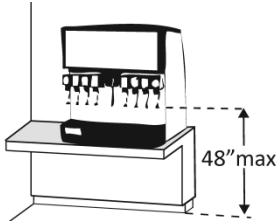
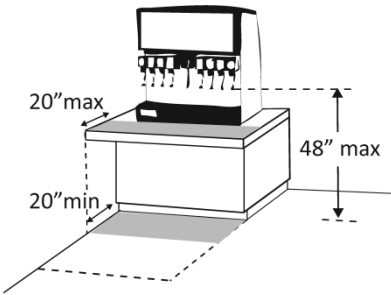
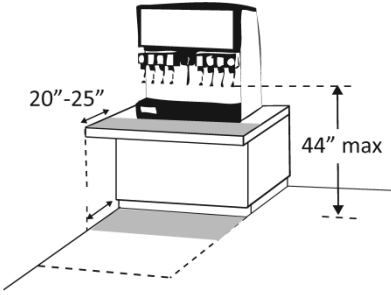
<p>2.85 If there is an unobstructed forward approach, is the shelf or dispensing device no higher than 48 inches above the floor? [308.2.1]</p>	<p><input type="checkbox"/> Yes <input type="checkbox"/> No</p> <p>Measurement:</p>		<p>Photo #:</p>	<ul style="list-style-type: none"> • Lower shelf and/or dispensing device • •
<p>2.86 If there is an obstruction no deeper than 20 inches with a forward approach:</p> <p>Does clear floor space extend under the obstruction that is at least the same depth as the obstruction?</p> <p>Is the shelf or dispensing device no higher than 48 inches above the floor? [904.5.1]</p>	<p><input type="checkbox"/> Yes <input type="checkbox"/> No</p> <p>Measurement:</p> <p><input type="checkbox"/> Yes <input type="checkbox"/> No</p> <p>Measurement:</p>		<p>Photo #:</p>	<ul style="list-style-type: none"> • Reconfigure to provide knee space • Lower shelf and/or dispensing device •
<p>2.87 If the obstruction is no less than 20 inches and no greater than 25 inches deep with a forward approach:</p> <p>Does clear floor space extend under the obstruction that is at least the same depth as the obstruction?</p> <p>Is the shelf or dispensing device no higher than 44 inches above the floor? [904.5.1]</p>	<p><input type="checkbox"/> Yes <input type="checkbox"/> No</p> <p>Measurement:</p> <p><input type="checkbox"/> Yes <input type="checkbox"/> No</p> <p>Measurement:</p>		<p>Photo #:</p>	<ul style="list-style-type: none"> • Reconfigure to provide knee space • Lower shelf and/or dispensing device •

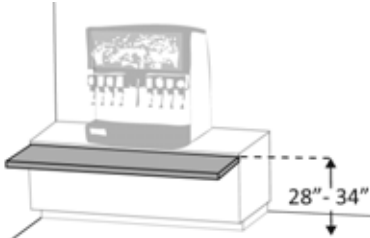
<p>2.88 If there is a tray slide, is the top no less than 28 inches and no greater than 34 inches above the floor? [904.5.2]</p>	<p><input type="checkbox"/> Yes <input type="checkbox"/> No Measurement:</p>	 <p>The diagram shows a tray slide on a counter. A vertical double-headed arrow indicates the height from the floor to the top of the tray slide, labeled as 28" - 34".</p>	<p>Photo #:</p>	<ul style="list-style-type: none"> • Reconfigure • •
	<p><input type="checkbox"/> Yes <input type="checkbox"/> No</p>		<p>Photo #:</p>	<ul style="list-style-type: none"> • • •
	<p><input type="checkbox"/> Yes <input type="checkbox"/> No</p>		<p>Photo #:</p>	<ul style="list-style-type: none"> • • •
	<p><input type="checkbox"/> Yes <input type="checkbox"/> No</p>		<p>Photo #:</p>	<ul style="list-style-type: none"> • • •
	<p><input type="checkbox"/> Yes <input type="checkbox"/> No</p>		<p>Photo #:</p>	<ul style="list-style-type: none"> • • •
	<p><input type="checkbox"/> Yes <input type="checkbox"/> No</p>		<p>Photo #:</p>	<ul style="list-style-type: none"> • • •

The ADA Checklist for Existing Facilities

Priority 3 - Toilet Rooms

Based on the 2010 ADA Standards for Accessible Design

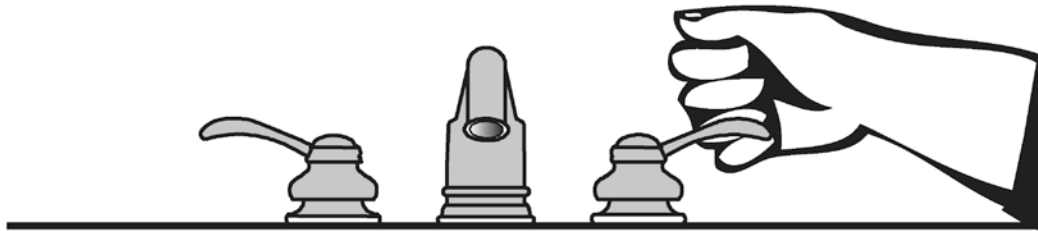

Project _____

Building _____

Location _____

Date _____

Surveyors _____

Contact Information _____

When toilet rooms are open to the public they should be accessible to people with disabilities.



Institute for Human Centered Design
www.HumanCenteredDesign.org

Copyright © 2016





ADA National Network
Questions on the ADA 800-949-4232 voice/tty
www.ADAchecklist.org

This checklist was produced by the New England ADA Center, a project of the Institute for Human Centered Design and a member of the ADA National Network. This checklist was developed under a grant from the Department of Education, NIDRR grant number H133A060092-09A. However the contents do not necessarily represent the policy of the Department of Education, and you should not assume endorsement by the Federal Government.

Questions or comments on the checklist contact the New England ADA Center at 617-695-0085 voice/tty or ADAinfo@NewEnglandADA.org

For the full set of checklists, including the checklists for recreation facilities visit www.ADAchecklist.org.

Copyright © 2016 ADA Checklist for Existing Materials. You can freely reproduce and distribute this content. Include proper attribution. But you must get permission before using this content as a fee-based product.

Priority 3 – Toilet Rooms		Comments	Possible Solutions
<p>3.1 If toilet rooms are available to the public, is at least one toilet room accessible? (Either one for each sex, or one unisex.)</p> <p>Note: If toilet rooms are chiefly for children, e.g., in elementary schools and day care centers, use the children’s specifications in Toilets - 604.1, 604.8, 604.9, 609.4 and Lavatories and Sinks – 606.2.</p>	<input type="checkbox"/> Yes <input type="checkbox"/> No	<p>Photo #:</p>	<ul style="list-style-type: none"> • Reconfigure toilet rooms • Combine toilet rooms to create one unisex accessible toilet room •
<p>3.2 Are there signs at inaccessible toilet rooms that give directions to accessible toilet rooms? [See 2010 ADA Standards for Accessible Design – 216.8]</p>	<input type="checkbox"/> Yes <input type="checkbox"/> No	 <p>Photo #:</p>	<ul style="list-style-type: none"> • Install signs • •
<p>3.3 If not all toilet rooms are accessible, is there a sign at the accessible toilet room with the International Symbol of Accessibility? [216.8]</p>	<input type="checkbox"/> Yes <input type="checkbox"/> No	 <p>Photo #:</p>	<ul style="list-style-type: none"> • Install sign • •
Accessible Route			
<p>3.4 Is there an accessible route to the accessible toilet room? [206.2.4]</p>	<input type="checkbox"/> Yes <input type="checkbox"/> No	<p>Photo #:</p>	<ul style="list-style-type: none"> • Alter route • •

Signs at Toilet Rooms

3.5 Do text characters contrast with their backgrounds? [703.5]

Yes No

Are text characters raised? [703.2]

Yes No

Is there Braille? [703.3]

Yes No

Is the sign mounted:
On the wall on the latch side of the door? [703.4.2]

Yes No

Note: Signs are permitted on the push side of doors with closers and without hold-open devices.

With clear floor space beyond the arc of the door swing and 45-degree open position, at least 18 x 18 inches centered on the tactile characters? * [703.4.2]

Yes No

Measurement:

So the baseline of the lowest character is at least 48 inches above the floor and the baseline of the highest character is no more than 60

Yes No

Measurement:

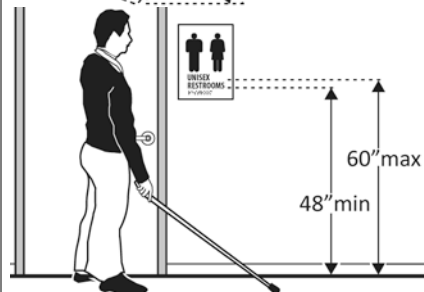
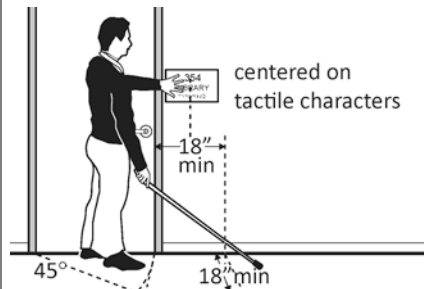
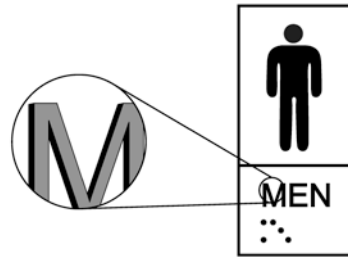

- Install tactile sign
- Relocate sign
-

*If constructed before 3/15/2012 and a person may approach within 3 inches of the sign without encountering protruding objects or standing within the door swing, relocation not required

*If constructed before 3/15/2012 and mounted no higher than 60 inches to the centerline of the sign, relocation is not

<p>inches above the floor? * [703.4.1]</p> <p>Note: If the sign is at double doors with one active leaf, the sign should be on the inactive leaf; if both leaves are active, the sign should be on the wall to the right of the right leaf.</p>			<p>Photo #:</p>	<p>required</p>
-----------------------------------------------------------------------------------------------------------------------------------------------------------------------------------------------------------------------------------------------------	--	--	-----------------	-----------------

Entrance

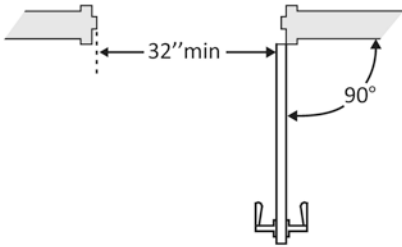

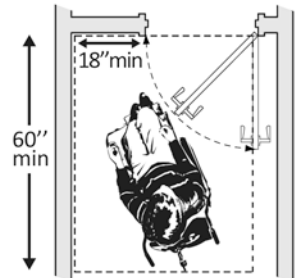
<p>3.6 Is the door opening width at least 32 inches clear, between the face of the door and the stop, when the door is open 90 degrees? [404.2.3]</p>	<p><input type="checkbox"/> Yes <input type="checkbox"/> No</p> <p>Measurement:</p>	 <p>The diagram shows a side view of a door frame. A horizontal arrow indicates a minimum clear width of 32 inches between the door's face and the stop. A curved arrow indicates the door is open at a 90-degree angle.</p>	<p>Photo #:</p>	<ul style="list-style-type: none"> • Install offset hinges • Alter the doorway •
------------------------------------------------------------------------------------------------------------------------------------------------------------------	-------------------------------------------------------------------------------------	----------------------------------------------------------------------------------------------------------------------------------------------------------------------------------------------------------------------------------------------------------------------------------------------------------------	-----------------	-------------------------------------------------------------------------------------------------------------------

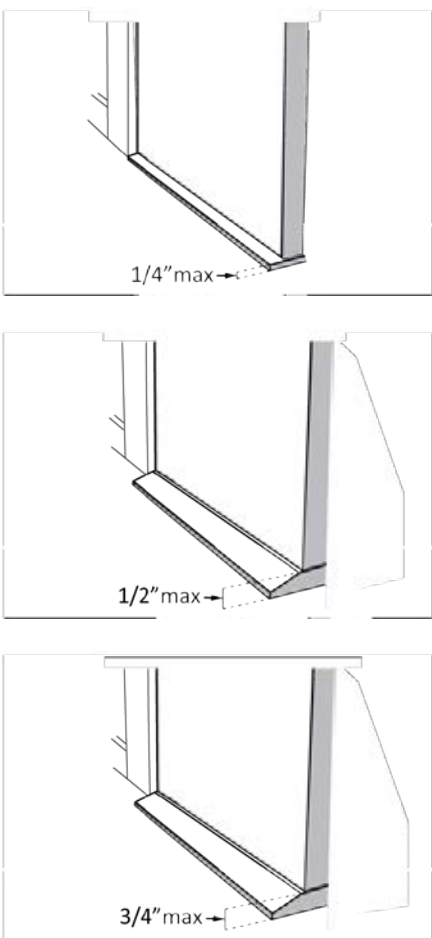
<p>3.7 If there is a front approach to the pull side of the door is there at least 18 inches of maneuvering clearance beyond the latch side plus 60 inches clear depth?</p> <p>Note: See 2010 Standards 404.2.4 for maneuvering clearance requirements on the push side of the door and side approaches to the pull side of the door</p> <p>On both sides of the door, is the floor surface of the</p>	<p><input type="checkbox"/> Yes <input type="checkbox"/> No</p> <p>Measurement:</p> <p><input type="checkbox"/> Yes <input type="checkbox"/> No</p>	 <p>The diagram shows a top-down view of a doorway. A wheelchair is positioned to enter. A horizontal arrow indicates a minimum clear width of 18 inches. A vertical arrow indicates a minimum clear depth of 60 inches.</p>	<p>Photo #:</p>	<ul style="list-style-type: none"> • Remove obstructions • Reconfigure walls • Add automatic door opener
---------------------------------------------------------------------------------------------------------------------------------------------------------------------------------------------------------------------------------------------------------------------------------------------------------------------------------------------------------------------------------------------------------------	-----------------------------------------------------------------------------------------------------------------------------------------------------	------------------------------------------------------------------------------------------------------------------------------------------------------------------------------------------------------------------------------------------------------------------------------------------------------------------	-----------------	-------------------------------------------------------------------------------------------------------------------------------------------

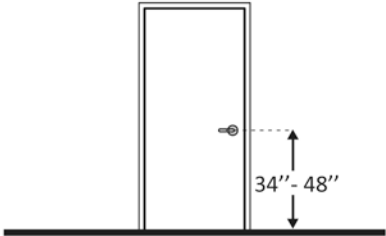
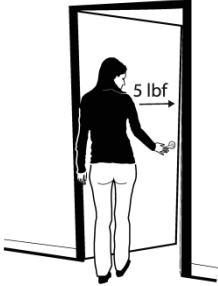
<p>maneuvering clearance level (no steeper than 1:48)? [404.2.4]</p>	<p>Measurement:</p>		<p>Photo #:</p>	
<p>3.8 If the threshold is vertical is it no more than ¼ inch high?</p> <p>Or</p> <p>No more than ½ inch high with the top ¼ inch beveled no steeper than 1:2, if the threshold was installed on or after the 1991 ADA Standards went into effect (1/26/93)?</p> <p>Or</p> <p>No more than ¾ inch high with the top ½ inch beveled no steeper than 1:2, if the threshold was installed before the 1991 ADA Standards went into effect (1/26/93)? [404.2.5, 303.2]</p> <p>Note: The first ¼ inch of the ½ or ¾ inch threshold may be vertical; the rest must be beveled.</p>	<p><input type="checkbox"/> Yes <input type="checkbox"/> No Measurement:</p> <p><input type="checkbox"/> Yes <input type="checkbox"/> No Measurement:</p> <p><input type="checkbox"/> Yes <input type="checkbox"/> No Measurement:</p>		<p>Photo #:</p> <p>Photo #:</p>	<ul style="list-style-type: none"> • Remove or replace threshold • •

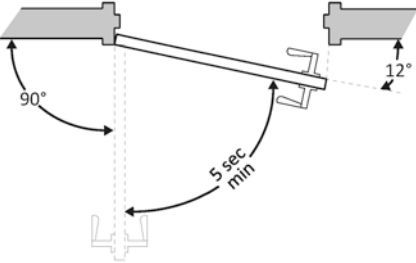
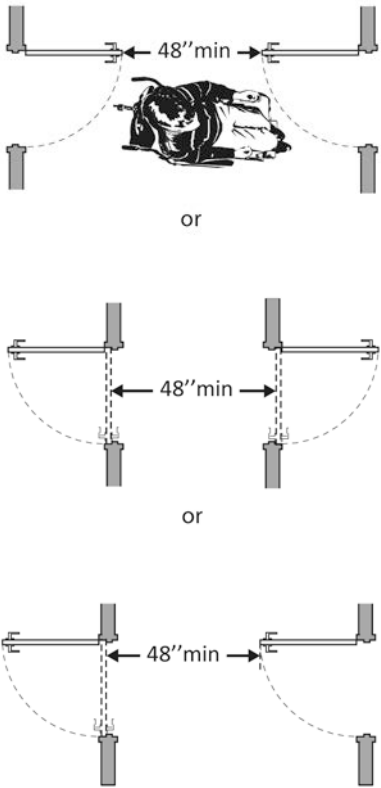
<p>3.9 Is the door equipped with hardware that is operable with one hand and does not require tight grasping, pinching or twisting of the wrist?</p> <p>Door handle?</p> <p>Lock (if provided)? [404.2.7]</p>	<p><input type="checkbox"/> Yes <input type="checkbox"/> No</p>		<p>Photo #:</p>	<ul style="list-style-type: none"> • Replace inaccessible knob with lever, loop or push hardware • Add automatic door opener •
<p>3.10 Are the operable parts of the door hardware mounted no less than 34 inches and no greater than 48 inches above the floor? [404.2.7]</p>	<p><input type="checkbox"/> Yes <input type="checkbox"/> No</p> <p>Measurement:</p>		<p>Photo #:</p>	<ul style="list-style-type: none"> • Change hardware height • •
<p>3.11 Can the door be opened easily (5 pounds maximum force)? [404.2.9]</p> <p>Note: You can use a pressure gauge or fish scale to measure force. If you do not have one you will need to judge whether the door is easy to open.</p>	<p><input type="checkbox"/> Yes <input type="checkbox"/> No</p> <p>Measurement:</p>		<p>Photo #:</p>	<ul style="list-style-type: none"> • Adjust or replace closers • Install lighter doors • Install power-assisted or automatic door openers

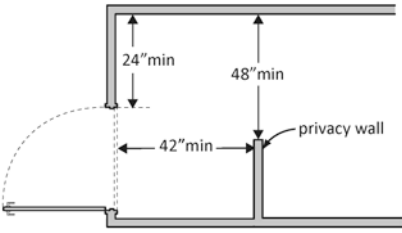
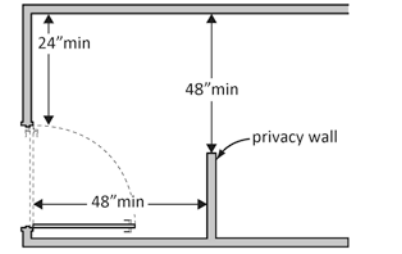
<p>3.12 If the door has a closer, does it take at least 5 seconds to close from an open position of 90 degrees to a position of 12 degrees from the latch? [404.2.8.1]</p>	<p><input type="checkbox"/> Yes <input type="checkbox"/> No Measurement:</p>		<p>Photo #:</p>	<ul style="list-style-type: none"> • Adjust closer • •
<p>3.13 If there are two doors in a series, e.g. vestibule, is the distance between the doors at least 48 inches plus the width of the doors when swinging into the space? [404.2.6]</p>	<p><input type="checkbox"/> Yes <input type="checkbox"/> No Measurement:</p>		<p>na</p> <p>Photo #:</p>	<ul style="list-style-type: none"> • Remove inner door • Change door swing •

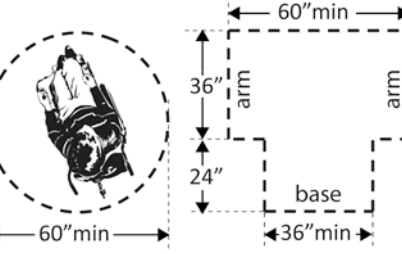
<p>3.14 If there is a privacy wall and the door swings out, is there at least 24 inches of maneuvering clearance beyond the door latch side and 42 inches to the privacy wall? [404.2.4]</p>	<p><input type="checkbox"/> Yes <input type="checkbox"/> No Measurement:</p>		<p>Photo #:</p>	<ul style="list-style-type: none"> • Reconfigure space • •
<p>3.15 If there is a privacy wall and the door swings in, is there at least 24 inches of maneuvering clearance beyond the door latch side and at least 48 inches to the privacy wall if there is no door closer or at least 54 inches if there is a door closer? [404.2.4]</p>	<p><input type="checkbox"/> Yes <input type="checkbox"/> No Measurement:</p>		<p>Photo #:</p>	<ul style="list-style-type: none"> • Reconfigure space • •
<p>In the Toilet Room</p>				
<p>3.16 Is there a clear path to at least one of each type of fixture, e.g. lavatory, hand dryer, etc., that is at least 36 inches wide? [403.5.1]</p>	<p><input type="checkbox"/> Yes <input type="checkbox"/> No Measurement:</p>		<p>Photo #:</p>	<ul style="list-style-type: none"> • Remove obstructions • •
<p>3.17 Is there clear floor space available for a person in a wheelchair to turn around, i.e. a circle at least 60 inches in diameter or a T-shaped space within a 60-inch square? [603.2.1]</p>	<p><input type="checkbox"/> Yes <input type="checkbox"/> No Measurement:</p>		<p>Photo #:</p>	<ul style="list-style-type: none"> • Move or remove partitions, fixtures or objects such as trash cans • •

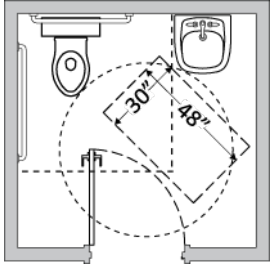
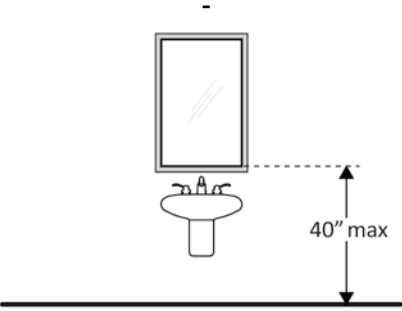
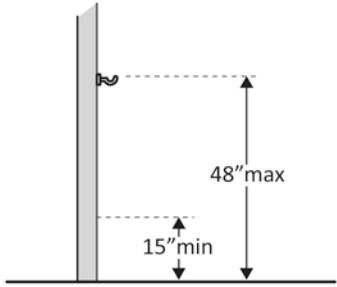
<p>3.18 In a single user toilet room if the door swings in and over a clear floor space at an accessible fixture, is there a clear floor space at least 30 x 48 inches beyond the swing of the door? [603.2.3 Exception 2]</p>	<p><input type="checkbox"/> Yes <input type="checkbox"/> No</p> <p>Measurement:</p>		<p>Photo #:</p>	<ul style="list-style-type: none"> • Reverse door swing • Alter toilet room •
<p>3.19 If the mirror is over a lavatory or countertop, is the bottom edge of the reflecting surface no higher than 40 inches above the floor? Or If the mirror is not over the lavatory or countertop, is the bottom edge of the reflecting surface no higher than 35 inches above the floor?*</p>	<p><input type="checkbox"/> Yes <input type="checkbox"/> No</p> <p>Measurement:</p> <p><input type="checkbox"/> Yes <input type="checkbox"/> No</p> <p>Measurement:</p>		<p>Photo #:</p>	<p>* If installed before 3/15/2012 and the bottom edge of the reflecting surface is no higher than 40 inches above the floor, lowering the mirror to 35 inches is not required</p> <ul style="list-style-type: none"> • Lower the mirror • Add another mirror •
<p>3.20 If there is a coat hook, is it no less than 15 inches and no greater than 48 inches above the floor?*</p>	<p><input type="checkbox"/> Yes <input type="checkbox"/> No</p> <p>Measurement:</p>		<p>Photo #:</p>	<ul style="list-style-type: none"> • Adjust hook • Replace with or provide additional accessible hook • <p>* If installed before 3/15/2010 and the clear floor space allows a parallel approach, the coat hook may be 54 inches above the floor.</p>

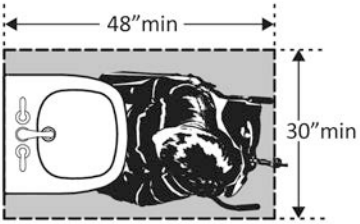
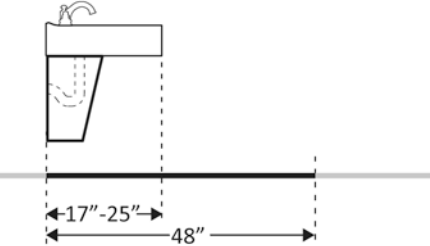
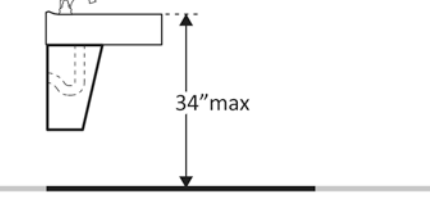
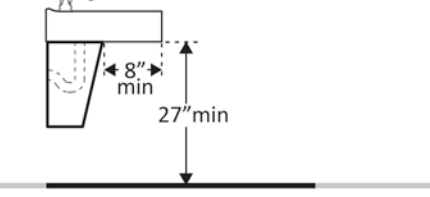
Lavatories The 2010 Standards refer to sinks in toilet rooms as lavatories.				
<p>3.21 Does at least one lavatory have a clear floor space for a forward approach at least 30 inches wide and 48 inches long? [606.2]</p>	<p><input type="checkbox"/> Yes <input type="checkbox"/> No</p> <p>Measurement:</p>		<p>Photo #:</p>	<ul style="list-style-type: none"> • Alter lavatory • Replace lavatory •
<p>3.22 Do no less than 17 inches and no greater than 25 inches of the clear floor space extend under the lavatory so that a person using a wheelchair can get close enough to reach the faucet? [306.2]</p>	<p><input type="checkbox"/> Yes <input type="checkbox"/> No</p> <p>Measurement:</p>		<p>Photo #:</p>	<ul style="list-style-type: none"> • Alter lavatory • Replace lavatory •
<p>3.23 Is the front of the lavatory or counter surface, whichever is higher, no more than 34 inches above the floor? [606.3]</p>	<p><input type="checkbox"/> Yes <input type="checkbox"/> No</p> <p>Measurement:</p>		<p>Photo #:</p>	<ul style="list-style-type: none"> • Alter lavatory • Replace lavatory •
<p>3.24 Is there at least 27 inches clearance from the floor to the bottom of the lavatory that extends at least 8 inches under the lavatory for knee clearance? [306.3.3]</p>	<p><input type="checkbox"/> Yes <input type="checkbox"/> No</p> <p>Measurement:</p>		<p>Photo #:</p>	<ul style="list-style-type: none"> • Alter lavatory • Replace lavatory •

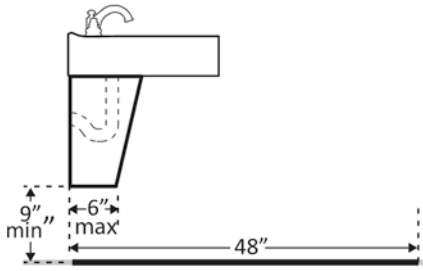
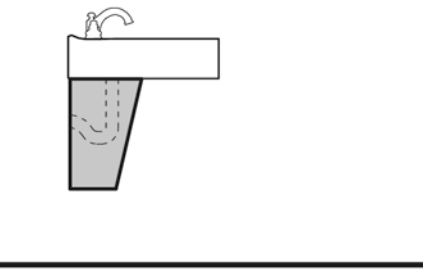
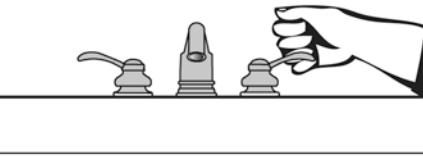
<p>3.25 Is there toe clearance at least 9 inches high? [306.3.3]</p> <p>Note: Space extending greater than 6 inches beyond the available toe clearance at 9 inches above the floor is not considered toe clearance.</p>	<p><input type="checkbox"/> Yes <input type="checkbox"/> No</p> <p>Measurement:</p>		<p>Photo #:</p>	<ul style="list-style-type: none"> • Alter lavatory • Replace lavatory •
<p>3.26 Are pipes below the lavatory insulated or otherwise configured to protect against contact? [606.5]</p>	<p><input type="checkbox"/> Yes <input type="checkbox"/> No</p>		<p>Photo #:</p>	<ul style="list-style-type: none"> • Install insulation • Install cover panel •
<p>3.27 Can the faucet be operated without tight grasping, pinching, or twisting of the wrist?</p> <p>Is the force required to activate the faucet no greater than 5 pounds? [606.4]</p>	<p><input type="checkbox"/> Yes <input type="checkbox"/> No</p> <p><input type="checkbox"/> Yes <input type="checkbox"/> No</p>		<p>Photo #:</p>	<ul style="list-style-type: none"> • Adjust faucet • Replace faucet •

Soap Dispensers and Hand Dryers

3.28 Are the operable parts of the soap dispenser within one of the following reach ranges:

Above lavatories or counters no less than 20 inches and no greater than 25 inches deep: no higher than 44 inches above the floor?
[308.2.2]

Yes No
Measurement:

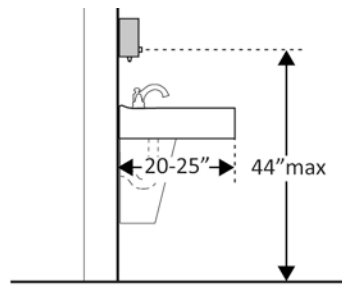

Above lavatories less than 20 inches deep: no higher than 48 inches above the floor?

Not over an obstruction: no higher than 48 inches above the floor?
[308.2]

Yes No
Measurement:

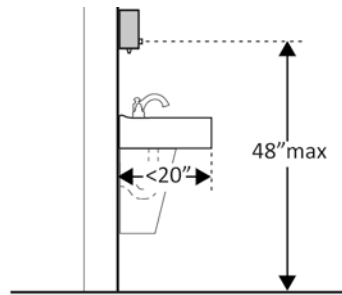

Yes No
Measurement:

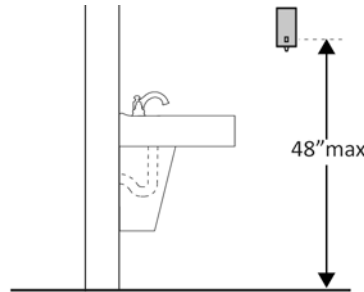

Photo #:

- Adjust dispensers
- Replace with or provide additional accessible dispensers
-

3.29 Are the operable parts of the hand dryer or towel dispenser within one of the following reach ranges:

Above lavatories or counters no less than 20 inches and no greater than 25 inches deep: no higher than 44 inches above the

Yes No
Measurement:

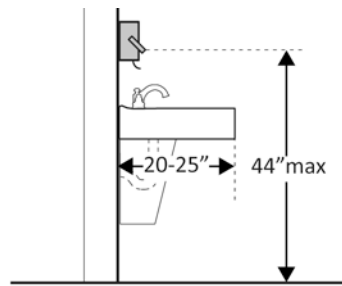

- Adjust dispensers
- Replace with or provide additional accessible dispensers
-

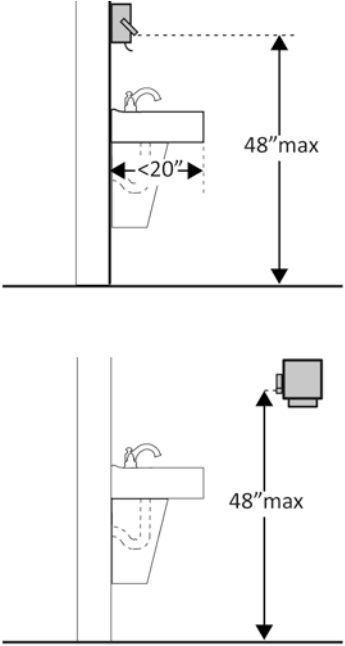
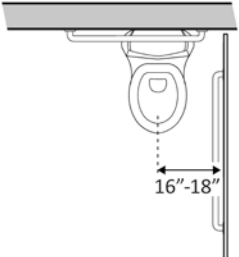
<p>floor?</p> <p>Above lavatories less than 20 inches deep: no higher than 48 inches above the floor?</p> <p>Not over an obstruction: no higher than 48 inches above the floor? [308.2]</p> <p>Can the operable parts of the hand dryer or towel dispenser be operated without tight grasping, pinching or twisting of the wrist?</p> <p>Is the force required to activate the hand dryer or towel dispenser no greater than 5 pounds? [309.4]</p>	<p><input type="checkbox"/> Yes <input type="checkbox"/> No Measurement:</p> <p><input type="checkbox"/> Yes <input type="checkbox"/> No Measurement:</p> <p><input type="checkbox"/> Yes <input type="checkbox"/> No</p> <p><input type="checkbox"/> Yes <input type="checkbox"/> No Measurement:</p>		<p>Photo #:</p>	
<p>Water Closets in Single-User Toilet Rooms and Compartments (Stalls) The 2010 Standards refer to toilets as water closets.</p>				
<p>3.30 Is the centerline of the water closet no less than 16 inches and no greater than 18 inches from the side wall or partition? [604.2]</p>	<p><input type="checkbox"/> Yes <input type="checkbox"/> No Measurement:</p>		<p>Photo #:</p>	<ul style="list-style-type: none"> • Move toilet • Replace toilet • Move partition •

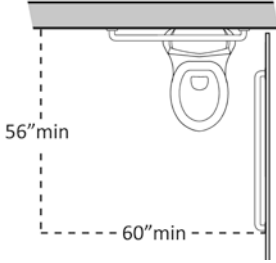
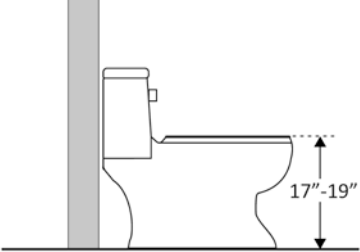
<p>3.31 Is clearance provided around the water closet measuring at least 60 inches from the side wall and at least 56 inches from the rear wall?*</p> <p>[604.3.1]</p>	<p><input type="checkbox"/> Yes <input type="checkbox"/> No</p> <p>Measurement:</p>		<p>Photo #:</p> <p>* If constructed before 3/15/12, clearances around water closets in single user toilet rooms can be 48 inches wide by 66 inches long or 48 inches wide by 56 inches long (depending on the approach to the water closet, see 1991 Standards Figure 28) and the lavatory may overlap that clearance if the door to the room does not swing into the required clearances at fixtures (such as lavatories, water closet and urinals) and the edge of the lavatory is at least 18 inches from the centerline of the water closet</p> <ul style="list-style-type: none"> • Alter room/compartment for clearance • •
<p>3.32 Is the height of the water closet no less than 17 inches and no greater than 19 inches above the floor measured to the top of the seat?</p> <p>[604.4]</p>	<p><input type="checkbox"/> Yes <input type="checkbox"/> No</p> <p>Measurement:</p>		<p>Photo #:</p> <ul style="list-style-type: none"> • Adjust toilet height • Replace toilet •

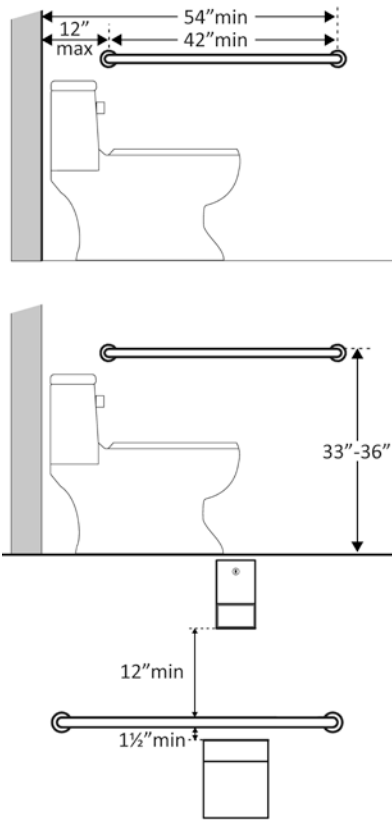
<p>3.33 Is there a grab bar at least 42 inches long on the side wall?</p> <p>Is it located no more than 12 inches from the rear wall?</p> <p>Does it extend at least 54 inches from the rear wall? [604.5.1]</p> <p>Is it mounted no less than 33 inches and no greater than 36 inches above the floor to the top of the gripping surface? [609.4]</p> <p>Is there at least 12 inches clearance between the grab bar and projecting objects above?*</p> <p>Is there at least 1½ inches clearance between the grab bar and projecting objects below?*</p> <p>Is the space between the wall and the grab bar 1 ½ inches? [609.3]</p>	<p><input type="checkbox"/> Yes <input type="checkbox"/> No Measurement:</p> <p><input type="checkbox"/> Yes <input type="checkbox"/> No Measurement:</p> <p><input type="checkbox"/> Yes <input type="checkbox"/> No Measurement:</p> <p><input type="checkbox"/> Yes <input type="checkbox"/> No Measurement:</p> <p><input type="checkbox"/> Yes <input type="checkbox"/> No Measurement:</p> <p><input type="checkbox"/> Yes <input type="checkbox"/> No Measurement:</p> <p><input type="checkbox"/> Yes <input type="checkbox"/> No Measurement:</p>	 <p>The diagrams illustrate the following requirements for a side wall grab bar:</p> <ul style="list-style-type: none"> Length: The grab bar must be at least 42 inches long and no more than 54 inches long. Distance from Rear Wall: The grab bar must be located no more than 12 inches from the rear wall. Height: The grab bar must be mounted no less than 33 inches and no greater than 36 inches above the floor to the top of the gripping surface. Clearance Above: There must be at least 12 inches of clearance between the grab bar and any projecting objects above it. Clearance Below: There must be at least 1½ inches of clearance between the grab bar and any projecting objects below it. 	<p>Photo #:</p>	<ul style="list-style-type: none"> • Install grab bar • Relocate grab bar • Relocate objects • <p>* If constructed before 3/15/2012 grab bars do not need to be relocated; there are no space requirements above and below grab bars in the 1991 Standards</p>
-------------------------------------------------------------------------------------------------------------------------------------------------------------------------------------------------------------------------------------------------------------------------------------------------------------------------------------------------------------------------------------------------------------------------------------------------------------------------------------------------------------------------------------------------------------------------------------------------------------------------------------------	----------------------------------------------------------------------------------------------------------------------------------------------------------------------------------------------------------------------------------------------------------------------------------------------------------------------------------------------------------------------------------------------------------------------------------------------------------------------------------------------------------------------------------------------------------------------------------------	-----------------------------------------------------------------------------------------------------------------------------------------------------------------------------------------------------------------------------------------------------------------------------------------------------------------------------------------------------------------------------------------------------------------------------------------------------------------------------------------------------------------------------------------------------------------------------------------------------------------------------------------------------------------------------------------------------------------------------------------------------------------------------------------------------------------------------------------------------------------------------------------	-----------------	----------------------------------------------------------------------------------------------------------------------------------------------------------------------------------------------------------------------------------------------------------------------------------------------------------

<p>3.34 Is there a grab bar at least 36 inches long on the rear wall?</p> <p>Does it extend at least 12 inches from the centerline of the water closet on one side (side wall)?</p> <p>Does it extend at least 24 inches on the other (open) side? [604.5.2]</p> <p>Is it mounted no less than 33 inches and no greater than 36 inches above the floor to the top of the gripping surface? [609.4]</p> <p>Are there at least 12 inches clearance between the grab bar and protruding objects above?*</p> <p>Are there at least 1½ inches clearance between the grab bar and projecting objects below?*</p> <p>Is the space between the wall and the grab bar 1½ inches? [609.3]</p>	<p><input type="checkbox"/> Yes <input type="checkbox"/> No Measurement:</p> <p><input type="checkbox"/> Yes <input type="checkbox"/> No Measurement:</p> <p><input type="checkbox"/> Yes <input type="checkbox"/> No Measurement:</p> <p><input type="checkbox"/> Yes <input type="checkbox"/> No Measurement:</p> <p><input type="checkbox"/> Yes <input type="checkbox"/> No Measurement:</p> <p><input type="checkbox"/> Yes <input type="checkbox"/> No Measurement:</p> <p><input type="checkbox"/> Yes <input type="checkbox"/> No Measurement:</p>		<p>Photo #:</p>	<ul style="list-style-type: none"> • Install grab bar • Relocate grab bar • Relocate objects • <p>* If constructed before 3/15/2012 grab bars do not need to be relocated; there are no space requirements above and below grab bars in the 1991 Standards</p>
--------------------------------------------------------------------------------------------------------------------------------------------------------------------------------------------------------------------------------------------------------------------------------------------------------------------------------------------------------------------------------------------------------------------------------------------------------------------------------------------------------------------------------------------------------------------------------------------------------------------------------------------------------------------------------------------------------	----------------------------------------------------------------------------------------------------------------------------------------------------------------------------------------------------------------------------------------------------------------------------------------------------------------------------------------------------------------------------------------------------------------------------------------------------------------------------------------------------------------------------------------------------------------------------------------	--	-----------------	----------------------------------------------------------------------------------------------------------------------------------------------------------------------------------------------------------------------------------------------------------------------------------------------------------

<p>3.35 If the flush control is hand operated, is the operable part located no higher than 48 inches above the floor? [604.6]</p>	<p><input type="checkbox"/> Yes <input type="checkbox"/> No Measurement:</p>		<p>Photo #:</p>	<ul style="list-style-type: none"> • Move control • Install sensor with override button no higher than 48 inches •
<p>3.36 If the flush control is hand operated, can it be operated with one hand and without tight grasping, pinching, or twisting of the wrist? Is the force required to activate the flush control no greater than 5 pounds? [605.4]</p>	<p><input type="checkbox"/> Yes <input type="checkbox"/> No <input type="checkbox"/> Yes <input type="checkbox"/> No Measurement:</p>		<p>Photo #:</p>	<ul style="list-style-type: none"> • Change control • Adjust control •
<p>3.37 Is the flush control on the open side of the water closet? [604.6]</p>	<p><input type="checkbox"/> Yes <input type="checkbox"/> No</p>		<p>Photo #:</p>	<ul style="list-style-type: none"> • Move control • •
<p>3.38 Is the toilet paper dispenser located no less than 7 inches and no greater than 9 inches from the front of the water closet to the centerline of the dispenser?*</p>	<p><input type="checkbox"/> Yes <input type="checkbox"/> No Measurement:</p>		<p>Photo #:</p>	<p>* If constructed before 3/15/2012 dispenser does not need to be relocated if it is within reach from the water closet seat; the 1991 Standards do not specify distance from the front of the water closet</p>

			Photo #:	<ul style="list-style-type: none"> • Relocate dispenser • •
<p>3.39 Is the outlet of the dispenser:</p> <p>Located no less than 15 inches and no greater than 48 inches above the floor?</p> <p><input type="checkbox"/> Yes <input type="checkbox"/> No</p> <p>Measurement:</p> <p>Not located behind grab bars? [604.7]</p> <p><input type="checkbox"/> Yes <input type="checkbox"/> No</p>			Photo #:	<ul style="list-style-type: none"> • Relocate dispenser • •
<p>3.40 Does the dispenser allow continuous paper flow? [604.7]</p> <p><input type="checkbox"/> Yes <input type="checkbox"/> No</p>			Photo #:	<ul style="list-style-type: none"> • Adjust dispenser • Replace dispenser •
Toilet Compartments (Stalls)				
<p>3.41 Is the door opening width at least 32 inches clear, between the face of the door and the stop, when the door is open 90 degrees? [604.8.1.2]</p> <p><input type="checkbox"/> Yes <input type="checkbox"/> No</p> <p>Measurement:</p>			Photo #:	<ul style="list-style-type: none"> • Widen door width • •

<p>3.42 If there is a front approach to the pull side of the door, is there at least 18 inches of maneuvering clearance beyond the latch side plus 60 inches clear depth? [604.8.1.2]</p> <p>Note: See 2010 Standards 604.8.1.2 Doors for maneuvering clearance requirements on the push side of the door and side approaches to the pull side of the door</p>	<p><input type="checkbox"/> Yes <input type="checkbox"/> No</p> <p>Measurement:</p>		<p>Photo #:</p>	<ul style="list-style-type: none"> • Remove obstructions • •
<p>3.43 Is the door self-closing? [604.8.1.2]</p>	<p><input type="checkbox"/> Yes <input type="checkbox"/> No</p>		<p>Photo #:</p>	<ul style="list-style-type: none"> • Add closer • Replace door •
<p>3.44 Are there door pulls on both sides of the door that are operable with one hand and do not require tight grasping pinching or twisting of the wrist?*</p> <p>[604.8.1.2]</p>	<p><input type="checkbox"/> Yes <input type="checkbox"/> No</p>		<p>Photo #:</p>	<p>* If constructed before 3/15/2012 door pulls do not need to be added; door pulls are not required in the 1991 Standards</p> <ul style="list-style-type: none"> • Replace hardware • •

<p>3.45 Is the lock operable with one hand and without tight grasping, pinching or twisting of the wrist? [309.4]</p>	<p><input type="checkbox"/> Yes <input type="checkbox"/> No</p>		<p>Photo #:</p>	<ul style="list-style-type: none"> • Replace lock • •
<p>3.46 Are the operable parts of the door hardware mounted no less than 34 inches and no greater than 48 inches above the floor? [404.2.7]</p>	<p><input type="checkbox"/> Yes <input type="checkbox"/> No Measurement:</p>		<p>Photo #:</p>	<ul style="list-style-type: none"> • Relocate hardware • •
<p>3.47 Is the compartment at least 60 inches wide? [604.8.1.1]</p>	<p><input type="checkbox"/> Yes <input type="checkbox"/> No Measurement:</p>		<p>Photo #:</p>	<ul style="list-style-type: none"> • Widen compartment • •
<p>3.48 If the water closet is wall hung, is the compartment at least 56 inches deep? [604.8.1.1]</p>	<p><input type="checkbox"/> Yes <input type="checkbox"/> No Measurement:</p>		<p>Photo #:</p>	<ul style="list-style-type: none"> • Widen compartment • •

<p>3.49 If the water closet is floor mounted, is the compartment at least 59 inches deep? [604.8.1.1]</p>	<p><input type="checkbox"/> Yes <input type="checkbox"/> No Measurement:</p>		<p>Photo #:</p>	<ul style="list-style-type: none"> • Alter compartment • •
<p>3.50 If the door swings in, is the minimum required compartment area provided beyond the swing of the door (60 inches x 56 inches if water closet is wall hung or 59 inches if water closet is floor mounted)? [604.8.1.1]</p>	<p><input type="checkbox"/> Yes <input type="checkbox"/> No Measurement:</p>		<p>Photo #:</p>	<ul style="list-style-type: none"> • Reverse door swing • Alter compartment •
	<p><input type="checkbox"/> Yes <input type="checkbox"/> No</p>		<p>Photo #:</p>	<ul style="list-style-type: none"> • • •
	<p><input type="checkbox"/> Yes <input type="checkbox"/> No</p>		<p>Photo #:</p>	<ul style="list-style-type: none"> • • •
	<p><input type="checkbox"/> Yes <input type="checkbox"/> No</p>		<p>Photo #:</p>	<ul style="list-style-type: none"> • • •

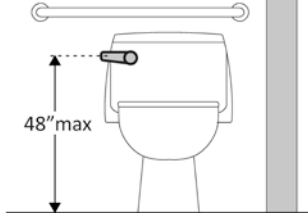
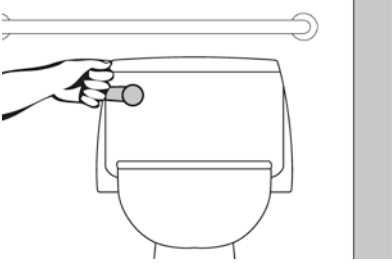
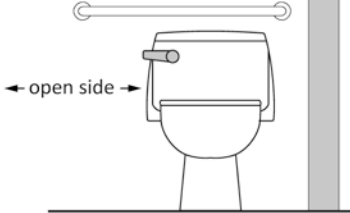
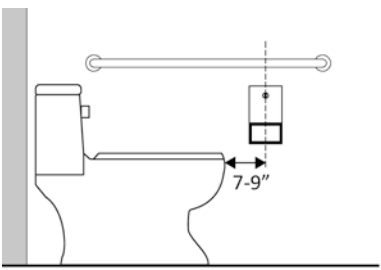
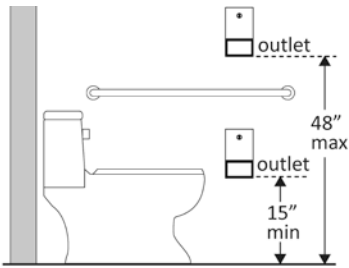
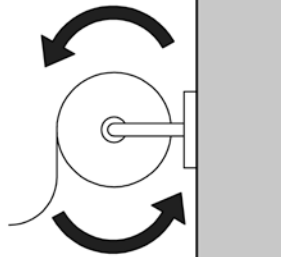
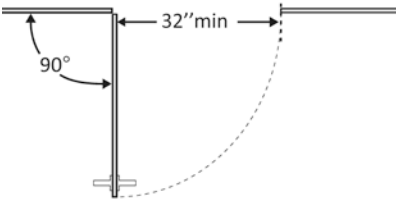
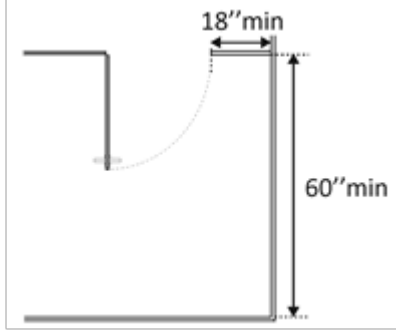
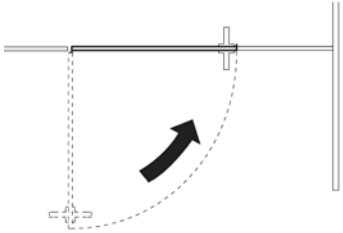
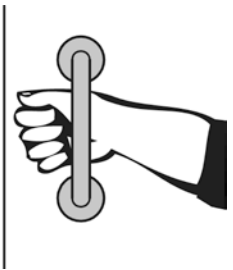
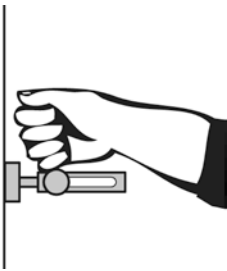
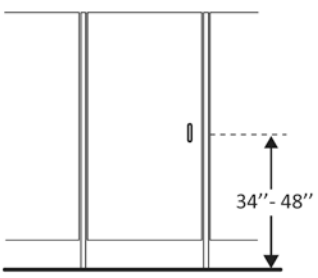
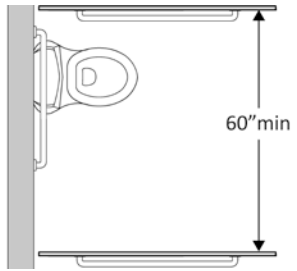
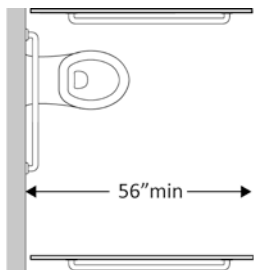
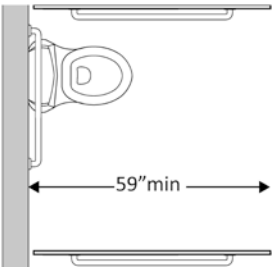
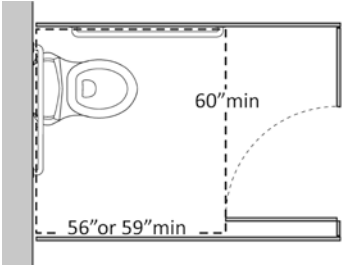
APPENDIX 2: FACILITIES TRANSITION PLAN



Accessibility Ranking

Rating	Description
0	Existing lot is signed and striped appropriately with adequate number of spaces. Some locations are at service yards where parking is not signed but also not an issue. No timeline required.
1	High priority project, often in a high use area. Accessible spaces may not exist or may be present with incorrect signage and striping. These projects are usually an easy fix. Recommend year 1 to 2 implementation.
2	Priority project, often in a high use area. Accessible spaces may not exist or may be present with incorrect signage and striping. Additional spaces may be needed. Recommend year 3 to 4 implementation.
3	Medium priority project, often in a medium use area. Accessible spaces may not exist or may be present with incorrect signage and striping. Additional spaces may be needed. Recommend year 5 to 6 implementation.
4	Low priority project, often in a low use area. Accessible spaces may not exist or may be present but located in the wrong location. Project often requires a little more work because there is nothing present at this time. Recommend year 7 to 8 implementation.
5	Extremely low priority project, often in a low use area. Accessible spaces are often not present and not needed. These are often in little used parking lots, sometimes aggregate lots. Recommend year 9 to 10 implementation.

PRIORITY 1. PRIMARY RECREATIONAL VISITOR APPROACH AND ENTRANCE AREAS

Park	Location	Total Spaces	Total # of HC Spaces	# that are Van Accessible	Required HC Spaces	Required Van Spaces	Space Meet All Requirements	Notes	Cost	Timeline	Priority Ranking
Delhi	Skips Canoe Livery	38	2	0	2	1	Yes	Appears to meet all requirements	456	Completed 2019	0
Delhi	East Delhi - North Lot	75	6	2	3	1	Yes	Appears to meet all requirements	456	Completed 2019	0
Dexter-Huron	Southeast Lot	45	2	1	2	1	Yes	Restriping needed.	893	Completed 2019	0
Dexter-Huron	Northwest Lot	32	2	1	2	1	Yes	Appears to meet all requirements	893	Completed 2019	0
Dexter-Huron	Northeast Lot	42	2	1	2	1	Yes	Appears to meet all requirements	893	Completed 2019	0
Hudson Mills	Activity Center West	306	8	4	8	2	Yes	Appear to meet all standards. Old striping is showing through.	1,248	Completed 2019	0
Hudson Mills	Activity Center East							Parking lot totals have been grouped with the west lot.	1,248	Completed 2019	0
Hudson Mills	River Grove	94	4	2	4	1	Yes	Appears to meet all requirements	1,248	Completed 2019	0
Hudson Mills	Golf Course	128	5	1	5	1	Yes	Appears to meet all requirements	1,248	Completed 2019	0
Hudson Mills	Pine View	70	3	1	3	1	Yes	Appears to meet all requirements	1,248	Completed 2019	0
Huron Meadows	Acorn Ridge	53	5	1	3	1	Yes	Appears to meet all standards	1,192	Completed 2019	0
Huron Meadows	Acorn Ridge	53	5	1	3	1	Yes	Appears to meet standards	1,192	Completed 2019	0
Huron Meadows	Sunset Ridge	55	3	1	2	1	Yes	Appears to meet all requirements	1,192	Completed 2019	0
Huron Meadows	Golf Course	118	5	1	5	1	Yes	Appears to meet all requirements	1,192	Completed 2019	0
Huron Meadows	Cedar Ridge	38	2	1	2	1	Yes	Appears to meet all requirements	1,192	Completed 2019	0
Indian Springs	Golf Course	116	5	5	5	1	Yes	Appears to meet all requirements.	Not available	Completed 2018?	0
Indian Springs	South Meadowlark	100	4	4	4	1	Yes	Appears to meet all requirements. Recommend moving spaces closer to the shelter when access walks are constructed.	Not available	Completed 2018?	0
Indian Springs	North Meadowlark	91	4	2	4	2	Yes	Appear to met all requirements.	Not available	Completed 2018?	0
Indian Springs	Environmental Discovery Center	103	7	7	5	1	Yes	Appears to meet all requirements.	Not available	Completed 2018?	0
Kensington	Administrative Office	74	3	1	3	1	Yes	Appears to meet all requirements	1,040	Completed 2019	0
Kensington	West Boat Launch	208	10	4	7	2	Yes	Appears to meet all requirements.	1,040	Completed 2019	0
Kensington	Nature Center	92	5	1	4	1	Yes	Appears to meet all requirements.	1,040	Completed 2019	0
Kensington	Baywoods	196	7	2	7	2	Yes	Appears to meet all requirements	1,040	Completed 2019	0
Kensington	Spring Hill	59	4	1	3	1	Yes	Appears to meet all standards	1,040	Completed 2019	0
Kensington	Farm Center	117	6	2	5	1	Yes	Recommend grouping with the Farm Center Overflow lot total. 181 spaces will require 6 accessible spaces.	1,040	Completed 2019	0
Kensington	Farm Center Overflow	60	0	0	0	0	Yes	Accessible spaces may be needed. Recommend grouping with the Farm Center parking lot total.	1,040	Completed 2019	0
Kensington	Shore Fishing	96	4	1	4	1	Yes	Appears to meet all standards	1,040	Completed 2019	0
Kensington	North Martindale	388	11	5	8	1	Yes	Appears to meet standards	1,040	Completed 2019	0
Kensington	South Martindale	395	8	2	8	1	Yes	Appears to meet standards	1,040	Completed 2019	0
Kensington	East Boat Launch Upper Lot	100	5	2	4	1	Yes	Appears to meet standards	1,040	Completed 2019	0
Kensington	Golf Course	123	5	1	4	1	Yes	Appears to meet all requirements	1,040	Completed 2019	0
Kensington	Boat Rental	191	6	2	5	1	Yes	Appears to meet all requirements	1,040	Completed 2019	0
Kensington	Maple Beach	631	13	3	10	3	Yes	Appears to meet all requirements	1,040	Completed 2019	0
Kensington	Playfield East	36	2	1	2	1	Yes	Appears to meet all requirements	1,040	Completed 2019	0
Kensington	East Boat Launch Lower Lot	65	6	2	2	1	Yes	Appears to meet all requirements	1,040	Completed 2019	0
Kensington	North Hickory	64	3	1	3	1	Yes	Appears to meet all requirements	1,040	Completed 2019	0
Kensington	Playfield North	52	3	1	3	1	Yes	Appears to meet all requirements	1,040	Completed 2019	0
Kensington	South Hickory	101	5	1	5	1	Yes	Appears to meet all requirements	1,040	Completed 2019	0
Kensington	Turtlehead	131	6	2	5	1	Yes	Appears to meet all requirements	1,040	Completed 2019	0
Kensington	Possum Hollow Restroom	158	7	3	6	1	Yes	Appears to meet all requirements	1,040	Completed 2019	0
Kensington	East Boat Launch / South Martindale	65	6	1	6	1	Yes	Appears to meet all requirements	1,040	Completed 2019	0
Kensington	Orchard	74	4	1	3	1	Yes	Appears to meet all requirements	1,040	Completed 2019	0
Lake Erie	Cove Point (Muskrat Shelter)	34	2	2	2	1	Yes	Appears to meet all requirements.	673	Completed 2019	0
Lake Erie	Cove Point (Wood Duck Shelter and Restroom)	110	5	1	5	1	Yes	Appears to meet all requirements.	673	Completed 2019	0
Lake Erie	Marshlands Museum	141	4	1	5	1	Yes	Appears to meet all requirements	673	Completed 2019	0
Lake Erie	Great Wave Area (bathhouse, pool, food bar)	382	18	4	8	2	Yes	Appears to meet all requirements	673	Completed 2019	0
Lake Erie	Marina Point Fishing Pier	4	2	1	1	1	Yes	Appears to meet all requirements	673	Completed 2019	0
Lake Erie	Marina	182	10	4	6	1	Yes	Appears to meet all requirements	673	Completed 2019	0

PRIORITY 1. PRIMARY RECREATIONAL VISITOR APPROACH AND ENTRANCE AREAS

Park	Location	Total Spaces	Total # of HC Spaces	# that are Van Accessible	Required HC Spaces	Required Van Spaces	Space Meet All Requirements	Notes	Cost	Timeline	Priority Ranking
Lake Erie	Golf Course	158	8	3	6	1	Yes	Appears to meet all requirements	673	Completed 2019	0
Lake Erie	Boat Launch	196	7	2	6	1	Yes	Appears to meet all requirements	673	Completed 2019	0
Lake St. Clair	Nature Center	141	6	2	5	1	Yes	Appears to meet all requirements.	1,185	Completed 2019	0
Lake St. Clair	Lot A (Golf Course)	306	8	6	8	2	Yes	Appears to meet all requirements.	1,185	Completed 2019	0
Lake St. Clair	Daysail	126	6	3	5	1	Yes	Appears to meet all requirements	1,185	Completed 2019	0
Lake St. Clair	Lot B	631	14	4	13	2	Yes	Appears to meet all requirements	1,185	Completed 2019	0
Lake St. Clair	Lot C	458	12	2	9	2	Yes	Appears to meet all requirements	1,185	Completed 2019	0
Lake St. Clair	Lot D	86	2	2	3	1	Yes	Appears to meet all requirements	1,185	Completed 2019	0
Lake St. Clair	Lot E	601	14	4	13	3	Yes	Appears to meet all requirements	1,185	Completed 2019	0
Lower Huron	Ellwoods North	161	6	3	6	1	Yes	Appears to meet all requirements. The combined total of 182 spaces require 6 accessible spaces. Striped aisles should be centered on the walks in the future.	539	Completed 2019	0
Lower Huron	North Fishing Site	20	1	1	1	1	Yes	Appears to meet all requirements.	539	Completed 2019	0
Lower Huron	Tulip Tree North	21	2	1	1	1	Yes	Appears to meet all requirements.	539	Completed 2019	0
Lower Huron	Tulip Tree South	43	4	3	3	1	Yes	Appears to meet all requirements.	539	Completed 2019	0
Lower Huron	Turtle Cove	269	8	4	7	2	Yes	Appears to meet all requirements.	539	Completed 2019	0
Lower Huron	Walnut Grove Lot 1	42	4	2	2	1	Yes	Both parking areas appear to meet all requirements. Recommend moving the dumpster that is in the striped van aisle closest to the shelter.	539	Completed 2019	0
Lower Huron	Bob White Trail Lot	13	2	1	1	1	Yes	Appears to meet all requirements	539	Completed 2019	0
Lower Huron	East Bend	49	2	1	2	1	Yes	Appears to meet all requirements	539	Completed 2019	0
Lower Huron	Woods Creek South	334	6	3	8	3	Yes	Appears to meet all requirements	539	Completed 2019	0
Lower Huron	South Fishing Site	23	2	1	1	1	Yes	Appears to meet all requirements	539	Completed 2019	0
Lower Huron	Fox Woods	150	4	2	5	1	Yes	Appears to meet all requirements	539	Completed 2019	0
Lower Huron	Hawthorn Glade	140	5	1	5	1	Yes	Appears to meet all requirements	539	Completed 2019	0
Lower Huron	Sycamore Bend	90	3	1	4	1	Yes	Appears to meet all requirements	539	Completed 2019	0
Lower Huron	Woods Creek North	130	4	1	5	1	Yes	Appears to meet all requirements	539	Completed 2019	0
Oakwoods	Nature Center	215	5	2	5	2	Yes	Appears to meet all requirements	685	Completed 2019	0
Stony Creek	Southdale/Go Ape Adventure	100	4	2	4	1	Yes	Appears to meet all requirements.	700	Completed 2019	0
Stony Creek	Northdale	99	4	2	4	1	Yes	Appears to meet all requirements.	700	Completed 2019	0
Stony Creek	Gladeview South	100	4	2	4	1	Yes	Appears to meet all requirements.	700	Completed 2019	0
Stony Creek	Gladeview Restroom Parking	3	2	1	1	1	Yes	Appears to meet all requirements.	700	Completed 2019	0
Stony Creek	Gladeview North	98	3	2	4	1	Yes	Appears to meet all requirements.	700	Completed 2019	0
Stony Creek	Oakgrove West	105	5	2	5	2	Yes	Appears to meet all requirements.	700	Completed 2019	0
Stony Creek	Oakgrove Restroom Parking	3	2	1	1	1	Yes	Appears to meet all requirements	700	Completed 2019	0
Stony Creek	Oakgrove North	138	5	2	5	1	Yes	Appears to meet all requirements.	700	Completed 2019	0
Stony Creek	Ridgewood East	72	4	1	3	1	Yes	Appears to mee all requirements.	700	Completed 2019	0
Stony Creek	Ridgewood West	95	4	1	4	1	Yes	Appears to meet all requirements.	700	Completed 2019	0
Stony Creek	Lakeview	101	0	0	5	1	Yes	Appears to meet all requirements	700	Completed 2019	0
Stony Creek	Osprey Lot	12	1	1	1	1	Yes	Appears to meet all requirements.	700	Completed 2019	0
Stony Creek	Nature Center	77	4	2	4	1	Yes	Appears to meet all requirements.	700	Completed 2019	0
Stony Creek	Baypoint Beach	668	14	4	14	3	Yes	Appears to meet all requirements.	700	Completed 2019	0
Stony Creek	Mt. Vernon / Boat Rental	150	5	1	5	1	Yes	Appears to meet all requirements.	700	Completed 2019	0
Stony Creek	Winter Cove North	109	5	2	5	1	Yes	Appears to meet all requirements.	700	Completed 2019	0
Stony Creek	Winter Cove South	187	6	1	6	1	Yes	Appears to meet all requirements.	700	Completed 2019	0
Stony Creek	West Branch North (East Lot)	46	3	2	2	1	Yes	Appears to meet all requirements.	700	Completed 2019	0
Stony Creek	West Branch North (West Lot)	38	3	2	2	1	Yes	Appears to meet all requirements. Recommend grouping some of the West Branch South lot totals with this lot.	700	Completed 2019	0
Stony Creek	West Branch West	54	3	2	3	1	Yes	Appears to meet all requirements.	700	Completed 2019	0
Stony Creek	West Branch East	58	3	1	3	1	Yes	Appears to meet all requirements.	700	Completed 2019	0
Stony Creek	Shore Fishing	42	2	1	2	1	Yes	Appears to meet all requirements	700	Completed 2019	0
Stony Creek	Boat Launch	266	5	2	5	2	Yes	Appears to meet all requirements	700	Completed 2019	0
Willow	Washago Pond Picnic Shelter	51	2	1	3	1	Yes	Appears to meet all requirements	593	Completed 2019	0
Willow	Willow Pool	580	12	12	12	2	Yes	Appears to meet all requirements	593	Completed 2019	0

PRIORITY 1. PRIMARY RECREATIONAL VISITOR APPROACH AND ENTRANCE AREAS

Park	Location	Total Spaces	Total # of HC Spaces	# that are Van Accessible	Required HC Spaces	Required Van Spaces	Space Meet All Requirements	Notes	Cost	Timeline	Priority Ranking
Willow	Golf Course	122	7	2	5	1	Yes	Appears to meet all requirements	593	Completed 2019	0
Willow	Golf Course Driving Range	25	1	1	1	1	Yes	Appears to meet all requirements	593	Completed 2019	0
Willow	Washago Pond Rental Facility	96	5	1	4	1	Yes	Appears to meet all requirements	593	Completed 2019	0
Willow	Fox Meadows	79	5	1	4	1	Yes	Appears to meet all requirements	593	Completed 2019	0
Willow	Big Bend 1	36	2	1	2	1	Yes	Appears to meet all requirements	593	Completed 2019	0
Willow	Big Bend North	64	2	1	3	1	Yes	Appears to meet all requirements	593	Completed 2019	0
Wolcott Mill	Farm Center Service Yard	0	0	0	0	0	Yes	An accessible space may be required. Low priority.	470	Completed 2019	0
Wolcott Mill	Farm Center	109	5	3	5	1	Yes	Appears to meet all requirements	470	Completed 2019	0
Wolcott Mill	Historic Center (authorized parking area)	10	2	1	1	1	Yes	Appears to meet all requirements	470	Completed 2019	0
Wolcott Mill	Historic Center	106	5	1	4	1	Yes	Appears to meet all requirements	470	Completed 2019	0
Wolcott Mill	Camp Rotary Activity Center	17	1	1	1	1	Yes	Appears to meet all requirements	470	Completed 2019	0
Wolcott Mill	Camp Rotary Restrooms	2	1	1	1	1	Yes	Appears to meet all requirements	470	Completed 2019	0
Wolcott Mill	Camp Rotary Picnic Shelter	17	1	1	1	1	Yes	Appears to meet all requirements	470	Completed 2019	0
Delhi	East Delhi - South Lot	184	0	0	6	1	No	Recommend grouping both parking lot totals and adding a seventh space in the southeast corner of the south lot by the aggregate service road and baseball field. 290 spaces requires 7 spaces. Leave parking space aggregate.	To be determined	2027	4
Stony Creek	Eastwood Beach	716	14	4	14	3	No	Add a crosswalk marking for access aisle adjoining accessible route. Recommend relocating a couple of spaces closer. Lot goes into overflow frequently. May want to add additional accessible spaces for these days.	To be determined	2027	4
Stony Creek	West Branch South Lot	57	0	0	3	1	No	Three accessible spaces needed. Recommend grouping parking totals with the West Branch North West Lot and West Branch North East Lot.	To be determined	2027	4
Kensington	Windfall Hill	83	4	2	4	2	Yes	Accessible route to shelter, not high priority	To be determined	2029	5
Lake Erie	Shore Fishing	16	0	0	1	1	No	An accessible space may be required. Low priority.	To be determined	2029	5
Stony Creek	Golf Course	102	4	2	5	1	No	Recommend moving the existing accessible aisle on the south side and adding one space at that end. Regrade accessible space and access aisles no steeper than 1:48 in all directions (or reconfigure with paint if there are acceptable slope/location options for accessible parking)	To be determined	2029	5

Accessibility Ranking (listed by park in order of importance based on project factors)

Rating	Description
1	Very high demand for an accessible path. Locations of facilities are appropriate, construction costs are often low, and use is very high. Potential safety concern. Recommend year 1 to 2 implementation.
2	High demand for an accessible path. Locations of facilities are appropriate. Project costs are a little more substantial and use of facility is often a little less. Potential safety concern. Recommend year 3 to 4 implementation.
3	Medium demand for an accessible path. Locations of facilities may be questionable. Project costs are more substantial and use of facility is much less. Recommend year 5 to 6 implementation.
4	Very low demand for an accessible path or project location is questionable. Access may need to wait until facility location is improved. Access is rarely needed or cost prohibited at these locations. Use of area may be extremely low. Recommend year 7 to 8 implementation.
5	Extremely low demand for accessible path or project location is extremely questionable. Access is often not needed in these locations. Recommend year 9 to 10 implementation.

PRIORITY 1. PRIMARY RECREATIONAL VISITOR APPROACH AND ENTRANCE AREAS

Park	Location	Description	Justification/Solution	Cost	Timeline	Priority Ranking2
Willow	Washago Pond South Lot	Improved access desired to soccer fields from the parking lot access drive. Culvert needed.	Access is needed along the access drive to the south lot. Wood decking is currently in place to bridge the drainage swale. Provide a surface that is firm and stable with a running slope no steeper than 5% and a cross slope not steeper than 2%, a minimum clear width of 36".	To be determined	Completed	0
Dexter-Huron	Northwest Parking Lot	Access walk desired from the west parking lot to the hike-bike trail. Could be part of the B2B trail project.	Heavily used trailhead. Worn path used as this time does not provide good access for strollers, rollerblades, etc. Provide a surface that is firm and stable with a running slope no steeper than 5% and a cross slope not steeper than 2%, a minimum clear width of 36".	To be determined	2021	1
Huron Meadow	Acorn Ridge	Accessible walks desired connecting the parking lot, picnic shelter, restrooms, and accessible playground. 470' of path needed. Accessible parking spaces should be moved closer to the shelter.	Popular area for a variety of activities. No access paths at this time. Provide a surface that is firm and stable with a running slope no steeper than 5% and a cross slope not steeper than 2%, a minimum clear width of 36".	To be determined	2021	1
Indian Springs	Shelters C, D, & E	Access walks desired to the three small rental shade structures.	Very short segments required. 70' total. Accessible tables have been ordered for these shelters. Provide a surface that is firm and stable with a running slope no steeper than 5% and a cross slope not steeper than 2%, a minimum clear width of 36".	To be determined	2021	1
Indian Springs	North Meadowlark	Improve access desired connecting the Spray 'N' Play and South Meadowlark restroom building.	Should be grouped with other access improvement projects. 280' of path required. Provide a surface that is firm and stable with a running slope no steeper than 5% and a cross slope not steeper than 2%, a minimum clear width of 36".	To be determined	2021	1
Indian Springs	North Meadowlark	Accessible walk desired connecting the parking lot, shelter, and restrooms.	Will likely become the more popular shelter when the North Martindale playground is removed. Provide a surface that is firm and stable with a running slope no steeper than 5% and a cross slope not steeper than 2%, a minimum clear width of 36".	To be determined	2021	1
Indian Springs	South Meadowlark	Accessible walk desired connecting the parking lot, shelter, and restrooms.	When the Meadowlark playground is removed this may become less popular than the North Martindale. This also requires a longer path. Provide a surface that is firm and stable with a running slope no steeper than 5% and a cross slope not steeper than 2%, a minimum clear width of 36".	To be determined	2021	1
Kensington	Boat Rental	Reconstruct accessible ramps and relocate handicap parking spaces.	One of our most used facilities in the park. Group with the connector to the hike-bike trail in the same area. Ramp needs handrail extensions at the top and bottom of the ramp that extend out at least 12" and are parallel to the ground surface. Comply with all other ramp standards.	To be determined	2021	1
Kensington	Boat Rental	Accessible walk desired linking the hike-bike trail to the boat rental facility.	One of our most used facilities in the park. Group with the handicap ramps in the same area.	To be determined	2021	1
Kensington	Maple Beach	Improved ramp access desired with 6' flares.	Reconstruct ramp as part of the Maple Beach Redevelopment. Short trail segment required.	To be determined	2021	1

Kensington	Maple Beach	Accessible path desired from the parking lot to the hike-bike trail.	Reconstruct ramp as part of the Maple Beach Redevelopment. Short trail segment required.	To be determined	2021	1
Kensington	Nature Center	Accessible walk desired to and in front of the trailhead structure.	Busy trailhead. Very small area needing aggregate.	To be determined	2021	1
Kensington	North Martindale Beach Connector Trail	Accessible walk desired connecting the North Martindale picnic area to the Beach Activity Area. 270' of walk needed to connect existing paths.	There is no access between the North Martindale shelter and Beach Activity Area at this time. One of the most rented shelters in the park.	To be determined	2021	1
Kensington	South Martindale Connector Trail	Accessible walk desired connecting the South Martindale path to the Beach Activity Area. 420' of walk needed.	Safety concern, trail outlets at main drive into Martindale Beach. Other option is to remove the South Martindale Beach path.	To be determined	2021	1
Kensington	Nature Center	Accessible walk desired connecting the hike-bike trail to the Nature Center.	Try and draw trail users to the Nature Center.	To be determined	2021	1
Kensington	North Hickory	Accessible walk desired connecting the parking lot, picnic shelter, and restroom building.	There is no access walk to the picnic shelter.	To be determined	2021	1
Kensington	West Boat Launch Finger Piers	Accessible finger piers and access to the finger piers desired at the boat launch.	Very busy launch area.	To be determined	2021	1
Kensington	Orchard	Fix asphalt opening on route greater than 1/2 inch. Fix gap in concrete of door entrance threshold	Remove this section and provide a surface that is firm and stable and gaps no wider than 1/2" and no deeper than 1/2"	To be determined	2021	1
Lake St. Clair	Golf Road Shelter	Recommend moving the parking block that limits access to 3' width. 6' minimum width required to meet universal design standards.	Easily accomplished.	To be determined	2021	1
Lake St. Clair	Daysail Shelter	Recommend moving the accessible parking spaces closer to the shelter. Requires removal of a parking bumper.	Easily accomplished.	To be determined	2021	1

Lake St. Clair	Seawall Shelter	Accessible walk desired connecting the parking lot and shelter. Recommend including with the next phase of the parking lot.	Heavily used shelter. Construction should be occurring nearby shortly.	To be determined	2021	1
Lake St. Clair	North Marina Shelter	Access Path	See Picnic Evaluatoin	To be determined	2021	1
Lake St. Clair	West Beach Shelter	Accessible walk desired connecting the shelter, parking lot, and restrooms. Recommend constructing these walks as part of a future trail project that connects the Daysail area to the Beach area.	Heavily used shelter. Trail to day sail lot is heavily used as well.	To be determined	2021	1
Lake St. Clair	Voyageur Shelter	Access Path	See Picnic Evaluatoin	To be determined	2021	1
Oakwoods	Nature Center	Improved ramp access desired. Recommend moving the spaces closer to the main walks.	6' flares required on ramps. Poor access to Nature Center at this time. 2018 MNTF Grant pursuit will provide proposed asphalt pavement repair to flatten new accessible parking area with walkway.	To be determined	2021	1
Stony Creek	Baypoint Beach	Accessible walk desired connecting the hike-bike trail and picnic shelter. Recommend including an accessible grill with projects like these.	Very short trail segment. Rented frequently. Project has already been designed.	To be determined	2021	1
Stony Creek	West Branch West	Accessible walk desired connecting the picnic shelter and restroom building. Recommend including a walk towards the West Branch East shelter across the street and roadside parking area at the same time.	Heavily used picnic area without access walks. Project has already been designed.	To be determined	2021	1
Stony Creek	Oakgrove North	Accessible walk desired connecting the shelter and restroom building.	415' section of walk needed.	To be determined	2021	1
Stony Creek	West Branch East	Accessible walk desired connecting the parking lot, shelter, and restroom building.	Recommend grouping with the West Branch West access walks.	To be determined	2021	1

Stony Creek	Winter Cove North	Accessible walk desired connecting parking lot, adjacent shelters, restroom building, and the accessible playground.	Recommend relocating the shelter so it is on the same side as the restroom building and closer to the water and playground.	To be determined	2021	1
Stony Creek	Oakgrove Playground	Accessible walk desired connecting the parking lot, restroom building, and accessible playground.	Recommend moving the playground on the same side as the shelters and restroom building.	To be determined	2021	1
Stony Creek	Boat Rental	Accessible walk to boat rental	Create a stable, firm and slip resistant accessible route to boat rental.	To be determined	2021	1
Willow	Pool Shelter	Accessible walks desired connecting the shelter, parking lot, and pool activity area.	Shelter was recently constructed. New construction must meet ADA requirements.	To be determined	2021	1
Willow	Fox Meadows	Accessible walk desired connecting the south shelter to the Pool Activity Area. 400' of walk needed.	Poor access to the Pool area at this time.	To be determined	2021	1
Willow	Fox Meadows	Accessible walk desired connecting the parking lot, north shelter, and restrooms. 300' of trail needed. Recommend including the an accessible walk to the hike-trail with this project. 190' of trail needed.	Has access to the pool but not to the restroom building or the hike-bike trail.	To be determined	2021	1
Willow	Big Bend Restrooms	Improved pavement desired at a walk near the restrooms.	Pavement needed instead of the aggregate repair that was made.	To be determined	2021	1
Willow	Indian Ridge	Accessible walks desired connecting the parking lot, restrooms, and hike-bike trail.	Vault latrines don't meet ADA requirements. This is the only lot in the area with hike-bike trail access.	44,100	2021	1
Willow	Big Bend Trail Access	Accessible walk desired from the upper roadside parking lot to the hike-bike trail. As part of the project an ADA picnic table and an ADA drinking fountain can be updated with access from the hike-bike trail. 165' of trail needed.	Short trail segment needed. Access to restrooms is far away. Drinking fountain is close to the trail.	23,100	2021	1

Willow	Big Bend Kayak Launch	Accessible walk desired connecting the parking lot, kayak launch, and an accessible picnic table. 245' of trail needed.	The kayak launch does not meet ADA requirements. Long trail segment for the amount of use.	To be determined	2021	1
Hudson Mills	Activity Center	Accessible walk desired to and in front of the nature trail trailhead.	Access should be provided to all trailheads.	To be determined	2023	2
Huron Meadows	Sunset Ridge	Accessible walk desire to and in front of the new trailhead. Recommend aggregate surface at this time.	Improved access desired. Very small project.	To be determined	2023	2
Huron Meadows	Cedar Ridge	Recommend paving the accessible parking spaces that are there. Spaces and signs do not align with the paved access path.	Area is used for a variety of year-round activities. Busier than you might expect.	To be determined	2023	2
Lake Erie	Marshlands Museum - Eagle Enclosure	Accessible walk desired connecting the parking lot, eagle enclosure, boat house, and future trailhead.	Nature trails are flat and can be made accessible fairly easily.	26,000	2023	2
Lake Erie	Cove Point	Accessible walks desire to the restrooms.	Adjoin access aisle to accessible route (create accessible route). Main entrance needs to be leveled.	10,600	2023	2
Lake Erie	Marina Point	Improved access desired. Recommend widening the walk from the lot to 6' minimum width to meet universal design standards.	3' walk provides access at this time. Regrade cross slope to 1:48 max	6,000	2023	2
Lower Huron	Sycamore Bend	Improved access desired to the picnic area. A drainage swale limits access from much of the parking lot. Culvert(s) needed.	There is a safety concern with visitors having to cross the deep swale at the south end where there is poor access.	To be determined	2023	2
Lower Huron	Woods Creek Ramps	Improved ramp access desired at two locations.	6' flares required on ramps. Fix concrete	To be determined	2023	2
Stony Creek	Gladeview North	Accessible walk desired connecting the shelter and restroom building.	Has an existing path to the shelter, but no path to the restroom building. Heavily used by disc golfers.	To be determined	2023	2
Dexter-Huron	East Shelter	Access walk desired connecting the East Picnic Shelter to parking, restrooms, and the hike-bike trail. Include as part of the B2B trail project.	There are no access walks to the East Picnic Shelter from either of the east parking lots.	To be determined	2025	3

Dexter-Huron	West Shelter	Access walk desired connecting one of the west parking lots and the West Picnic Shelter. Shelter has access to the restroom building.	Oldest shelter in the park system. May need to be moved because of the Natural Rivers Area when it is time to replace.	To be determined	2025	3
Hudson Mills	Activity Center	Accessible walk desired connecting the shelter, parking, and Activity Center restrooms.	Other projects have been discussed that may impact this path. These include a spray pad and new restroom building. Adjust activity center door closer so it meets 5 seconds to close standard. Secure carpet at door entrance at edges.	To be determined	2025	3
Kensington	Farm Center	Improved access desired at the Farm Center. Walks exceed 5% in many locations. Recommend signing the accessible routes within the facility.	Very busy part of the park. The area should have accessible facilities.	To be determined	2025	3
Kensington	South Martindale Drop Off Area	Accessible ramp desired at the drop off area to the beach.	Other ramps are provided nearby but not at the preferred location where the walks split.	To be determined	2025	3
Kensington	South Martindale Shelter	Accessible walks desired connecting the picnic shelter and restrooms.	No access walks at this time. Reconsider restroom building location to minimize walks and increase use of facilities.	To be determined	2025	3
Kensington	West Playfield	Accessible walks desired connecting the parking lot, restrooms, remote shelter, and remote accessible playground.	No access walks at this time. Consider relocating shelter and playground closer to a lot in the future.	To be determined	2025	3
Kensington	East Boat Launch Lower Lot	Accessible boat launch has accessible path; parking lot lacks accessible path to fishing piers; regrade/redesign ramp from parking lot to fishing pier/sailboat slips		To be determined	2025	3
Kensington	Possum Hollow Restroom	Bathroom entrance needs concrete repair.	Remove this section and provide a surface that is firm and stable	To be determined	2025	3

Lake Erie	Great Wave	Accessible walks desired connecting both shelters to the existing porta johns. Recommend relocating the porta-johns to an easily accessible location from both shelters. May require an additional porta-john, one for each shelter.	Recommend moving one of the shelters in the future and locating it on the same side with access to a new restroom building.	14,700	2025	3
Lake St. Clair	Lot D	The path to warming shelter is not accessible	Remove this section and provide a surface that is firm and stable	To be determined	2025	3
Lower Huron	South Fishing Bike Rack	Accessible walk desired to the bike rack.	Access to small items like these still need access routes.	To be determined	2025	3
Oakwoods	Cedar Knoll	Accessible walk desired connecting the parking lot and restrooms. Access to a kayak launch should be considered.	Little used picnic area. Vault latrines are not accessible.	85,905	2025	3
Stony Creek	Mt. Vernon / Boat Rental	Accessible walk desired connecting the boat rental facility and restrooms. Recommend constructing an access path to the Voyageur Canoe Launch at the same time. Need to determine plans for this project.	Our highest used area without an accessible walk. There is uncertainty on the plans and timing of its replacement.	To be determined	2025	3
Stony Creek	Winter Cove South	Accessible walk desired connecting the parking lot, adjacent shelters, and the accessible playground.	Recommend grouping this project with the access walks to Winter Cove North. Remove this section and provide a surface that is firm and stable	To be determined	2025	3
Willow	Flintwoods Fountain	Accessible drinking fountain desired. Fountain along the paved walk doesn't meet ADA requirements.	Replacing drinking fountains along paved walks can be accomplished easily compared to those out in turf areas.	16,000	2025	3
Hudson Mills	Pine View	Accessible walk desired connecting the parking lot and hike-bike trail.	Short segment of trail needed. Access path will provide improved access for runners, strollers, in-line skaters, etc.	To be determined	2027	4

Kensington	West Boat Launch	Accessible walk desired connecting the picnic shelter and restrooms. Recommend modifying walk alignments around the restroom building and improving access to the hike-bike trail near the restrooms at the same time.	Heavily used area. Some topography issues. 2018 MNTF Grant pursuit would include proposed 6' width concrete walks and barrier free parking connecting to proposed kayak launch, vault latrine, accessible table and grill, and existing picnic shelter.	To be determined	2027	4
Kensington	Living History Area	Accessible walks desired to and around the Living History Area.	Popular area for a variety of activities. Area continues to grow. No access at this time.	To be determined	2027	4
Kensington	Shore Fishing	Accessible walks desired connecting the parking lot and restrooms. Access to the kayak launch area should be considered.	No access walks or accessible parking at this time.	To be determined	2027	4
Lake St. Clair	Nature Center Drop Off Area	Ramped access desired from the drop off area.	Ramps are located near the accessible parking spaces but not at the drop off area in front of the building.	To be determined	2027	4
Stony Creek	West Branch North	Accessible walk desired connecting the parking lot, restrooms, and basketball court.	Recommend redevelopment of this picnic area. Shelter relocation and lot reconfiguration can reduce the amount of walks needed and improve safety and circulation in the area. More parking may be desired for the mountain biking trails if redeveloped.	To be determined	2027	4
Stony Creek	Baypoint Beach	Accessible walk desired connecting the parking lot, restrooms, and the basketball court.	Plans for the redevelopment of the beach show the basketball court remaining.	To be determined	2027	4
Willow	Washago Pond Center Lot	Improved access desired to the soccer fields when wet. Culvert needed.	South lot is closer and used more frequently for soccer field access. Provide a surface that is firm and stable	To be determined	2027	4
Wolcott Mill	Camp Rotary	Accessible walks desired connecting an accessible camp site, fire ring, and restrooms.	Accessible camp sites may be desired.	To be determined	2027	4
Dexter-Huron	Northeast Parking Lot / Baseball Field	Improved access desired to the baseball field. Culvert needed.	Current field access requires walking around a wet drainage swale. There has been some discussion about removing the baseball field. The field was removed from recent roadside signs.	To be determined	2029	5
Hudson Mills	Golf Course	Improved ramp access desires in two locations along with striping to ensure ramps can be accessed.	Ramps are not built to current standards. 6' flares required. Regrade curb ramp or move closer.	To be determined	2029	5
Hudson Mills	Activity Center	Accessible walk desired to the shuffleboard courts.	Very short connector required. Fairly new court. Very little use.	To be determined	2029	5

Hudson Mills	Activity Center	Accessible walk desired connecting the paved path and basketball court.	Court is remote. Consider a new location and a multipurpose tennis, pickleball, and basketball court. There has been some discussion about removing the court. Provide a surface that is firm and stable with a running slope no steeper than 5% and a cross slope not steeper than 2%, a minimum clear width of 36"	To be determined	2029	5
Hudson Mills	Pine View	Accessible walks desired connecting the parking lot, picnic shelter, and restrooms. Recommend grouping with the access path to the hike-bike trail. Consider eliminating shelter and need for long paved park road. Recommend relocating the shelter to the Activity Center with a new accessible restroom building.	One of the least rented shelters in the park. Provide a surface that is firm and stable with a running slope no steeper than 5% and a cross slope not steeper than 2%, a minimum clear width of 36"	To be determined	2029	5
Hudson Mills	Activity Center	Accessible walk desired connecting the paved path, tennis courts, and drinking fountain.	Courts are in disrepair and closed at this time. Accessible drinking fountain needed. Provide a surface that is firm and stable with a running slope no steeper than 5% and a cross slope not steeper than 2%, a minimum clear width of 36"	To be determined	2029	5
Hudson Mills	Maintenance Yard	Accessible ramp desired from the employee parking lot.	An accessible parking space may be required.	To be determined	2029	5
Hudson Mills	Activity Center	Accessible walk desired to the playground drinking fountain.	Drinking fountain is not an accessible fountain. Relocation of fountain recommended. Provide a surface that is firm and stable with a running slope no steeper than 5% and a cross slope not steeper than 2%, a minimum clear width of 36"	To be determined	2029	5
Hudson Mills	Group Camp	Accessible walks desired connecting parking, restrooms, fire ring, and a campsite.	Recommend having one accessible camp site. Low priority.	To be determined	2029	5
Hudson Mills	Oak Meadows	Accessible walk desired connecting the parking lot and restrooms.	Vault latrines are very remote and not accessible. Used primarily by disc golfers. The shelter in this area was removed. A restroom building could be consider in the future as part of an athletic field complex.	To be determined	2029	5
Hudson Mills	Fishing Site	Accessible route desired	Recommend having one accessible parking space and route. Low priority.	To be determined	2029	5
Huron Meadow	Golf Course	Improved ramp access desired. 6' flares required on ramps. Recommend adding a walk in front of vehicles to avoid access route in parking lot. Ramp could be moved closer to the accessible spaces.	Improved access desired.	To be determined	2029	5

Indian Springs	Golf Course	Improved ramp access desired.	6' flares required on ramps.	To be determined	2029	5
Kensington	Mitten Bay	Accessible walks desired connecting the parking lot, restrooms, and walks around the marina.	Some topography issues and lengthy walk needed. Provide a surface that is firm and stable with a running slope no steeper than 5% and a cross slope not steeper than 2%, a minimum clear width of 36"	To be determined	2029	5
Kensington	South Hickory	Accessible walks desired connecting the parking lot, picnic shelter, and restrooms.	No access walks at this time. Topography makes this difficult. Consider relocating shelter.	To be determined	2029	5
Kensington	Baywoods	Accessible walk desired connecting the restroom building and picnic shelter.	No access walk at this time. Topography makes this difficult. Consider relocating shelter in the future.	To be determined	2029	5
Kensington	Park Office	Improved ramp access desired.	6' flares required on ramps.	To be determined	2029	5
Kensington	Boat Rental	Accessible walks desired connecting the parking lot, boat rental building, and kayak launch area.	Topography issues and there is not an accessible launch at this time.	To be determined	2029	5
Lake St. Clair	Boat Launch	Accessible walk desired connecting the parking lot and excursion boat pick-up area on the south side.	It is unclear if the excursion boat pick-up location has been moved to a different location. Consider moving to a location that is already accessible. Provide a surface that is firm and stable with a running slope no steeper than 5% and a cross slope not steeper than 2%, a minimum clear width of 36"	To be determined	2029	5
Lake St. Clair	Nature Center	Accessible walk desired to the fire pit location.	Not used frequently. Provide a surface that is firm and stable with a running slope no steeper than 5% and a cross slope not steeper than 2%, a minimum clear width of 36"	To be determined	2029	5
Lower Huron	Hawthorn Glade / Ellwoods	Accessible walks desired connecting restrooms, parking, the accessible playground, accessible drinking fountain, the North and South Shelter, and Turtle Cove.	These picnic areas are used heavily and provide access to Turtle Cove without having to cross a road. Recommend locating the South shelter closer to parking. Access walks can be minimized in the future with different shelter and restroom locations. This is one of the few restrooms in the park system without accessible walks.	To be determined	2029	5
Lower Huron	Tulip Tree	Accessible walk desired connecting the shelter, restrooms, and accessible drinking fountain.	The shelter and restroom building are on opposite sides of the road. Recommend locating both on the same side in the future or removing the shelter if camping were ever to expand. Consider removing the drinking fountain or relocating along a walk.	To be determined	2029	5
Stony Creek	West Branch North	Accessible walk desired connecting the shelter and restrooms.	Recommend redevelopment of this picnic area. Perhaps move the shelter and west lot. Double the size of the east lot so all facilities are located on the same side of a lot.	To be determined	2029	5
Stony Creek	Southdale	Accessible walk desired connecting the parking lot, restroom building, and shelter.	Future plans uncertain with Go Ape, however, popular picnic area.	To be determined	2029	5

Stony Creek	Oakgrove West	Accessible walk desired connecting the parking lot, picnic shelter, and restroom building.	Topography issues. Recommend relocating shelter in the future.	To be determined	2029	5
Stony Creek	Southdale	Accessible walk desired connecting the parking lot, restrooms, and basketball court.	Recommend relocating court to make it closer in the future.	To be determined	2029	5
Stony Creek	Northdale	Accessible walk desired connecting the parking lot, restrooms, and basketball court.	85' section needed between the parking lot and court. Much longer if access is provided to the restroom building.	To be determined	2029	5
Stony Creek	Gladeview South	Accessible walk desired connecting the shelter and restroom building.	Little used picnic shelter. Topography issues. Recommend relocating shelter to another picnic area or removing.	To be determined	2029	5
Stony Creek	Mt. Vernon	Accessible walk desired connecting the parking lot, restrooms, and picnic shelter.	Topography issues. Recommend relocating the shelter to an accessible location in the future. Perhaps where the boat rental building is located if that facility is moved to Baypoint Beach.	To be determined	2029	5
Stony Creek	Golf Starter Building	Accessible walk from parking spaces needs regrading	Regrade accessible spaces and access aisles no steeper than 1:48 in all directions (or reconfigure with paint if there are acceptable slope/location options for accessible parking.	To be determined	2029	5
Willow	Washago Pond South Lot	Improved access desired to soccer fields when wet. Culverts needed. Improved access is also desired to the hike-bike trail. Recommend combing both projects.	Soccer field access was discussed earlier this year as a project staff could do. Provide a surface that is firm and stable with a running slope no steeper than 5% and a cross slope not steeper than 2%, a minimum clear width of 36"	To be determined	2029	5
Willow	Golf Course	5 accessible signs missing. 2 van signs missing. Curb ramp threshold steeper than 1:12	Regrade curb ramp no steeper than 1:12.	To be determined	2029	5
Willow	Chestnut Restrooms	Accessible walk desired connecting the Chestnut East shelter to one of the restroom buildings. 440' of walk needed.	Consider moving out of the floodplain to another area that already has a restroom. Co-locate restrooms, playgrounds and shelters on the same side of a lot. Consider eliminating this shelter.	To be determined	2029	5
Willow	Elder Creek Restrooms	Remove vault latrines	Vault latrines don't meet ADA requirements. Accessible restrooms are located close by. Consider removing these restrooms in the future.	To be determined	2029	5
Willow	Acorn Knoll Restrooms	Accessible walks desired connecting the parking lot and restrooms.	Other picnic areas are more popular. Vault latrines don't meet ADA requirements.	To be determined	2029	5
Willow	Dance Pavilion	60" turning radius required at top of ramp.	Ramp design is not perfect but works. Low priority.	To be determined	2029	5

Wolcott Mill	Camp Rotary	Accessible walks desired to the spectator viewing areas at the 4-H arenas.	Used infrequently. Provide a surface that is firm and stable with a running slope no steeper than 5% and a cross slope not steeper than 2%, a minimum clear width of 36"	To be determined	2029	5
Wolcott Mill	Camp Rotary	Accessible walk desired connecting the parking lot, Camp Rotary shelter, and restroom building.	Used infrequently. 375' of walk needed.	To be determined	2029	5
Wolcott Mill	Historic Center	Accessibility issues based on topography	Topography issues at Historic Center. Two paths diverge prior to Historic Center. Directional sign to the Mill Race paved approach exceeds grade requirements and cross slopes. For ADA use ramp, with directional sign to bathroom.	To be determined	2029	5

Amenities ranked 1 through 32 (1-6 implemented by year 2, 7-12 implemented by year 4, 13-18 implemented by year 6, 19-24 implemented by year 8, and 25-31 implemented by year 10)	Generalized Priority Ranking
Accessible Parking	1
Accessible Routes and Ramps (Paved)	2
Accessible Door Openers / Knobs	3
Accessible Restrooms	4
Accessible Port-a-John Facilities	5
Accessible Picnic Shelters	6
Accessible Tables	7
Accessible Trails (Aggregate)	8
Accessible Playgrounds	9
Accessible Pools / Spray Pads	10
Accessible Service Counter Window	11
Accessible Drinking Fountains/Water Refill Stations	12
Accessible Coat Racks / Hangers in Restrooms	13
Accessible Fishing Dock	14
Accessible Golf Carts	15
Accessible Hayrides	16
Accessible Boat Ramps	17
Accessible Marina Slips	18
Accessible Waterfronts / Beaches	19
Accessible Livery Facilities	20
Accessible Grills	21
Accessible Kayak Launches	22
Accessible Work Environments	23
Accessible Camp Sites / Group Camp Sites	24
Accessible Equestrian Staging Areas	25
Accessible Shuffleboard Courts	26
Accessible Basketball Courts	27
Accessible Baseball Fields	28
Accessible Soccer Fields	29
Accessible Bike Racks	30
Accessible Sand Volleyball Courts	31
Accessible Disc Golf Facilities	32
Prioritization for placement of an accessible drinking fountain, table, etc. will often be based on the areas frequency of use. The following areas are considered priority areas with generalized priority ranking following implementation years 1-10+	Generalized Priority Ranking
Hike-Bike Trail	1
Activity Center / Central Plaza	1
Nature Center, Museum, Historic Center, Environmental Education Center	2
Farm Center	2
Beach	3
Pool / Spray Pad	3
Heavily Used Rental Shelters	4
Boat Rental Facility	4
Canoe / Kayak Livery	5
Food Venue	5
Golf Course	5
Venue (equity ranking considered in priority ranking)	Equity Ranking Scale
Free - Broad Based Recreation	1
Some Cost Associated - Purchase of Equipment	2
Small Fee Associated - \$2-\$24	3
Large Cost Associated - Purchase of a Boat / Horse	4
Large Fee Associated - \$25 plus - Exclusive Club, Narrowly Focused	5
Venue (equity ranking considered in priority ranking)	Equity Ranking
Nature Center	1
Farm Center	1
Picnic Areas	1
Running and Walking Trails	1
Beach	1
Spray Pad	1
Restrooms	1
Mountain Biking Trails	2
Field Sports and Courts	2
Fishing Docks	2
Picnic Shelter	2
Cross Country Skiing	3
Pool	3
Camping	3
Boat Rental	3
Disc Golf	3
Adventure Golf	3
Group Camp	3
Equestrian Facilities	4
Boat Launch	4
Canoe / Kayak Livery	4
High Ropes Course	4
Golf	5
Marina	5

PRIORITY 2. ACCESS TO GOODS AND SERVICES RECREATIONAL VISITOR AREAS (Renovations, Replacements, and Additions)

Park	Location	Description	Justification/Solution	Cost	Timeline	Priority Ranking
Wolcott Mill	Camp Rotary Activity Center	Counter service areas in compliance	Meets ADA requirements.	Not available	Completed	0
Hudson Mills	Activity Center	Door closer needs adjusting, carpets need to be secured	Popular facility for events. Provide a mat with a heavier backing or tape the mat to the floor. Add closer.	To be determined	2021	1
Indian Springs	EDC	Lower signs and raise letters/braille. Clear floor space for light switches not met. Service counters for both main counter and banquet room exceed height limit	Does not meet requirements.	To be determined	2021	1
Kensington	Nature Center	Nature Center needs minor ADA improvements.	Clear floor space for light switches, door knobs	To be determined	2021	1
Lake St. Clair	Nature Center	Restrooms need accessibility improvements, building entrance mat needs to be secured, clear floor space to light switches needed, service counter higher than 36", fish tank and display obstructing counter clear floor space	Expand restrooms into interpretive area. Other improvements needed for ADA. Provide a mat with a heavier backing or tape the mat to the floor.	To be determined	2021	1
Oakwoods	Nature Center	door handles need new hardware, garbage bin within light switch clear floor space, service counter exceeds height max.	Does not meet requirements. MNTF Grant currently being pursued.	To be determined	2021	1
Lake Erie	Museum	Goods and services need accessibility improvements	Ramp appears to not meet standards. Sign for classroom does not meet standards, update sign. Service counter above 36 inches.	To be determined	2023	2
Lake St. Clair	Par-3 and Group Rental Shelter	Accessible picnic unit for this shelter desired.	Not in compliance with ADA	To be determined	2023	2
Willow	Willow Pond Rental	Hardware does not meet height requirements, carpet not secured, service counter exceeds height max.	Does not meet requirements. Provide a mat with a heavier backing or tape the mat to the floor. Provide a section of counter that is 28 inches to 36 inches and is at least 24 inches long in alterations.	To be determined	2023	2
Wolcott Mill	Farm Center/Office	Goods and services needed.	Signs designating permanent rooms do not meet standards. Front approach to interior rooms and light switches for public do not meet standards. Service counter does not meet 36 inch height maximum. Secure carpets.	To be determined	2023	2
Kensington	Boat Rental	Service Counter, Signs	Does not meet requirements.	To be determined	2025	3
Lake St. Clair	Point Walk Drinking Fountains	Accessible drinking fountains desired. Wider walks needed along with new fountains.	Paved walks lead to drinking fountains that are not accessible.	To be determined	2025	3
Lower Huron	Turtle Cove	Ramps, signs, and service counters.	Does not meet requirements.	To be determined	2025	3
Stony Creek	Eastwood Beach	Service Counters for slide area and food area	Does not meet requirements. Provide a section of counter that is 28 inches to 36 inches and is at least 24 inches long in	To be determined	2025	3
Stony Creek	Boat Launch Building	Signs, Service Counter	Does not meet requirements. Adjust signs and provide a section of counter that is 28 inches to 36 inches and is at least 24 inches long in	To be determined	2027	4
Willow	Food Bar	Seating area, service counter.	Does not meet requirements. Provide a section of counter that is 28 inches to 36 inches and is at least 24 inches long in	To be determined	2027	4
Huron Meadows	Golf Starter Building	Service Counter	Does not meet requirements. Provide a section of counter that is 28 inches to 36 inches and is at least 24 inches long in	To be determined	2029	5
Indian Springs	Golf Starter Building	Service Counter	Does not meet requirements. Provide a section of counter that is 28 inches to 36 inches and is at least 24 inches long in	To be determined	2029	5
Lake Erie	Golf Course	Goods and services accessibility improvements	Appears to meet all requirements	Not available	Completed	0
Lake Erie	Food Bar	Goods and services accessibility improvements	Service counter above 36 inches. provide a section of counter that is 28 inches to 36 inches and is at least 24 inches long in	To be determined	2029	5
Lake Erie	Marina Building	Goods and services accessibility improvements.	Interior doors do not meet threshold vertical height limit. Carpet is not secured along edges. Move garbage can from obstructing light switch. Service counter is higher than 36 inches.	To be determined	2029	5
Stony Creek	Golf Course Starter Building	Service Counter	Does not meet requirements. Provide a section of counter that is 28 inches to 36 inches and is at least 24 inches long in alterations.	To be determined	2029	5

Willow	Golf Course Starter Building	Carpets not secure	Does not meet requirements. Provide a mat with a heavier backing or tape the mat to the floor.	150	2029	5

PRIORITY 3. RESTROOMS THAT SUPPORT PRIMARY RECREATIONAL VISITOR AREAS (Renovations, Replacements, and Additions)

Park	Location	Description	Justification/Solution	Cost	Timeline	Park Ranking2
Oakwoods	Nature Center	Restrooms need accessibility improvements	Signs to accessible location, adjust sign height, womens bathroom does not meet front approach standards, mirror and counter exceeds height limit, grab bars	To be determined	2021	1
Indian Springs	EDC	Restrooms need accessibility improvements	Grab bar adjustment. Provide a side grab bar a minimum of 42" long and a maximum of 12" from th corner. The grab bar should be mounted 33" to 36" to the top of the grab bar. Stall door needs closer and door pull	To be determined	2021	1
Kensington	Farm Center	Restroom building needed.	Popular area used for many activities	To be determined	2021	1
Kensington	Nature Center	Restrooms need accessibility improvements. Recently renovated but not to ADA standards.	Sign not on latch side, change door swing and latch side of outside door to bathrooms, change door swing but not latch side of inside door of bathrooms. Mirror greater than 40 inches. Soap dispenser greater than 44 inches. Centerline of water closet exceeds 16-18 inches. Clearance of stall closet not met. Grab bar adjustments, door pulls needed for stalls.	To be determined	2021	1
Lake Erie	Museum	Restrooms need accessibility improvements	Alter toilet room for clear floor space. Lower lavatory mirror.	To be determined	2021	1
Lake St. Clair	Nature Center	Restroom door needs threshold needs to be replaced, women counter surface exceeds height compliance, lavatory pipes need insulating, toilet water closet needs toilet or partition moved, water closet needs altering for clearance width, grab bars need relocating if constructed after 2012, flush control and toilet paper dispenser (if constructed after 2012) need to move, door handles need door pulls if constructed after 2012	Expand restrooms into interpretive area. ADA standards. Replace threshold for a smooth transition. Remount the counter in the womens restroom no higher than 34". Relocate the toilet with a centerline 16" to 18" from the wall with flush control on open side and remount the toilet paper dispenser minimum 7" to a maximum of 9" in front of the toilet, no lower than 15", no higher than 48" and do not mount behind side grab bar. Provide a side grab bar a minimum of 42" long and a maximum of 12" from th corner. The grab bar should be mounted 33" to 36" to the top of the grab bar.	To be determined	2021	1
Delhi	West Delhi	One of the last remaining old style pit toilets in the park system. Consider moving closer to the parking lot and kayak launch / take-out.	Popular area for paddlers.	To be determined	2023	2
Hudson Mills	B2B Trail / Skips	Restroom building needed.	Consider adding a facility that can be used by Skips users as well as hike-bike trail users.	To be determined	2023	2
Huron Meadows	Sunset Ridge	Restrooms need accessibility improvements	Front approach entrance does not meet 18" maneuvering clearance, adjust coat hook and grab bars, door needs closer and handles.	To be determined	2023	2
Lower Huron	North Fishing Site	One of the last remaining old style pit toilets in the park system.	Heavily used facility without accessible facilities. Use of this area will increase when the parking lot is expanded. Frequent flooding results in river pollution. Proposed new ADA vault toilets with DNR grant currently being pursued.	To be determined	2023	2
Lower Huron	South Fishing Site	Restroom building needed.	Popular trailhead, fishing, and kayak launch site. No facilities at this time. Difficult to justify for such a small parking lot.	To be determined	2023	2
Willow	Elder Creek	One of the last remaining old style pit toilets in the park system.	Recommend removing. Flush restrooms are available between the two parking lots.	To be determined	2023	2
Willow	Acorn Knoll	One of the last remaining old style pit toilets in the park system. Consider moving to the start of the disc golf course or adjusting the course so it starts from a paved lot closer to the restrooms.	Popular disc golf and picnic area.	To be determined	2023	2
Willow	Indian Ridge	One of the last remaining old style pit toilets in the park system.	Consider removing this picnic area. Lot's of infrastructure for the amount of activities in the area / use of the area.	To be determined	2023	2
Wolcott Mill	North Branch Trails	Restrooms needed.	Have discussed adding a prefab restroom building. No restrooms at this time.	To be determined	2023	2

Wolcott Mill	Farm Center/Office	Restroom renovations needed.	Accessible route greater than 5% and less than 8%, follow ramp standards or re-grade. Lower signs, door closer, lower mirrors, coat hooks, stall front approach and width not in compliance.	To be determined	2023	2
Hudson Mills	Rapids View	One of the last remaining old style pit toilets in the park system.	Flush restrooms available 800' away located at the trailhead. A 20 car lot makes it difficult to justify a restroom building. Trust Fund grant being pursued.	To be determined	2025	3
Dexter-Huron	East Dexter-Huron Comfort Station	Restrooms need accessibility improvements	Lavatory insulation, Door handles and closer needed.	To be determined	2025	3
Indian Springs	Meadowlark	Restrooms need accessibility improvements	Toilet needs moving, front approach to stall does not meet standard, door not self closing, stall width needs widening.	To be determined	2025	3
Huron Meadows	Cedar Ridge	Restrooms need accessibility improvements	Grab bar adjustment, stall door needs closer and door pull	To be determined	2025	3
Hudson Mills	Pine View	One of the last remaining old style pit toilets in the park system.	Consider eliminating / relocating this picnic area closer to the Activity Building.	To be determined	2025	3
Kensington	Equestrian Staging	Restroom building needed. Locate close to hike-bike trail.	Restroom will serve two user groups. Water needed for horses. None at this time.	To be determined	2025	3
Kensington	Possom Hollow	Restroom renovations needed.	install tactile sign in proper location, remove front approach obstructions, concrete work to level threshold, insulation for pipes, adjust hand dryer, alter compartment for 60" clearance, install grab bars, move flush control.	To be determined	2025	3
Kensington	Playfield	One of the last remaining old style pit toilets in the park system.	Consider eliminating because of proximity to existing flush restrooms or relocate so facilities are spread out.	To be determined	2025	3
Kensington	East Boat Launch	One of the last remaining old style pit toilets in the park system. Consider replacing with a Pre-Fab Restroom Building. Access walks to existing restrooms may allow these to be removed.	Consider relocating shelter closer to restrooms and eliminating pit toilets.	To be determined	2025	3
Kensington	Boat Rental	Restroom renovations needed.	Women's front approach, coat hook and womens toilet partition, men's toilet compartment needs altering.	To be determined	2025	3
Kensington	Orchard Restroom	Restroom renovations needed.	Relocate signs, lower mirrors, alter compartment for 60" width in stalls, mens doe not have 12" clearance between grab bar and projecting object above, install rear grab bar, move flush control or reconfigure water closet. Remove obstructions to front approach.	To be determined	2025	3
Lake Erie	Cove Point	Restrooms need accessibility improvements	Sign needs to be mounted on latch side. Front approach entrance needs to meet maneuvering clearance. Insulate pipes. Grab bar relocation and space requirements if constructed before 2012. Move flush control. Add closer to stall door. Add door pulls if constructed after 2012.	To be determined	2025	3
Lake Erie	Boat Launch	Restrooms need accessibility improvements.	Relocate sign to meet standards, entrance door hardware replacement and adjust closer. Grab bar space requirements need relocating. Move flush control, along with stall door handles and closer added. 2018 MNTF Grant pursuit would include these improvements if awarded.	To be determined	2025	3
Lake St. Clair	Grill Restrooms	Restrooms need accessibility improvements. Access to building was recently improved. Accessible route >5%, mens stall door needs closer, door pulls on both sides, toilet paper dispenser too close	Closest restroom facility to the recently updated playground.	To be determined	2025	3
Oakwoods	Cedar Knoll	One of the last remaining old style pit toilets in the park system.	Little used picnic area.	To be determined	2025	3
Stony Creek	Trolley Trails	Restrooms needed. Consider a Pre-Fab Restroom Building.	Area has expanded as a winter use area and does not have restrooms.	To be determined	2025	3
Stony Creek	Inwood Trails	Restroom building needed.	Have discussed adding a prefab restroom building. No restrooms at this time.	To be determined	2025	3
Stony Creek	Shore Fishing	One of the last remaining old style pit toilets in the park system. Consider repacing with a Pre-Fab Restroom Building.	Consider replacing with porta-john based on use.	To be determined	2025	3
Delhi	Skips	Restroom building needed.	Something needs to be done at this heavily used facility.	To be determined	2027	4
Kensington	Mitten Bay	One of the last remaining old style pit toilets in the park system. Consider replacing with a Pre-Fab Restroom Building.	Consider improving facilities for boaters.	To be determined	2027	4

Kensington	Shore Fishing	One of the last remaining old style pit toilets in the park system. Consider replacing with a Pre-Fab Restroom.	Consider improving facilities for fisherman and those launching kayaks.	To be determined	2027	4
Lake Erie	Marina Building	Restrooms need accessibility improvements.	Signs need relocating and text revised, new door hardware and adjust closer, alter toilet room, insulate pipes, lower counter, move toilet, grab bar relocation, toilet paper dispenser relocate.	To be determined	2027	4
Lake Erie	Food Bar	Restrooms need accessibility improvements	Accessible route vertical threshold exceeds standard. Relocate sign. Womens does not meet clear floor space standard. Fix coat hook, move toilet and grab bar. Appears toilet dispensers need relocating and womans front approach to stall needs reconfiguring along with door pulls added. Both compartments need to be widened.	To be determined	2027	4
Hudson Mills	Disc Golf Course	One of the last remaining old style pit toilets in the park system.	Disc golf course is heavily used. Consider providing an accessible restroom with a pathway surface that is firm and stable with a running slope no steeper than 5% and a cross slope not steeper than 2%, a minimum clear width of 36".	To be determined	2029	5
Hudson Mills	Activity Center	Restrooms need accessibility improvements.	Difficult project. May need a new restroom building for the Activity Area.	To be determined	2029	5
Hudson Mills	Group Camp	Three restrooms currently located in the Group Camp.	Suggest locating one to the north where it is more rustic and where it can be used by Canoe Campers and Group Camp users.	To be determined	2029	5
Indian Springs	Golf Starter Building	Restrooms need accessibility improvements	Sign relocation, door knob replacement and closer, mens privacy wall, coat hooks, move toilet, grab bars	To be determined	2029	5
Kensington	Disc Golf Course	Restroom building needed.	Consider adding restrooms for Disc Golf Users. Course is being expanded to 36 holes and only has porta-johns.	To be determined	2029	5
Kensington	Group Camp	Five restrooms currently located in the Group Camp.	Consider replacing with one or two Pre-Fab Restroom Buildings. Consider locating one on the west side of the river that can be used by multiple sites.	To be determined	2029	5
Kensington	Park Office	Restrooms need accessibility improvements.	Does not meet clear floor space in bathroom. Coat hook needs adjusting. Mens lavatory does not meet clear floor space. Pipes need insulating. Soap dispenser needs adjusting. Water closet does not meet clearance width. Stall door width not met and door pulls.	To be determined	2029	5
Lake Erie	Golf Course	Restrooms need accessibility improvements	Relocate sign to meet standards. Toilet rooms do not meet clear floor space standard. Adjust soap dispenser, grab bar, and toilet roll dispenser. Add door pulls and womens stall door needs closer.	To be determined	2029	5
Lake St. Clair	North Marina	Restrooms / Shower Facilities need accessibility improvements.	Has another shower building as an option.	To be determined	2029	5
Huron Meadows	Golf Starter Building	Restroom renovations needed.	Sign needs to be mounted on latch side and lowered in height, front approach not in compliance, threshold exceeds limit, lavatory needs insulation, move toilet, grab bars, stall width needs widening.	To be determined	2029	5
Wolcott Mill	Camp Rotary	Restroom renovations needed.	Accessible route greater than 5% and less than 8%, follow ramp standards or re-grade. Lower signs, door closer, lower mirrors, coat hooks, stall front approach and width not in compliance.	To be determined	2029	5
Wolcott Mill	Camp Rotary Activity Center Restrooms	Restroom renovations needed.	Adjust closer, mens toilet and womens flush control relocated, womens stall widened, mens front approach does not meet 60" depth, door not self-closing, missing handle.	To be determined	2029	5

PRIORITY 4. SECONDARY RECREATIONAL VISITOR APPROACH AND ENTRANCE AREAS

Park	Location	Total Spaces	Total # of HC Spaces	# that are Van Accessible	Required HC Spaces	Required Van Spaces	Space Meet All Requirements	Notes/Solution	Cost	Timeline	Priority Ranking
Hudson Mills	Rapids View	30	2	1	2	1	No	Appears to meet requirements	Not available	Completed 2019	0
Indian Springs	Park Office	76	4	4	4	1	Yes	Appears to meet all requirements.	Not available	Completed 2018?	0
Kensington	Island Road North Lot	40	2	2	2	1	Yes	Appears to meet all requirements.	1,040	Completed 2019	0
Lake Erie	Park Office Visitor Lot	26	4	1	2	1	Yes	Appears to meet all the requirements	673	Completed 2019	0
Lower Huron	Ellwoods Roadside North	11	0	0	1	1	Yes	Group with the main Ellwoods North lot	539	Completed 2019	0
Lower Huron	Ellwoods Roadside South	10	0	0	1	1	Yes	Group with the main Ellwoods North lot	539	Completed 2019	0
Lower Huron	Group Camp North	79	3	1	3	1	Yes	Appears to meet all requirements	539	Completed 2019	0
Lower Huron	Group Camp Roadside Lot	20	0	0	1	1	Yes	Recommend grouping parking lot count with the south lot.	539	Completed 2019	0
Stony Creek	Park Office	27	2	1	2	1	Yes	Appears to meet all requirements.	700	Completed 2019	0
Willow	Indian Ridge	49	2	1	2	1	Yes	Appears to meet requirements	593	Completed 2019	0
Willow	Flintwoods West	40	2	1	2	1	Yes	Appears to meet all requirements	593	Completed 2019	0
Willow	Flintwoods East	44	4	2	2	1	Yes	Appears to meet all requirements	593	Completed 2019	0
Willow	Elder Creek South	66	3	1	3	1	Yes	Appears to meet all requirements	593	Completed 2019	0
Willow	Elder Creek North	39	1	1	2	1	Yes	Appears to meet all requirements	593	Completed 2019	0
Willow	Chestnut North	99	4	1	4	1	Yes	Appears to meet all requirements	593	Completed 2019	0
Willow	Chestnut East	55	3	1	3	1	Yes	Appears to meet all requirements	593	Completed 2019	0
Willow	Chestnut South	46	2	1	2	1	Yes	Appears to meet requirements	593	Completed 2019	0
Willow	Big Bend West	79	3	1	4	1	Yes	Appears to meet all requirements	593	Completed 2019	0
Willow	Big Bend South	68	2	1	3	1	Yes	Appears to meet all requirements	593	Completed 2019	0
Willow	Washago Pond South	100	3	1	4	1	Yes	Appears to meet all requirements	593	Completed 2019	0
Wolcott Mill	Farm Center Service Yard	0	0	0	0	0	Yes	An accessible space may be required. Low priority.	Not available	Completed 2019	0
Dexter-Huron	Southwest Lot	38	0	0	2	1	No	Two accessible spaces needed for access to the picnic shelter.	To be determined	2021	1
Willow	Acorn Knoll South	56	0	0	3	1	No	Recommend locating two spaces close to the restrooms and one near the hike-bike trail connector.	To be determined	2021	1
Kensington	General Motors Road Lot	18	0	0	1	1	No	An accessible space may be required. Low priority.	To be determined	2023	2
Lake Erie	Boat Launch Overflow	29	0	0	2	1	No	Recommend adding two spaces for bird watchers that use the lot and for trail access.	To be determined	2023	2
Lower Huron	South Fishing Site	23	2	0	1	1	No	Striped van aisle needed. Convert one to van space with sign.	To be determined	2023	2
Wolcott Mill	Camp Rotary Equestrian Staging	10	0	0	1	1	No	An accessible parking space may be needed. Low priority. Turf lot.	To be determined	2023	2
Wolcott Mill	North Branch Trails	121	2	0	5	1	No	Pavement is in poor condition. Recommend relocation of spaces. Recommend moving closer to the trail entrance. Signs needed. Van sign needed. Striped van aisle needed. 3 Additional spaces needed.	To be determined	2023	2
Delhi	West Delhi	28	0	0	2	1	No	Recommend locating close to the kayak launch.	To be determined	2025	3
Kensington	Mitten Bay	40	0	0	2	1	No	Accessible spaces needed. Recommend locating close to the access path to the boat slips and hike-bike trail. Low priority.	To be determined	2025	3
Kensington	Island Road South Lot	40	0	0	2	1	No	Accessible spaces needed. Recommend locating 2 spaces on south side of lot, close to the water.	To be determined	2027	4
Kensington	Disc Golf	48	0	0	2	1	No	Accessible spaces may be needed. Low priority. Locate accessible spaces closest to the starter building.	To be determined	2027	4
Lower Huron	Ellwoods South	46	0	0	2	1	No	Recommend adding two spaces by gravel service path closest to restroom building. An accessible path should be considered connecting several picnic areas to Turtle Cove.	To be determined	2027	4
Lower Huron	Group Camp South	57	2	0	3	1	No	When the three lots are grouped together 6 spaces are required. Recommend locating all 6 spaces close to the restroom building and creating one or two accessible sites. Additional striping and signs needed. Van sign needed.	To be determined	2027	4
Lower Huron	Walnut Grove Lot 3	61	2	1	3	1	No	Site visit needed to verify compliance. Suggest counting all 3 lots together and dividing the required number between the North lot and Southeast lot. There is no reason to provide accessible spaces in the Southwest lot. 167 spaces require 6 spaces. Locate 3 in the Southeast lot.	To be determined	2027	4

Oakwoods	Equestrian Staging	16	0	0	1	1	No	Accessible space needed. Low priority.	To be determined	2027	4
Oakwoods	Cedar Knoll West	50	0	0	2	1	No	Accessible spaces needed. Redesign of the lot is being considered. Recommend grouping the parking totals from both lots and locating all accessible spaces within the West lot. Low priority until there are accessible amenities within the park.	To be determined	2027	4
Oakwoods	Cedar Knoll East	100	0	0	4	1	No	Accessible spaces needed. Recommend grouping the parking totals from both lots and locating all accessible spaces within the West lot. Low priority until there are accessible amenities within the park.	To be determined	2027	4
Stony Creek	West Branch Roadside Lot	26	0	0	1	1	No	One accessible needed. Recommend locating near restrooms. Signs and striping needed. New van aisle striping will reduce the lot total to 25 requiring one accessible space.	To be determined	2027	4
	West Branch South Lot	57	0	0	3	1	No	Three accessible spaces needed. Recommend grouping parking totals with the West Branch North West Lot and West Branch North East Lot.	To be determined	2027	4
Hudson Mills	Disc Golf	25	0	0	1	1	No	Accessible space may be needed. Low priority.	To be determined	2029	5
Hudson Mills	Group Camp Southwest Lot	20	0	0	1	1	No	May need an accessible parking space. Low priority.	To be determined	2029	5
Hudson Mills	Group Camp Southeast Lot	25	0	0	1	1	No	May need an accessible parking space. Low priority.	To be determined	2029	5
Hudson Mills	Group Camp Middle Lot	40	0	0	2	1	No	May need an accessible parking space. Low priority.	To be determined	2029	5
Hudson Mills	Group Camp East Lot	19	0	0	1	1	No	May need an accessible parking space. Low priority.	To be determined	2029	5
Hudson Mills	Group Camp North	20	0	0	1	1	No	May need an accessible parking space. Low priority.	To be determined	2029	5
Hudson Mills	Fishing Site	20	0	0	1	1	No	Recommend adding a space close to the trail. Leave space as an aggregate parking space. Low priority.	To be determined	2029	5
Kensington	Flagstaff	23	0	0	1	1	No	Accessible spaces may be needed. Recommend grouping parking totals with the Turtlehead Lot. These are parallel parking spaces on aggregate. No accessible facilities in the area.	To be determined	2029	5
Kensington	Playfield Roadside	34	0	0	2	1	No	Accessible parking spaces may be needed. Recommend grouping parking counts with the Possum Hollow.	To be determined	2029	5
Kensington	Route 3 Overlook Parking	24	0	0	1	1	No	An accessible space may be needed. Low priority.	To be determined	2029	5
Kensington	Overlook Parking (Office)	24	2	1	2	1	Yes	Appears to meet all requirements	To be determined	2029	5
Kensington	Mill Site (Dawson Road)	10	0	0	1	1	No	An accessible space may be required. Low priority.	To be determined	2029	5
Kensington	Equestrian Staging	0	0	0	0	0	Yes	An accessible space may be required. No formal parking lot. Low priority.	To be determined	2029	5
Kensington	Group Camp	0	0	0	0	0	Yes	Accessible spaces may be required. No formal parking lots. Low priority.	To be determined	2029	5
Lake Erie	Marina Overflow Lot	98	0	0	4	1	No	Gravel lot is not appropriate for HC parking spaces. When grouped with all the other lots at the Marina there are a sufficient number of accessible parking spaces.	To be determined	2029	5
Lower Huron	Par-3 Lot	79	2	1	4	1	No	Parking area is currently closed. Two additional spaces needed. Striped aisles needed. Van aisle needed. Van sign needed.	To be determined	2029	5
Lower Huron	Pool Service Yard	4	0	0	1	1	No	May need an accessible parking space. Low priority.	To be determined	2029	5
Lower Huron	Walnut Grove Lot 2	64	0	0	3	1	No	Striping is not needed in this overflow camping lot.	To be determined	2029	5
Stony Creek	Oakgrove Roadside Lot	43	0	0	2	1	No	Recommend grouping parking counts with Oakgrove West. There are no amenities near this lot.	To be determined	2029	5
Stony Creek	Trolley Trails	24	0	0	1	1	No	An accessible van space is needed. Low priority. Recommend leaving parking space unpaired.	To be determined	2029	5

Stony Creek	Inwood	10	0	0	1	1	No	Accessible parking space needed. Low priority. Recommend leaving parking space unpaved.	To be determined	2029	5
Willow	Acorn Knoll North (disc golf)	50	0	0	2	1	No	Accessible parking spaces may be needed. Low priority.	To be determined	2029	5
Willow	Service Yard	0	0	0	0	0	Yes	Accessible parking spaces may be needed. Low priority.	To be determined	2029	5
Willow	Big Bend 2	25	0	0	1	1	No	Recommend grouping parking lot numbers with the south lot. There are no accessible facilities in the area.	To be determined	2029	5
Wolcott Mill	Shorian Lodge	5	1	0	1	1	No	New van aisle striping needed. Sign needed. Van sign needed.	To be determined	2029	5
Wolcott Mill	Model Airplane Field	23	0	0	1	1	No	An accessible space may be required. Low priority.	To be determined	2029	5
Oakwoods	Equestrian Staging	16	0	0	1	1	No	Accessible space needed. Low priority.	To be determined	2027	4
Lake St. Clair	Boat Launch	141	7	3	5	1	Yes	Appears to meet requirements	Not available	Completed	0
Lower Huron	Pool Service Yard	4	0	0	1	1	No	May need an accessible parking space. Low priority.	To be determined	2029	5
Kensington	Park Office	24	2	1	1	1	No	Signs appear to be installed too short. Striped van aisle needed. Van sign needed. Fix crumbled concrete at door threshold. Secure entrance carpet.	To be determined	2021	1
Kensington	Equestrian Staging	0	0	0	0	0	Yes	An accessible space may be required. No formal parking lot. Low priority.	To be determined	2029	5
Indian Springs	Prison Site	0	0	0	0	0	Yes	No designated parking spaces. Accessible spaces not required.	Not available	Completed	0
Lake St. Clair	Park Office	24	1	1	1	1	Yes	Appears to meet all requirements	Not available	Completed	0
Indian Springs	Park Office	76	4	4	4	1	Yes	Appears to meet all requirements.	Not available	Completed	0
Stony Creek	Park Office	27	2	1	2	1	Yes	Appears to meet all requirements.	Not available	Completed	0
Wolcott Mill	Camp Rotary Campfire	17	1	1	1	1	Yes	An accessible route is needed to the campfire, recommend an additional space near campfire route.	To be determined	2029	5
Wolcott Mill	Camp Rotary Equestrian Staging	10	0	0	1	1	No	An accessible parking space may be needed. Low priority. Turf lot.	To be determined	2029	5
Kensington	Canoe Camp/Livery	0	0	0	1	1	No	Suggest one ADA parking for van	To be determined	2027	4

PRIORITY 4. SECONDARY RECREATIONAL VISITOR APPROACH AND ENTRANCE AREAS

Park	Location	Description	Justification/Solution	Cost	Timeline	Priority Ranking
Lake St. Clair	Porta John Locations	Recommend locating porta johns on pavement or an aggregate surface that meets accessibility requirements.	Easily accomplished.	To be determined	2021	1
Kensington	General Motors Lot	Improved access desired from the lot to the hike-bike trail.	A more direct way to access the trail is desired.	To be determined	2027	1
Wolcott Mill	North Branch Trails	Improve access desired to the trails. Parking bumpers block access at this time. Relocate porta johns and accessible parking spaces closer to the access point. Verify access points are wide enough and cross slopes at access point meet standards.	New projects should meet accessibility standards.	To be determined	2021	1
Lower Huron	Group Camp	Accessible walks desired connecting an accessible campsite, parking lot, restrooms, fire pit, and shelter.	Consider relocating the shelter to a location closer to the restrooms and parking to minimize lengthy walks.	To be determined	2029	2
Lower Huron	Group Camp Fountain	Accessible walk desired to the accessible drinking fountain.	Consider removing or relocating to a location along a path.	To be determined	2029	2
Kensington	Group Camp Amphitheater	Accessible walks desired connecting a parking area, camp site, and the amphitheater.	Low priority.	To be determined	2029	2
Kensington	Windfall	Accessible walks desired connecting the parking lot, shelter, and restrooms.	Area is closed most of the time. Only use is when rented. Consider relocation of restrooms closer to the hike-bike trail for increased use. May want to remove facilities if the area is not opened to the public.	To be determined	2029	2
Kensington	Playfield Vault Latrines	Accessible walk desired to the women's restroom.	Men's has an access walk. Women's doesn't.	To be determined	2029	2
Kensington	Group Camp Sites	Accessible walks desired connecting the parking lot, restrooms, fire pit area, and accessible camp site.	Consider having one designated accessible camp site.	To be determined	2025	2
Lower Huron	Walnut Grove Playground	Accessible walk desired to the accessible playground. Recommend aligning the walk with the walk to the restrooms.	Difficult playground for the public to access unless you are a camper.	To be determined	2029	3
Lower Huron	Woods Creek Playground	Improved access desired to the accessible playground and accessible drinking fountain.	There is access. The playground is scheduled for removal and replacement. There may be a new location proposed for the playground.	To be determined	2029	3
Kensington	Equestrian Staging Area	Accessible walk desired in front of the trailhead structure.	Low priority. Provide a surface that is firm and stable with a running slope no steeper than 5% and a cross slope not steeper than 2%, a minimum clear width of 36" .	To be determined	2029	3
Oakwoods	Equestrian Staging Area	Accessible walk desired to restrooms. Recommend installing pedestrian crossing signs at the road for access to the porta john or adding another porta john at the equestrian staging area. Recommend replacing the existing porta john with an accessible unit.	Access to restrooms is on the opposite side of the park road. The existing porta john is not an accessible unit and not located in an accessible location.	To be determined	2027	3
Kensington	West Boat Launch Playground	Wider accessible walk desired.	Access walks should be 6' minimum width for universal access.	To be determined	2025	3

Wolcott Mill	Equestrian Staging Area	Accessible walk desired to and in front of the trailhead structure.	All trailheads should be located in accessible locations. Provide a surface that is firm and stable with a running slope no steeper than 5% and a cross slope not steeper than 2%, a minimum clear width of 36" .	To be determined	2025	3
Lower Huron	Basketball Court Access	Accessible walk desired to the basketball courts. Access to the tennis court and basketball courts are in different locations. Recommend having access to both courts from the main walk.	Accessible basketball courts are located in other parts of the park. Provide a surface that is firm and stable with a running slope no steeper than 5% and a cross slope not steeper than 2%, a minimum clear width of 36" .	To be determined	2029	4
Lake Erie	Boat Launch Overflow Lot	Accessible walk desired connecting the overflow lot, bird counting area, and minor trailhead.	Popular location for trail access. The flatness of the nature trail makes it almost compliant with accessibility requirements.	41,580	2023	2
Lower Huron	Tennis Court Access	Improved access to the tennis court is desired. Gate access is on the side opposite of the parking lot. A gate is needed to provide access between the basketball court and tennis court on the parking lot side of the court.	This is the only tennis court in the park. Court is deteriorating and has little use. Provide a surface that is firm and stable with a running slope no steeper than 5% and a cross slope not steeper than 2%, a minimum clear width of 36" .	To be determined	2029	4
Lake Erie	Basketball Court Access	Accessible walk desired connecting the Great Wave Activity Area to the basketball courts.	A paved path connects the lot to the basketball courts but does not provide access to accessible parking spaces or the Great Wave Activity Area.	5,740	2023	4
Hudson Mills	Disc Golf Course	Accessible route needed	Does not meet standards. Provide a surface that is firm and stable with a running slope no steeper than 5% and a cross slope not steeper than 2%, a minimum clear width of 36" .	To be determined	2029	5
Kensington	Administrative Office	Improved ramp access desired.	1:10 slope flares required on ramps.	To be determined	2029	5
Kensington	Disc Golf Course	Accessible walks desired connecting the parking lot, starter building, porta johns, shelter, and kiosk structure.	No access paths to these facilities at this time. Access is not an issue if they are able to play disc golf.	To be determined	2029	5

PRIORITY 5. NON-ESSENTIAL PARK USER RECREATIONAL SUPPORT, FACILITY SERVICES

Park	Location	Description	Justification/Solution	Cost	Timeline	Park Ranking2
Lake St. Clair	Porta John Locations	Recommend locating porta johns on pavement or an aggregate surface that meets accessibility requirements.	Easily accomplished.	To be determined	2029	2
Kensington	Park Office	Service counter, entrance mats	Does not meet standards. Provide a section of counter that is 28" to 36" and is at least 24" long in alterations. Provide a mat with a heavier backing or tape the mat to the floor.	To be determined	2029	5
Lake Erie	Office	Restrooms need accessibility improvements. Service counter exceeds counter height limit. Signs do not meet standards.	Remove obstructions to meet front approach maneuvering clearance, adjust door closers, relocate garbage cans obstructing clear path, adjust lavatory mirror and hooks, insulate pipes, move toilets and adjust stall widths to meet 60 inches. Grab bar relocations and flush control on open side. Front approach to stall does not meet maneuvering clearance.	To be determined	2029	5
Indian Springs	Office	Readjust door closer, secure carpet	Does not meet standards. Adjust the closer and provide a mat with a heavier backing or tape the mat to the floor.	To be determined	2029	5
Lake St. Clair	Park Office Parking Lot	Accessible walk desired from the employee parking lot to the park office. Ramp required.	Accessible spaces were recently removed from the lot when it was restriped. Ramped access desired at all employee entrances.	To be determined	2029	5
Lake St. Clair	Park Office	Ramp needed.	Provided a new curb ramp with a running slope no steeper than 8.3% and a cross slope no steeper than 2% and a smooth transition with 6' flares.	To be determined	2029	5
Stony Creek	Park Office	Improved ramp access desired. Reconstruct the ramp to meet current standards. 60" turning space required.	Park offices should be accessible. Provide a new ramp with a running slope no steeper than 8.3%, a cross slope no steeper than 2% and handrails on both sides that are mounted to 34" to 38" to the top of the gripping surface.	To be determined	2029	5
Kensington	Office	Service Counter	Does not meet standards. Provide a section of counter that is 28" to 36" and is at least 24" long in alterations.	To be determined	2029	5
Lower Huron	Office	Door hardware, closer adjustments, service counters	Does not meet standards. Door hardware and closer needs updating. Provide a section of counter that is 28" to 36" and is at least 24" long in alterations.	To be determined	2029	5
Lake St. Clair	Park Office Parking Lot	Accessible walk desired from the employee parking lot to the park office. Ramp required.	Accessible spaces were recently removed from the lot when it was restriped. Ramped access desired at all employee entrances.	To be determined	2029	5
Wolcott Mill	Model Airplane Field	Accessible walks desired connecting the parking lot, building, restrooms, a repair station, and a control station.	Facility maintained by another organization and not open to the general public.	To be determined	2029	5

PRIORITY 6. FACILITIES NEEDING FURTHER STUDY FOR FUTURE USE, RENOVATION, REPLACEMENT, OR REMOVAL

Park	Location	Description	Justification/Solution	Cost	Timeline	Park Ranking2
Wolcott Mill	Farm Center/Dairy Farm	Improved access desired to the small animal bar. Maintenance needed to remove tripping hazard.	A trip hazard exists preventing wheel chair access. Existing ramps need hand rails to meet standards. Replace inaccessible knobs. Note not part of this checklist, chicken coup is not accessible, horse barn and green house not accessible route or entrance. Existing aggregate paths may not meet accessibility standards. Master Plan for Farm Center under conceptual design, wait for preliminary design to implement ADA improvements.	To be determined	2021	1
Hudson Mills	Rapids View	Accessible walks desired to the vault latrines, hike-bike trail, and kayak launch.	Recommend waiting until there is a master plan for this area. Expanded parking, restrooms, and a drop off area for kayak unloading have been discussed.	To be determined	2021	1
Lake St. Clair	Boardwalk Shelter	Accessible walks desired connecting the boardwalk, shuttle stop, and future restroom building. Recommend waiting until there are plans made for the new restroom building.	No access at this time. Accessible restrooms needed.	To be determined	2023	2
Lake St. Clair	Creek View Shelter	Accessible walks desired connecting the boardwalk, shuttle stop, and future restroom building. Recommend waiting until there are plans made for the new restroom building.	No access at this time. Accessible restrooms needed.	To be determined	2023	2
Willow	Big Bend Restrooms	Accessible walk desired connecting the picnic shelter and restrooms. 470' of walk needed.	There are topography issues. Consider relocating the shelter in the future closer to existing restrooms.	To be determined	2023	2
Delhi	West Delhi	Access walks desired connecting the parking lot, restroom, and kayak launch.	The facility is very busy. The parking lot is in overflow regularly.	To be determined	2023	2
Wolcott Mill	Farm Center/Office	Main access routes	Running slope -7.3% treated as ramp for the concrete entrance to the Farm Center/Office.	To be determined	2023	2
Wolcott Mill	Farm Center	Improved surfacing desired to the upper shelter. Recommend paving a short segment of aggregate road leading o the upper picnic shelter. Ramp may be needed along route to park office.	Very short 20' segment, used heavily. Consider adding to the playground renovation project.	To be determined	2023	2
Stony Creek	Boat Rental	Restrooms need accessibility improvements. Entrance front approach standard and vertical threshold not met, door swing clearance and single user toilet room needs altering. Mirror exceeds height limit, insulation of pipes, towel dispenser exceed height max., various standards not met in bathroom stall.	Staff is currently presenting to Board various conceptual designs that include restroom improvements.	To be determined	2027	4
Wolcott Mill	Farm Center	Accessible walk desired to the spectating viewing area at the animal arena.	Access needed for this event area.	To be determined	2023	2
Wolcott Mill	Farm Center	Accessible walk desired connecting the Lower Shelter to the Farm Center / Restrooms.	Topography issues. Shelter is not rented that much. 410' of path needed.	To be determined	2023	2
Wolcott Mill	Farm Center	Accessible walk desired to the fishing dock.	Not used much. Consider grouping with the access walk project to the Lower Shelter. 185' of path needed.	To be determined	2023	2
Delhi	Skips Canoe Livery	General improvements needed to the area including accessible parking and walks to various buildings.	On the edge of the Natural Rivers Area. May require a permit for any type of work on, above, or below the ground.	To be determined	2027	4
Lake Erie	Marina Building	Goods and services accessibility improvements.	Interior doors do not meet threshold vertical height limit. Carpet is not secured along edges. Move garbage can from obstructing light switch. Service counter is higher than 36 inches.	To be determined	2029	5

PRIORITY 7. PHYSICAL STRUCTURAL BARRIERS IN FACILITIES THAT IMPEDE PARK EMPLOYEE BUT NOT GENERAL PUBLIC

Park	Location	Total Spaces	Total # of HC Spaces	# that are Van Accessible	Required HC Spaces	Required Van Spaces	Space Meet All Requirements	Notes/Solution	Cost	Timeline	Priority Ranking
Lake St. Clair	Nature Center Employee Lot	26	3	3	2	1	Yes	Appears to meet all requirements.	1,185	Completed 2019	0
Indian Springs	Prison Site	0	0	0	0	0	NA	No designated parking spaces. Accessible spaces not required.	Not available	Completed	0
Indian Springs	Golf Service Yard	0	0	0	0	0	NA	Accessible spaces may be needed. Low priority.	Not available	Completed	0
	West Branch South Lot	57	0	0	3	1	No	Three accessible spaces needed. Recommend grouping parking totals with the West Branch North West Lot and West Branch North East Lot.	To be determined	2027	4
Hudson Mills	Maintenance Yard 1	22	0	0	1	1	No	Accessible space may be needed. Low priority. An accessible ramp will be needed if added.	To be determined	2027	4
Lake Erie	Maintenance Yard	17	0	0	1	1	No	An accessible space may be required. Low priority.	To be determined	2027	4
Lake Erie	Golf Course Service Yard	0	0	0	1	1	No	An accessible space may be required.	To be determined	2027	4
Lower Huron	Maintenance Yard	8	0	0	1	1	No	May need an accessible parking space. Low priority.	To be determined	2027	4
Willow	Service Yard	0	0	0	0	0	NA	Accessible parking spaces may be needed. Low priority.	To be determined	2029	5
Hudson Mills	Maintenance Yard 2	0	0	0	0	0	NA	Accessible space may be needed. Low priority.	To be determined	2029	5
Lake St. Clair	Maintenance Yard	7	0	0	1	1	No	ADA spaces may be needed within facility. Plenty of areas to park if needed.	To be determined	2029	5
Hudson Mills	Golf Course Service Yard	0	0	0	0	0	NA	Accessible space may be needed. Low priority.	To be determined	2029	5
Huron Meadows	Golf Service Yard	0	0	0	0	0	NA	Accessible space may be needed. Low priority.	To be determined	2029	5
Huron Meadows	Engineering Office	5	0	0	1	1	No	Accessible space may be needed. Low priority.	To be determined	2029	5
Stony Creek	Golf Course Service Yard	0	0	0	0	0	Yes	An accessible space may be needed. Low priority. Currently parking on the sanitary tile field. A small staff parking lot is needed.	Not available	Completed 2019	0
Stony Creek	Service Yard	33	0	0	2	1	No	Accessible spaces may be needed. Low priority.	To be determined	2029	5
Kensington	Golf Service Yard	5	0	0	0	0	No	Accessible space may be needed. Low priority.	To be determined	2029	5
Wolcott Mill	History Center Employee Lot	10	1	1	1	1	Yes	Appears to meet all requirements. Consider signing a second accessible space if this parking area is open to the public and the area is used for event parking.	To be determined	2029	5
Lower Huron	Park Office and Employee Lots	38	1	0	2	1	No	The three lots combined require 2 spaces. One additional space needed. Striped van aisle needed. Van sign needed. Pavement is in terrible condition. New Park Office location proposed.	To be determined	2029	5
Lower Huron	Par-3 Maintenance Area	0	0	0	0	0	NA	May need an accessible parking space. Low priority.	To be determined	2029	5
Kensington	Park Office and Employee Lots										
Kensington	Maintenance Yard	81	0	0	4	1	No	Accessible spaces may be needed in multiple locations throughout the facility. Low priority.	To be determined	2029	5



APPENDIX 3: PICNIC FACILITIES MAPS

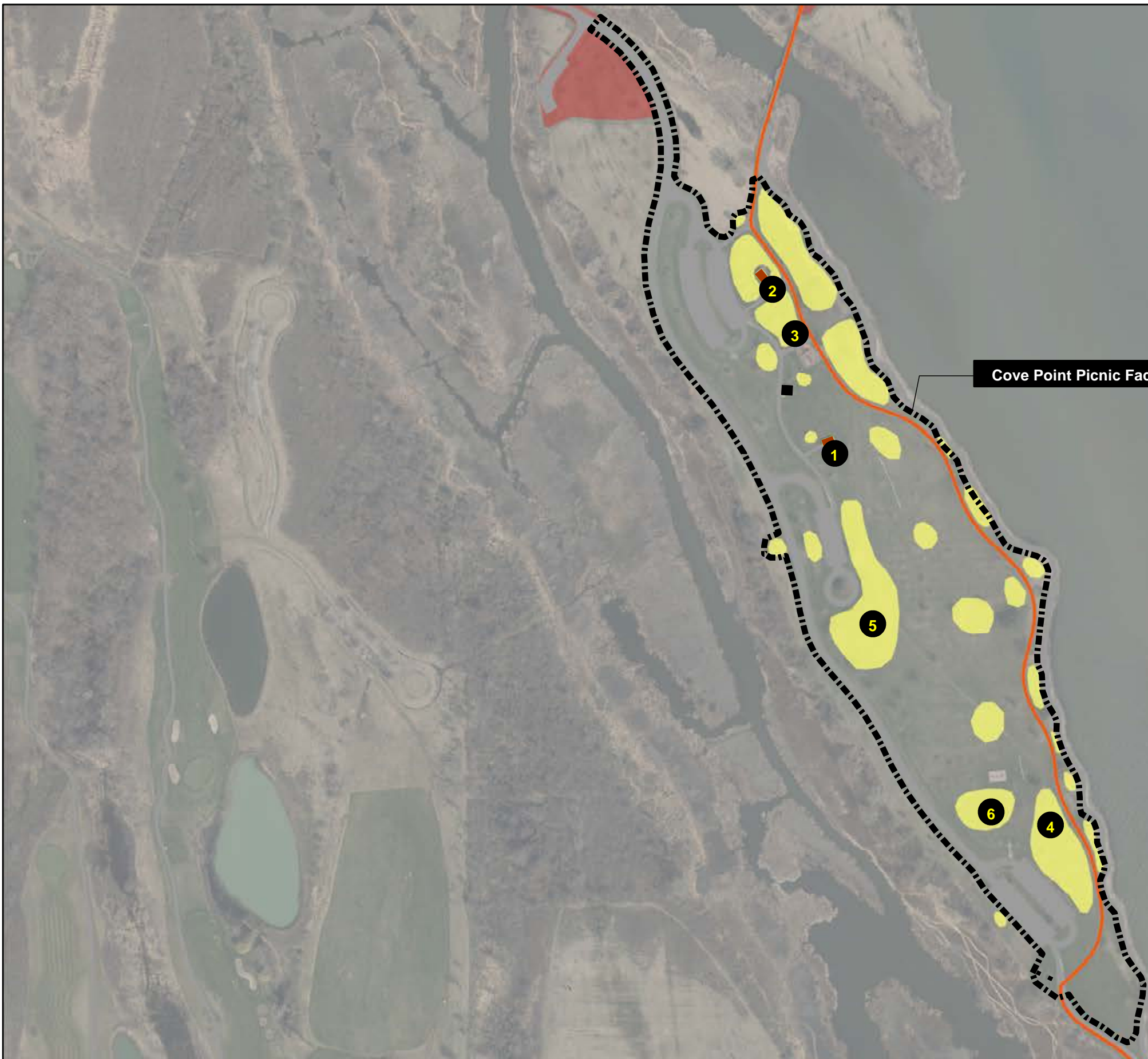



Cove Point Picnic Facility Boundary

Picnic Unit Ranking

-  Cove Point Picnic Facility
-  Buildings
-  Picnic Shelters
-  Picnic Units with Facility
-  Hike-Bike Trail
-  Constructed Surfaces
-  Other Picnic Facilities

- 1** Muskrat (E) is the most rented shelter in this area. Combine tables counted surrounding the shelter when calculating necessary accessible table ratio under shelter. The existing grill needs to be accessible.
- 2** Wood Duck (D) is the second most rented shelter in area. Combine some tables counted surrounding shelter when calculating necessary accessible table ratio under shelter. The existing grill is located along a walkway. Grill needs to be accessible.
- 3** Two accessible tables needed. Two accessible grills needed. Locate accessible tables and grills along the existing walkways.
- 4** Meet ratio requirements for accessible tables and grills. Add necessary accessible routes or locate along existing hike-bike trail.
- 5** Divide this large area into two picnic units. Make one of them an accessible picnic unit. Meet ratio requirements for accessible tables and grills. Add necessary accessible routes as needed.
- 6** Meet ratio requirements for accessible tables and grills. Add necessary accessible routes. Two free picnic areas recommended at each lot.

Created by JPB, 9/12/2019



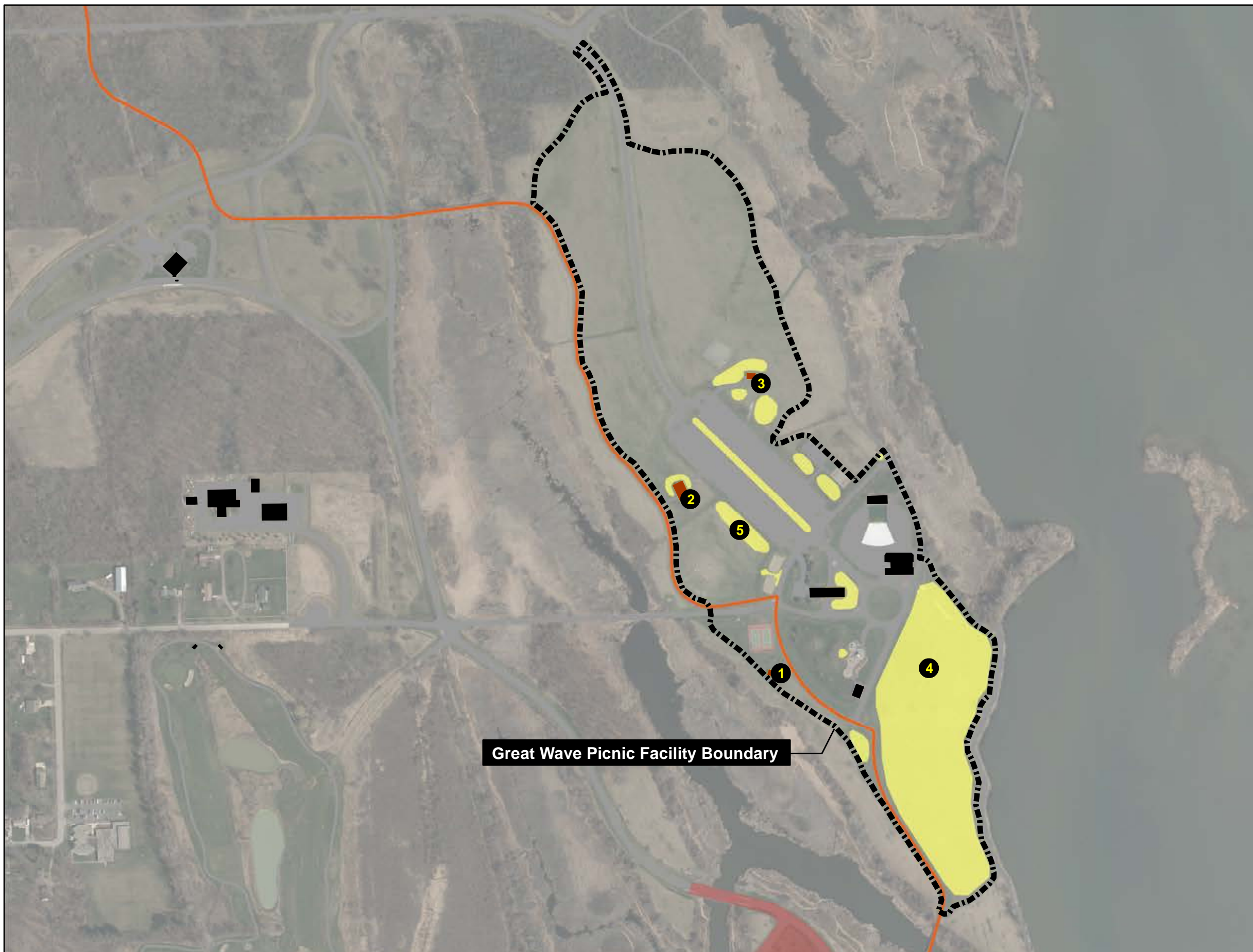

Great Wave Picnic Facility Boundary

Picnic Unit Ranking

-  Great Wave Picnic Area
-  Buildings
-  Picnic Shelters
-  Picnic Facilities selection
-  Hike-Bike Trail
-  Other Picnic Facilities
-  Constructed Surfaces

- 1** Cattail (C) is the most rented shelter in this area. Combine some tables counted surrounding the shelter when calculating necessary accessible table ratio under shelter. The existing grill needs to be accessible.
- 2** Blue Heron (B) is the second most rented shelter in this area. Combine all tables counted surrounding shelter when calculating necessary accessible table ratio under shelter. Two accessible grills needed.
- 3** American Lotus (A) is the third most rented shelter in area. Combine some tables counted surrounding shelter when calculating necessary accessible tables. Existing grill needs to be accessible. Accessible walk needed to restrooms / activity area.
- 4** Divide this large unit into two and make one of them accessible. Meet accessible table and grill ratio requirements. Locate the accessible tables and grill near the existing walk.
- 5** Meet ratio requirements for accessible tables and grills. Add accessible walks as needed and connect to Great Wave walkways for restroom, pool, playground, and food bar access.

Created by JPB, 9/12/2019



Picnic Unit Ranking

Marina Point Picnic Facility

Buildings

Picnic Shelters

Picnic Units with Facility

Hike-Bike Trail

Other Picnic Facilities

Constructed Surfaces

1 Two accessible tables needed. One of the tables is an accessible table but lacks an accessible route to the table. Modify another table and construct access paths as needed.

2 Two of the tables are accessible. No work needed.

Created by JPB, 9/12/2019

Marina Point Picnic Facility Boundary



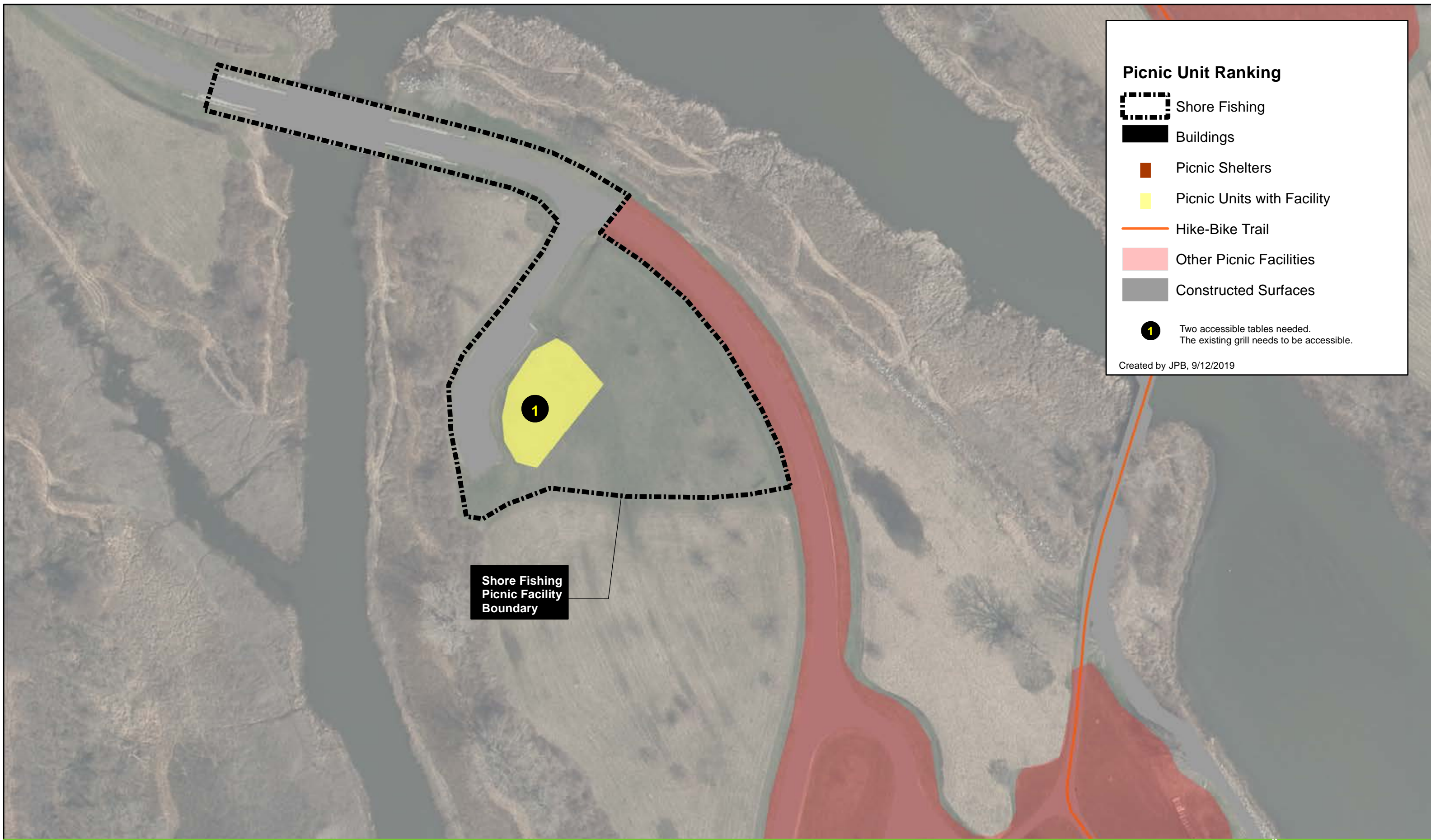

Picnic Unit Ranking

-  Shore Fishing
-  Buildings
-  Picnic Shelters
-  Picnic Units with Facility
-  Hike-Bike Trail
-  Other Picnic Facilities
-  Constructed Surfaces
-  Two accessible tables needed. The existing grill needs to be accessible.

Created by JPB, 9/12/2019

Shore Fishing
Picnic Facility
Boundary



Picnic Unit Ranking

 Other Picnic Facilities selection

 Buildings

 Picnic Shelters

 Picnic Units with Facility

 Hike-Bike Trail

 Constructed Surfaces

 Other Picnic Facilities

1 Two accessible tables needed. Locate accessible tables along a new accessible route from the parking lot the vault latrines. The existing grill needs to be accessible.

2 Two accessible tables needed. Locate accessible tables along a new accessible route from the parking lot the vault latrines. Add an accessible grill so that there are two within the Cedar Knoll picnic facility.

Created by JPB, 9/19/2019

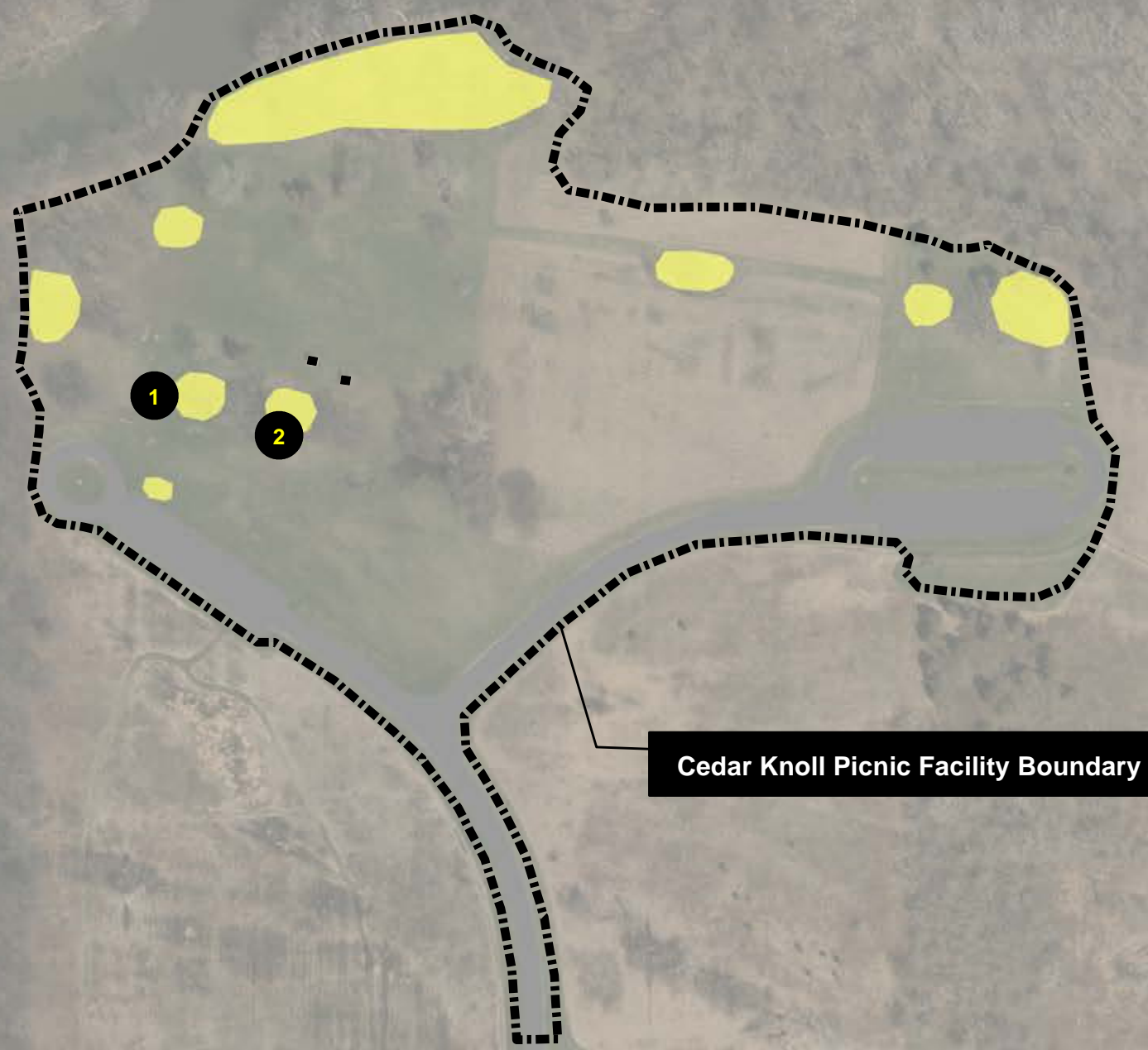

Cedar Knoll Picnic Facility Boundary



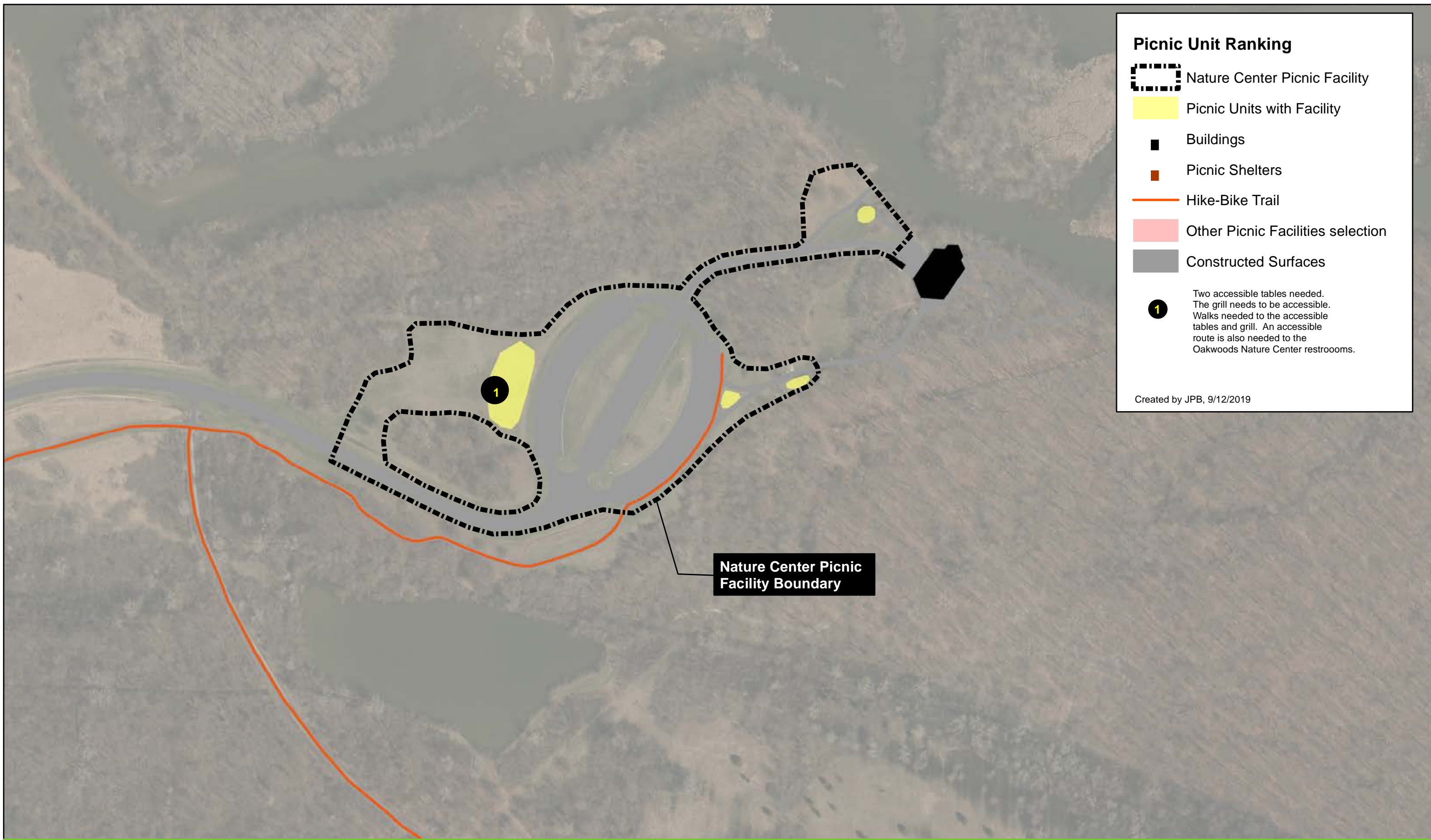

Picnic Unit Ranking

 Nature Center Picnic Facility

 Picnic Units with Facility

 Buildings

 Picnic Shelters

 Hike-Bike Trail

 Other Picnic Facilities selection

 Constructed Surfaces

 Two accessible tables needed. The grill needs to be accessible. Walks needed to the accessible tables and grill. An accessible route is also needed to the Oakwoods Nature Center restrooms.

Created by JPB, 9/12/2019

Nature Center Picnic Facility Boundary



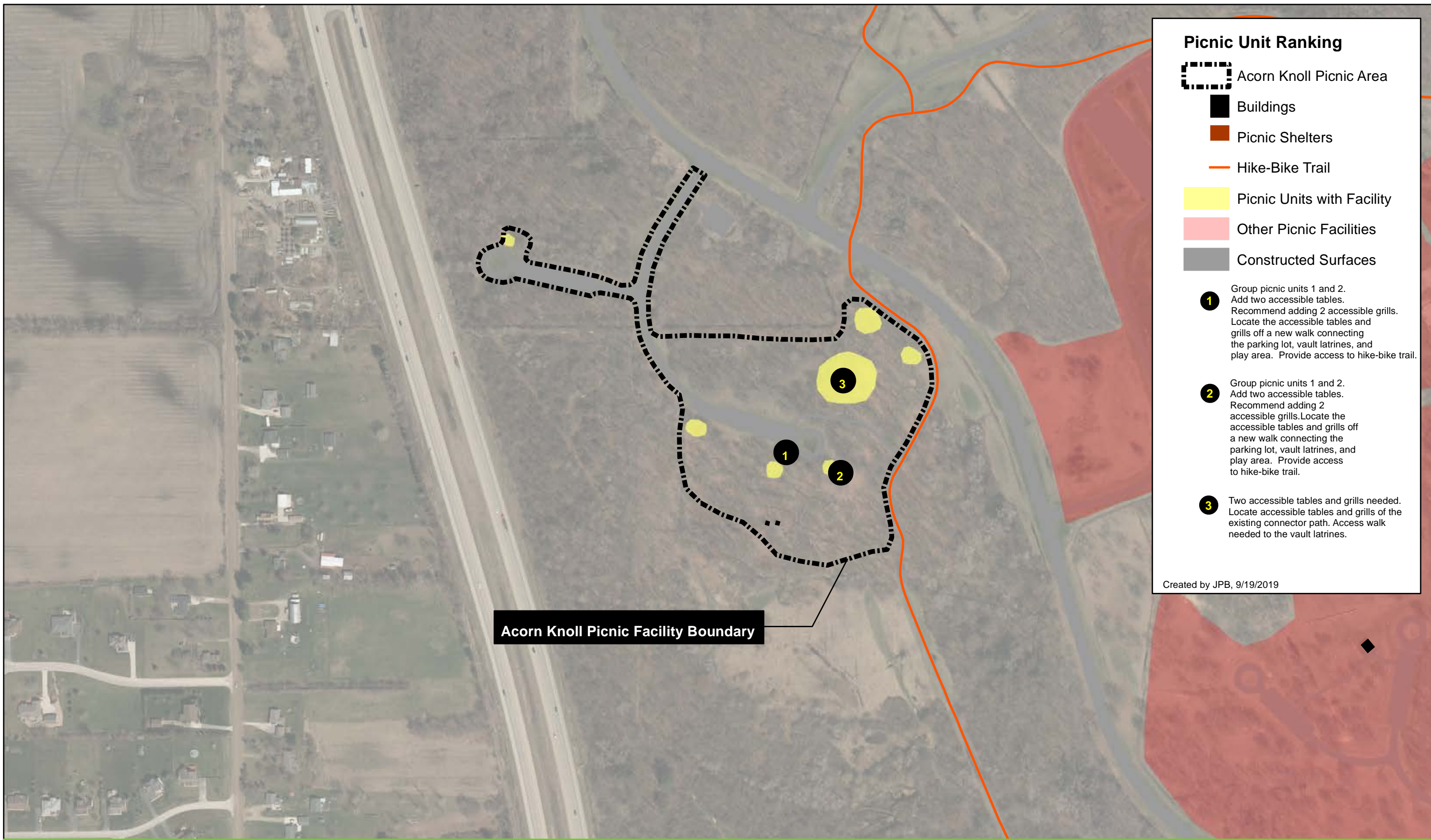

Picnic Unit Ranking

-  Acorn Knoll Picnic Area
-  Buildings
-  Picnic Shelters
-  Hike-Bike Trail
-  Picnic Units with Facility
-  Other Picnic Facilities
-  Constructed Surfaces

1 Group picnic units 1 and 2. Add two accessible tables. Recommend adding 2 accessible grills. Locate the accessible tables and grills off a new walk connecting the parking lot, vault latrines, and play area. Provide access to hike-bike trail.

2 Group picnic units 1 and 2. Add two accessible tables. Recommend adding 2 accessible grills. Locate the accessible tables and grills off a new walk connecting the parking lot, vault latrines, and play area. Provide access to hike-bike trail.

3 Two accessible tables and grills needed. Locate accessible tables and grills of the existing connector path. Access walk needed to the vault latrines.

Created by JPB, 9/19/2019

Acorn Knoll Picnic Facility Boundary

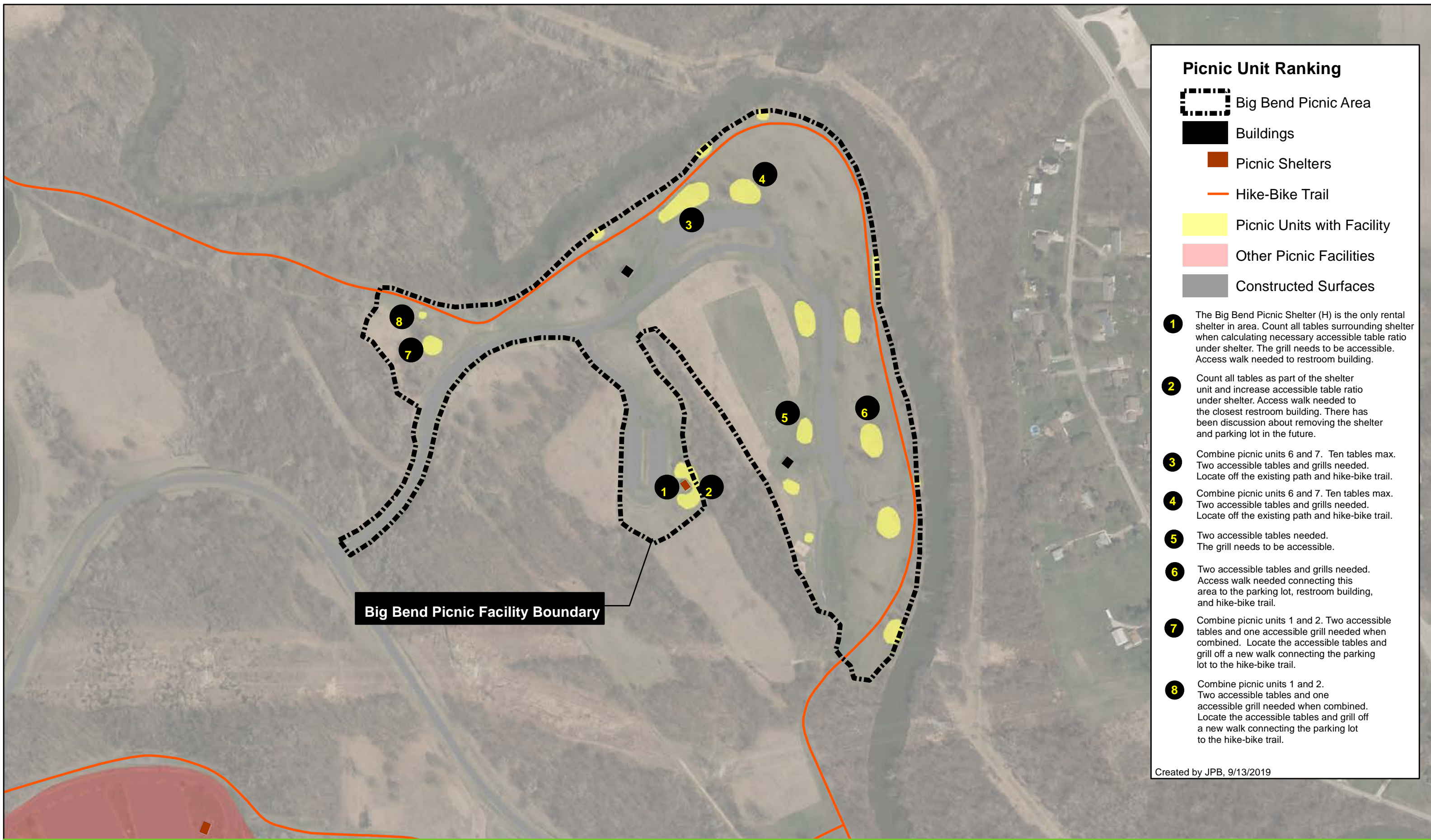

Picnic Unit Ranking

-  Big Bend Picnic Area
-  Buildings
-  Picnic Shelters
-  Hike-Bike Trail
-  Picnic Units with Facility
-  Other Picnic Facilities
-  Constructed Surfaces

- 1** The Big Bend Picnic Shelter (H) is the only rental shelter in area. Count all tables surrounding shelter when calculating necessary accessible table ratio under shelter. The grill needs to be accessible. Access walk needed to restroom building.
- 2** Count all tables as part of the shelter unit and increase accessible table ratio under shelter. Access walk needed to the closest restroom building. There has been discussion about removing the shelter and parking lot in the future.
- 3** Combine picnic units 6 and 7. Ten tables max. Two accessible tables and grills needed. Locate off the existing path and hike-bike trail.
- 4** Combine picnic units 6 and 7. Ten tables max. Two accessible tables and grills needed. Locate off the existing path and hike-bike trail.
- 5** Two accessible tables needed. The grill needs to be accessible.
- 6** Two accessible tables and grills needed. Access walk needed connecting this area to the parking lot, restroom building, and hike-bike trail.
- 7** Combine picnic units 1 and 2. Two accessible tables and one accessible grill needed when combined. Locate the accessible tables and grill off a new walk connecting the parking lot to the hike-bike trail.
- 8** Combine picnic units 1 and 2. Two accessible tables and one accessible grill needed when combined. Locate the accessible tables and grill off a new walk connecting the parking lot to the hike-bike trail.

Created by JPB, 9/13/2019

Big Bend Picnic Facility Boundary

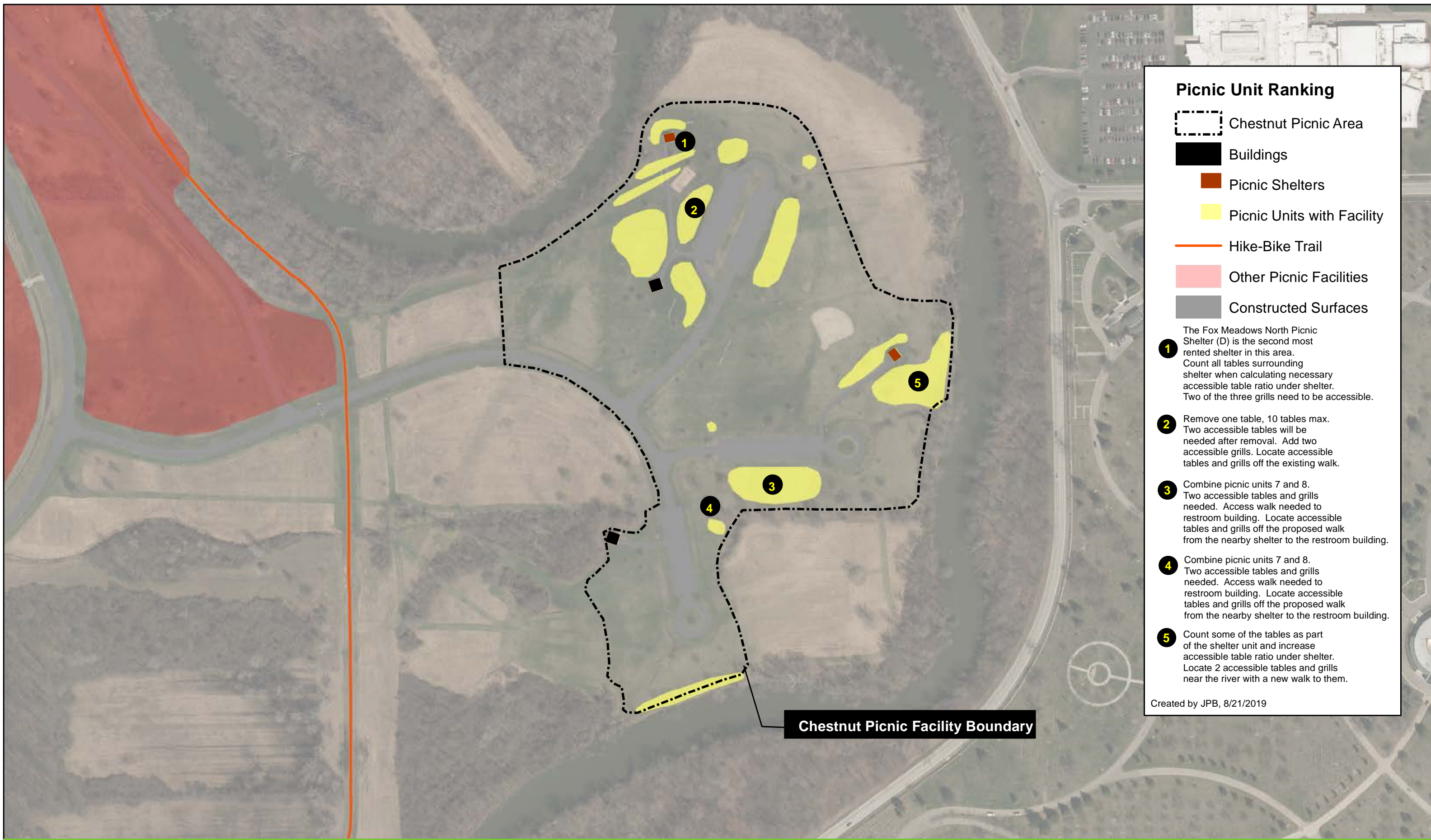

Picnic Unit Ranking

- Chestnut Picnic Area
- Buildings
- Picnic Shelters
- Picnic Units with Facility
- Hike-Bike Trail
- Other Picnic Facilities
- Constructed Surfaces

- The Fox Meadows North Picnic Shelter (D) is the second most rented shelter in this area.
- 1** Count all tables surrounding shelter when calculating necessary accessible table ratio under shelter. Two of the three grills need to be accessible.
 - 2** Remove one table, 10 tables max. Two accessible tables will be needed after removal. Add two accessible grills. Locate accessible tables and grills off the existing walk.
 - 3** Combine picnic units 7 and 8. Two accessible tables and grills needed. Access walk needed to restroom building. Locate accessible tables and grills off the proposed walk from the nearby shelter to the restroom building.
 - 4** Combine picnic units 7 and 8. Two accessible tables and grills needed. Access walk needed to restroom building. Locate accessible tables and grills off the proposed walk from the nearby shelter to the restroom building.
 - 5** Count some of the tables as part of the shelter unit and increase accessible table ratio under shelter. Locate 2 accessible tables and grills near the river with a new walk to them.

Created by JPB, 8/21/2019

Chestnut Picnic Facility Boundary

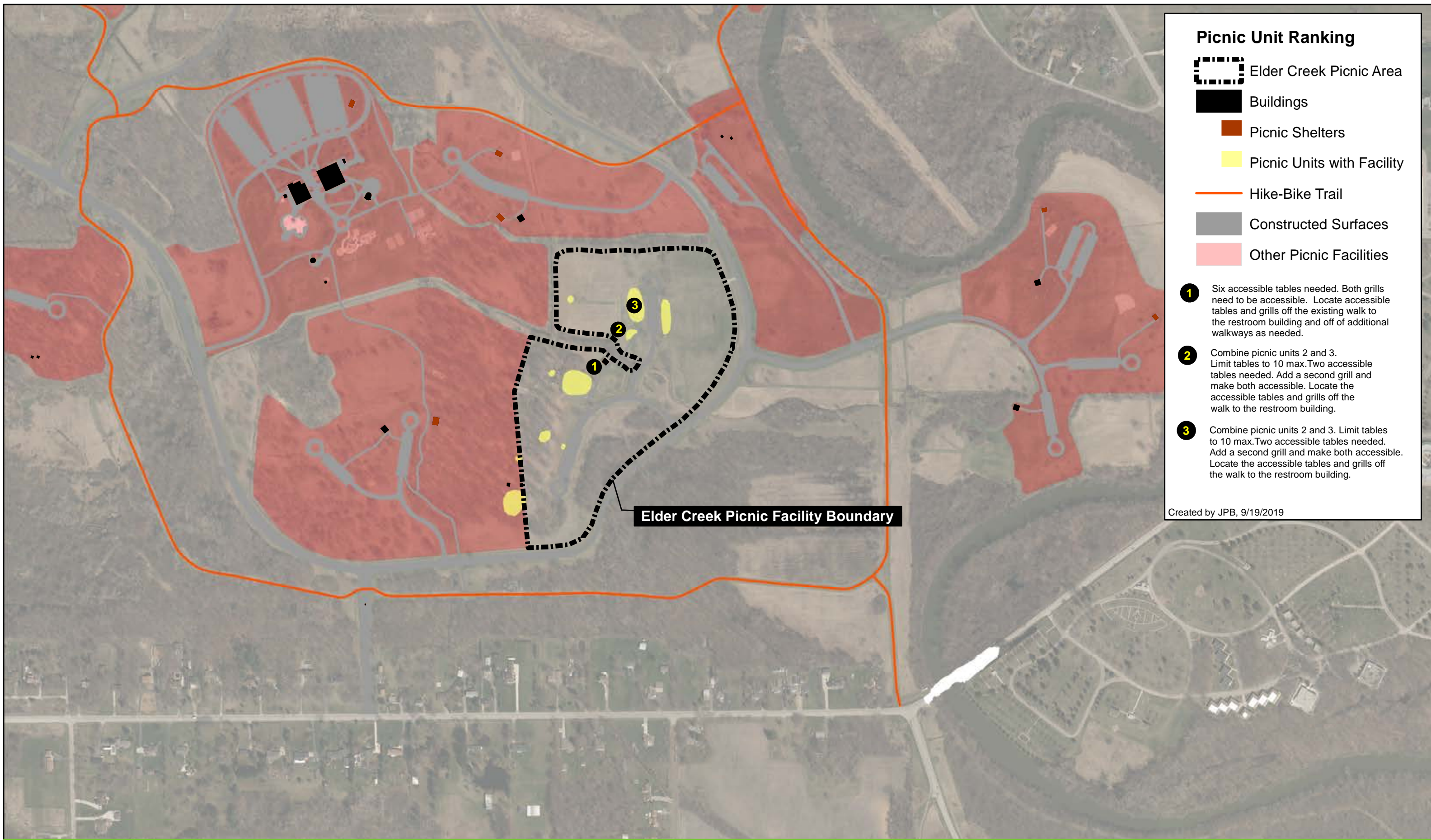

Picnic Unit Ranking

-  Elder Creek Picnic Area
-  Buildings
-  Picnic Shelters
-  Picnic Units with Facility
-  Hike-Bike Trail
-  Constructed Surfaces
-  Other Picnic Facilities

- 1** Six accessible tables needed. Both grills need to be accessible. Locate accessible tables and grills off the existing walk to the restroom building and off of additional walkways as needed.
- 2** Combine picnic units 2 and 3. Limit tables to 10 max. Two accessible tables needed. Add a second grill and make both accessible. Locate the accessible tables and grills off the walk to the restroom building.
- 3** Combine picnic units 2 and 3. Limit tables to 10 max. Two accessible tables needed. Add a second grill and make both accessible. Locate the accessible tables and grills off the walk to the restroom building.

Created by JPB, 9/19/2019

Elder Creek Picnic Facility Boundary

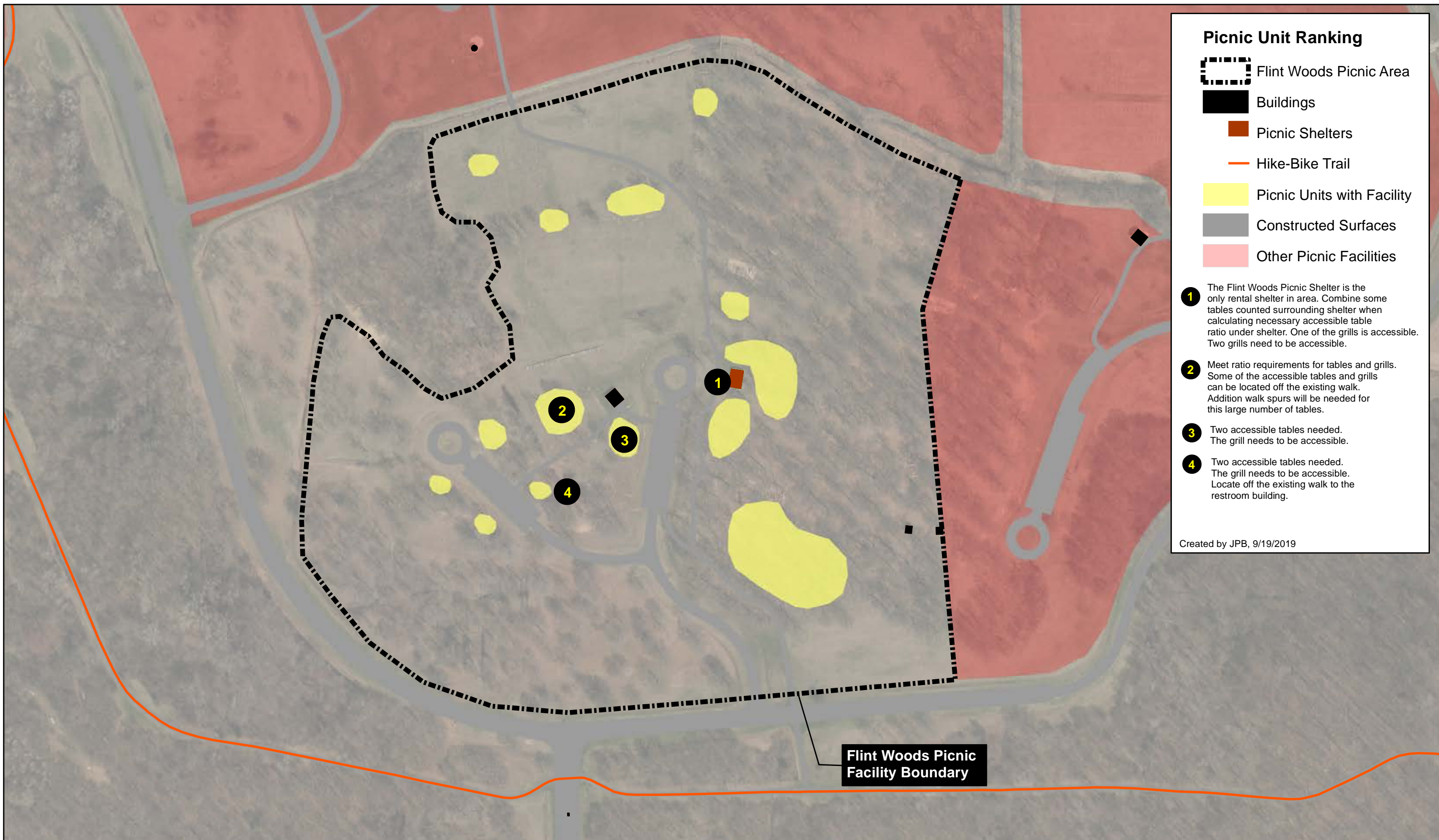

Picnic Unit Ranking

-  Flint Woods Picnic Area
-  Buildings
-  Picnic Shelters
-  Hike-Bike Trail
-  Picnic Units with Facility
-  Constructed Surfaces
-  Other Picnic Facilities

- 1** The Flint Woods Picnic Shelter is the only rental shelter in area. Combine some tables counted surrounding shelter when calculating necessary accessible table ratio under shelter. One of the grills is accessible. Two grills need to be accessible.
- 2** Meet ratio requirements for tables and grills. Some of the accessible tables and grills can be located off the existing walk. Addition walk spurs will be needed for this large number of tables.
- 3** Two accessible tables needed. The grill needs to be accessible.
- 4** Two accessible tables needed. The grill needs to be accessible. Locate off the existing walk to the restroom building.





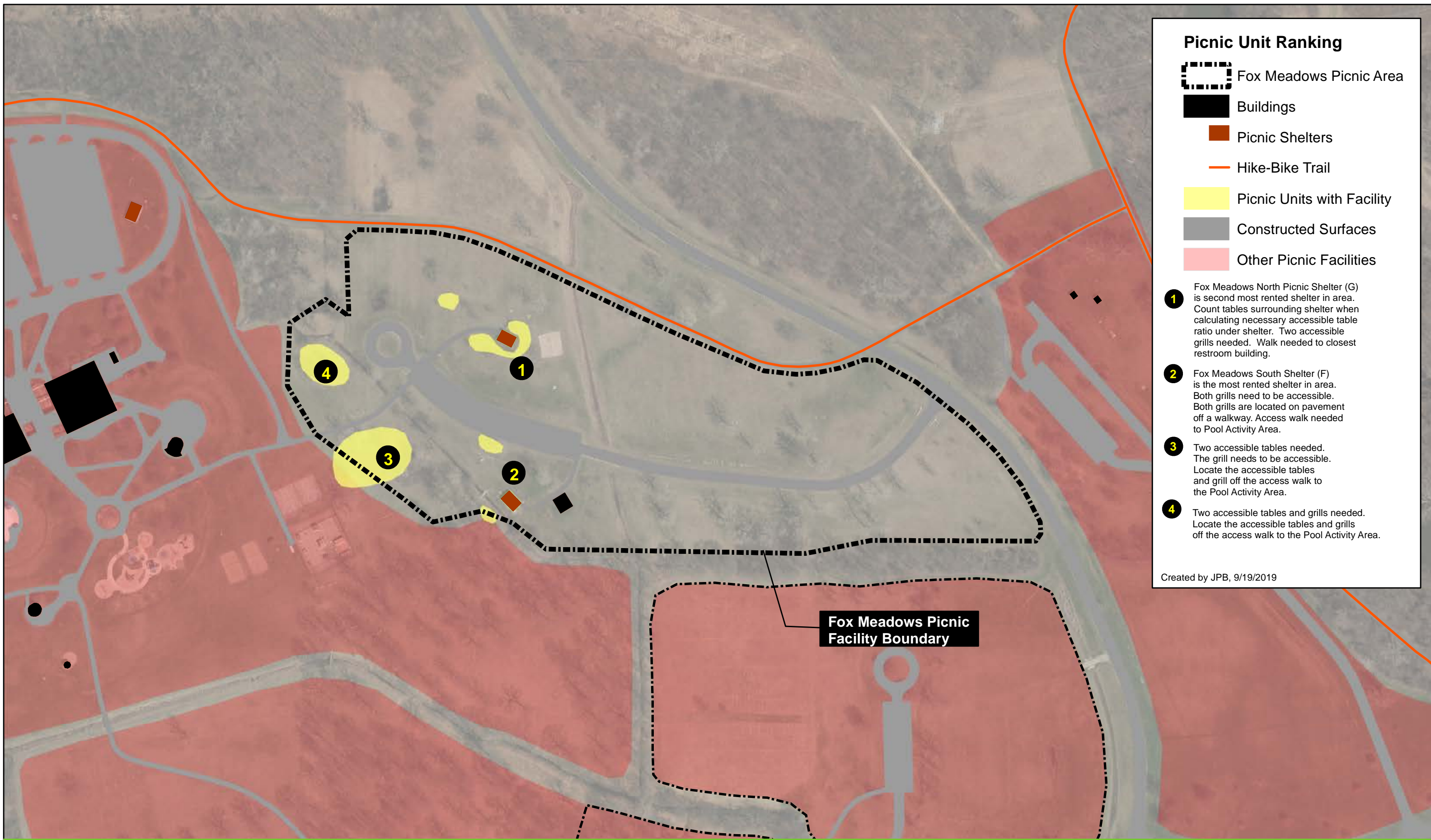

Created by JPB, 9/19/2019

Flint Woods Picnic Facility Boundary





Picnic Unit Ranking

-  Fox Meadows Picnic Area
-  Buildings
-  Picnic Shelters
-  Hike-Bike Trail
-  Picnic Units with Facility
-  Constructed Surfaces
-  Other Picnic Facilities

- 1** Fox Meadows North Picnic Shelter (G) is second most rented shelter in area. Count tables surrounding shelter when calculating necessary accessible table ratio under shelter. Two accessible grills needed. Walk needed to closest restroom building.
- 2** Fox Meadows South Shelter (F) is the most rented shelter in area. Both grills need to be accessible. Both grills are located on pavement off a walkway. Access walk needed to Pool Activity Area.
- 3** Two accessible tables needed. The grill needs to be accessible. Locate the accessible tables and grill off the access walk to the Pool Activity Area.
- 4** Two accessible tables and grills needed. Locate the accessible tables and grills off the access walk to the Pool Activity Area.

Created by JPB, 9/19/2019

Fox Meadows Picnic Facility Boundary

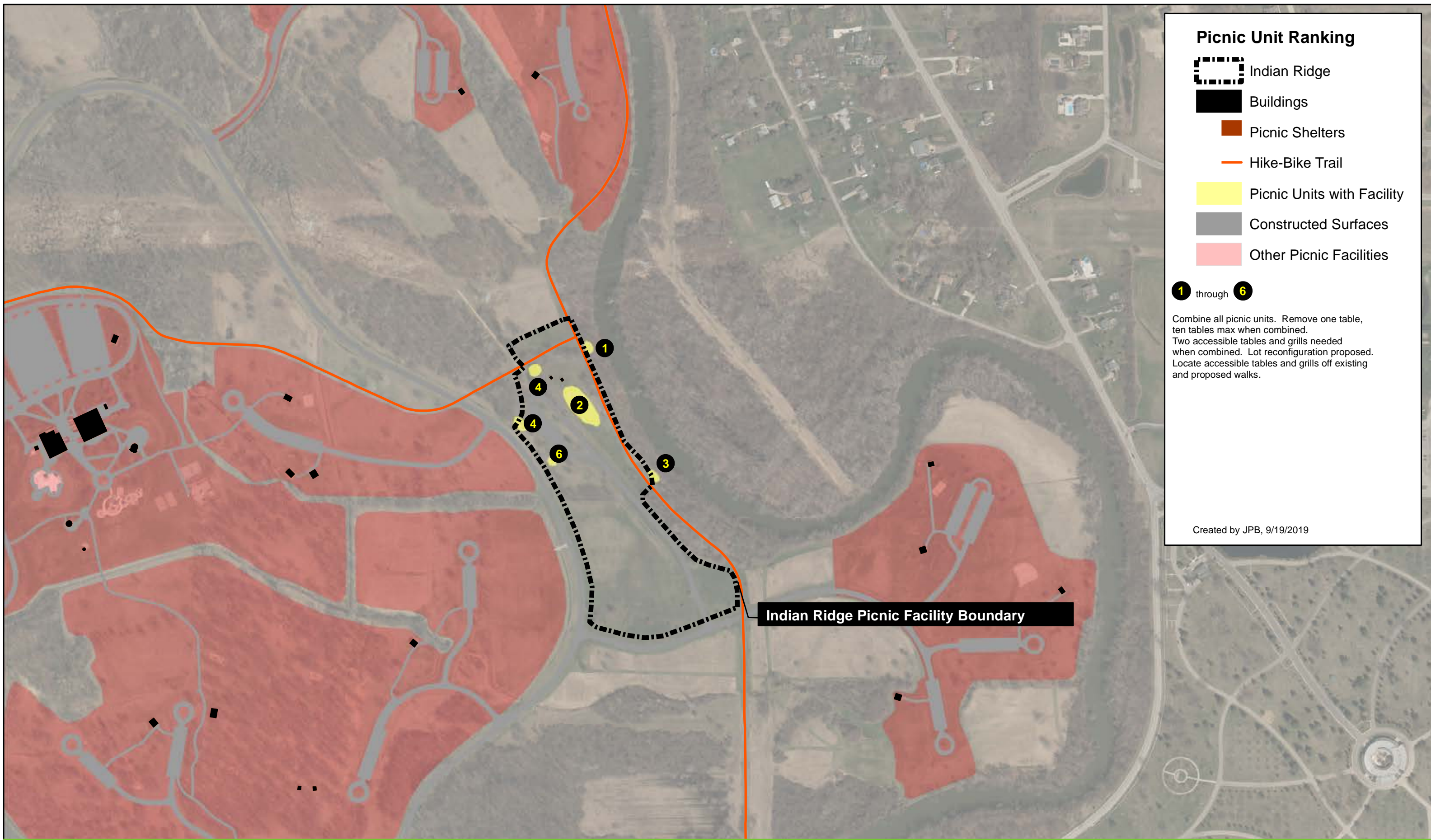

Picnic Unit Ranking

-  Indian Ridge
-  Buildings
-  Picnic Shelters
-  Hike-Bike Trail
-  Picnic Units with Facility
-  Constructed Surfaces
-  Other Picnic Facilities

1 through **6**





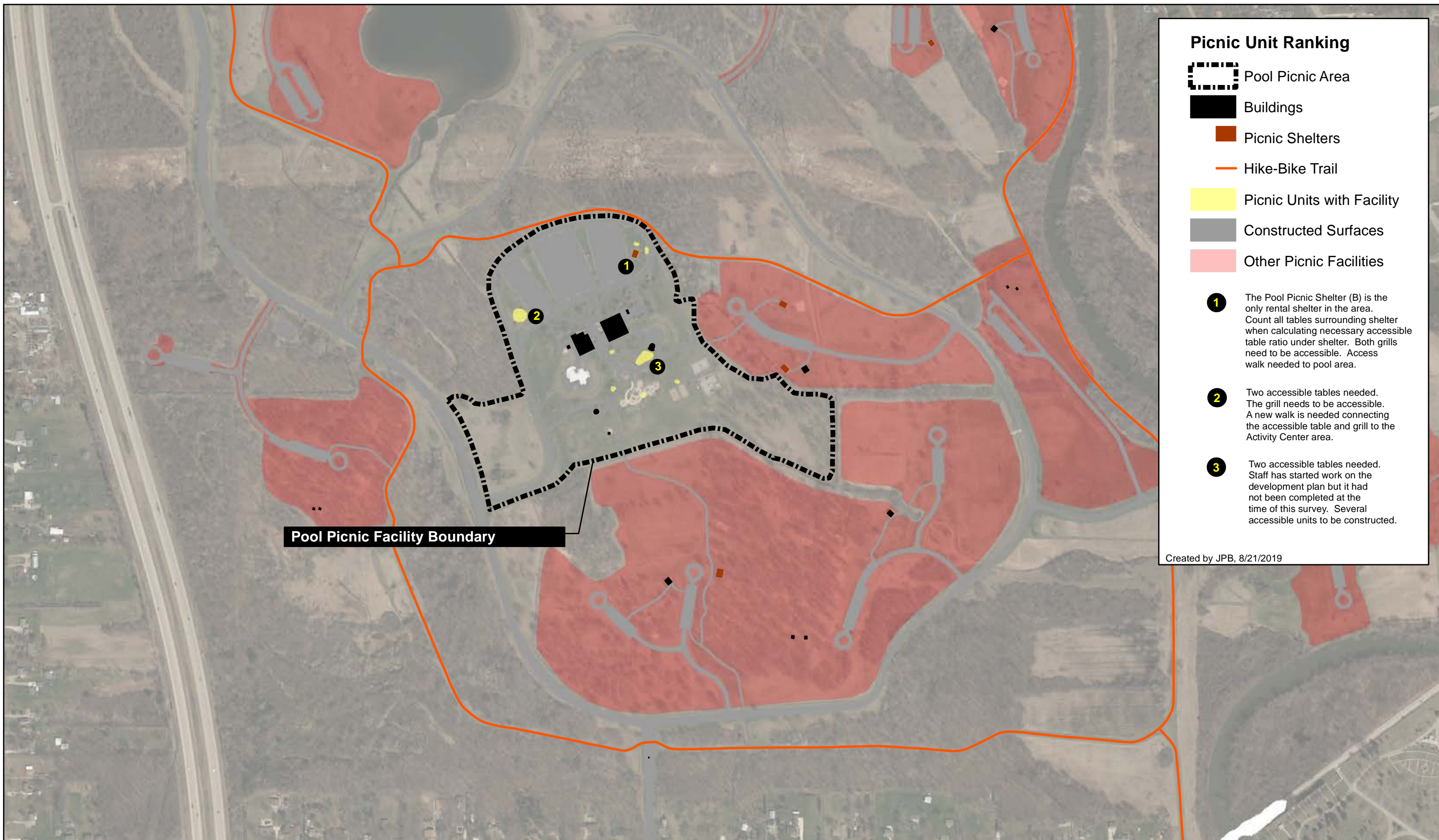

Combine all picnic units. Remove one table, ten tables max when combined.
 Two accessible tables and grills needed when combined. Lot reconfiguration proposed. Locate accessible tables and grills off existing and proposed walks.

Created by JPB, 9/19/2019

Indian Ridge Picnic Facility Boundary



Picnic Unit Ranking

-  Pool Picnic Area
-  Buildings
-  Picnic Shelters
-  Hike-Bike Trail
-  Picnic Units with Facility
-  Constructed Surfaces
-  Other Picnic Facilities





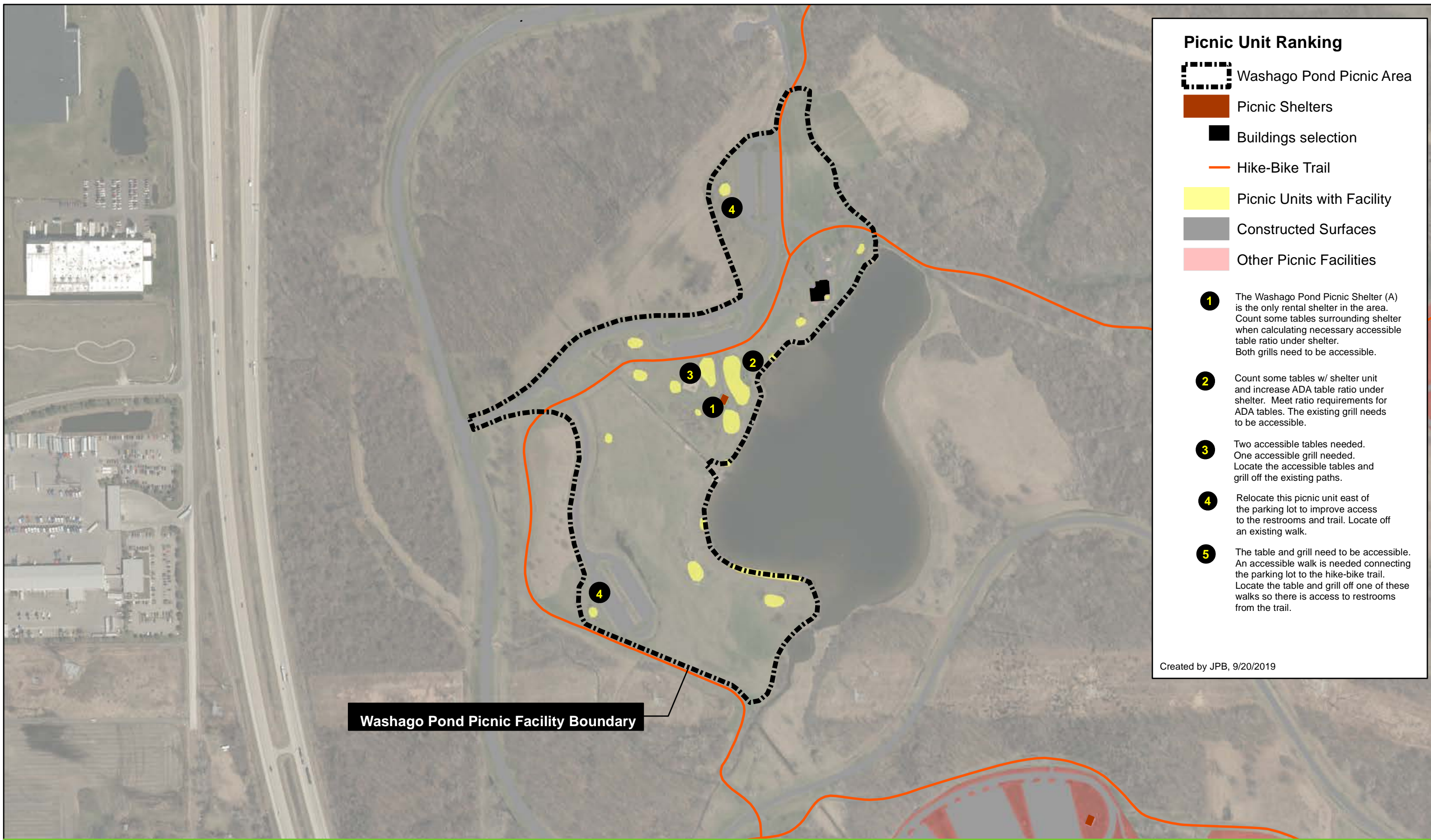

- 1** The Pool Picnic Shelter (B) is the only rental shelter in the area. Count all tables surrounding shelter when calculating necessary accessible table ratio under shelter. Both grills need to be accessible. Access walk needed to pool area.
- 2** Two accessible tables needed. The grill needs to be accessible. A new walk is needed connecting the accessible table and grill to the Activity Center area.
- 3** Two accessible tables needed. Staff has started work on the development plan but it had not been completed at the time of this survey. Several accessible units to be constructed.

Pool Picnic Facility Boundary

Created by JPB, 8/21/2019



Picnic Unit Ranking

-  Washago Pond Picnic Area
-  Picnic Shelters
-  Buildings selection
-  Hike-Bike Trail
-  Picnic Units with Facility
-  Constructed Surfaces
-  Other Picnic Facilities

- 1** The Washago Pond Picnic Shelter (A) is the only rental shelter in the area. Count some tables surrounding shelter when calculating necessary accessible table ratio under shelter. Both grills need to be accessible.
- 2** Count some tables w/ shelter unit and increase ADA table ratio under shelter. Meet ratio requirements for ADA tables. The existing grill needs to be accessible.
- 3** Two accessible tables needed. One accessible grill needed. Locate the accessible tables and grill off the existing paths.
- 4** Relocate this picnic unit east of the parking lot to improve access to the restrooms and trail. Locate off an existing walk.
- 5** The table and grill need to be accessible. An accessible walk is needed connecting the parking lot to the hike-bike trail. Locate the table and grill off one of these walks so there is access to restrooms from the trail.

Created by JPB, 9/20/2019

Washago Pond Picnic Facility Boundary

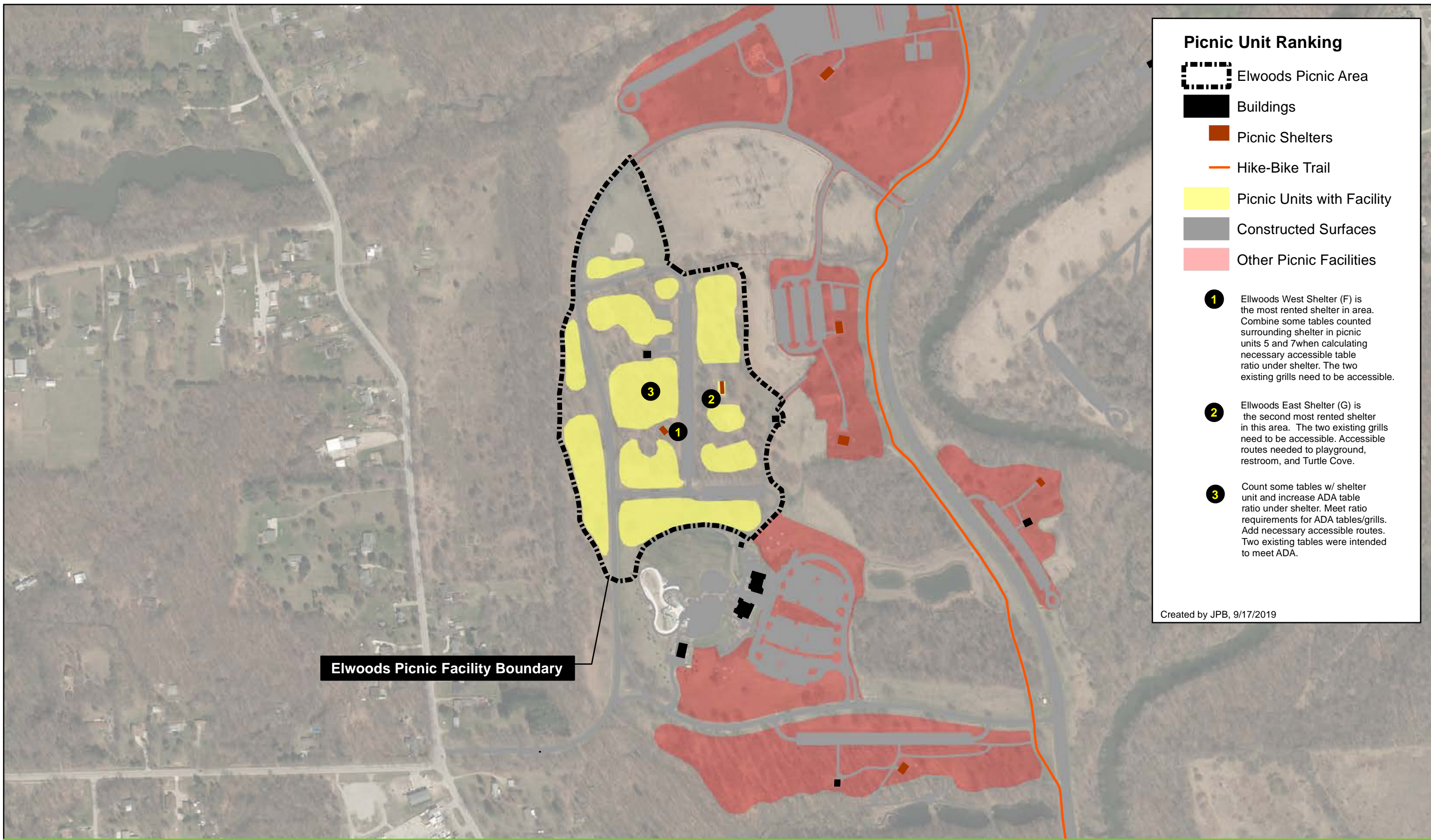

Picnic Unit Ranking

-  Elwoods Picnic Area
-  Buildings
-  Picnic Shelters
-  Hike-Bike Trail
-  Picnic Units with Facility
-  Constructed Surfaces
-  Other Picnic Facilities





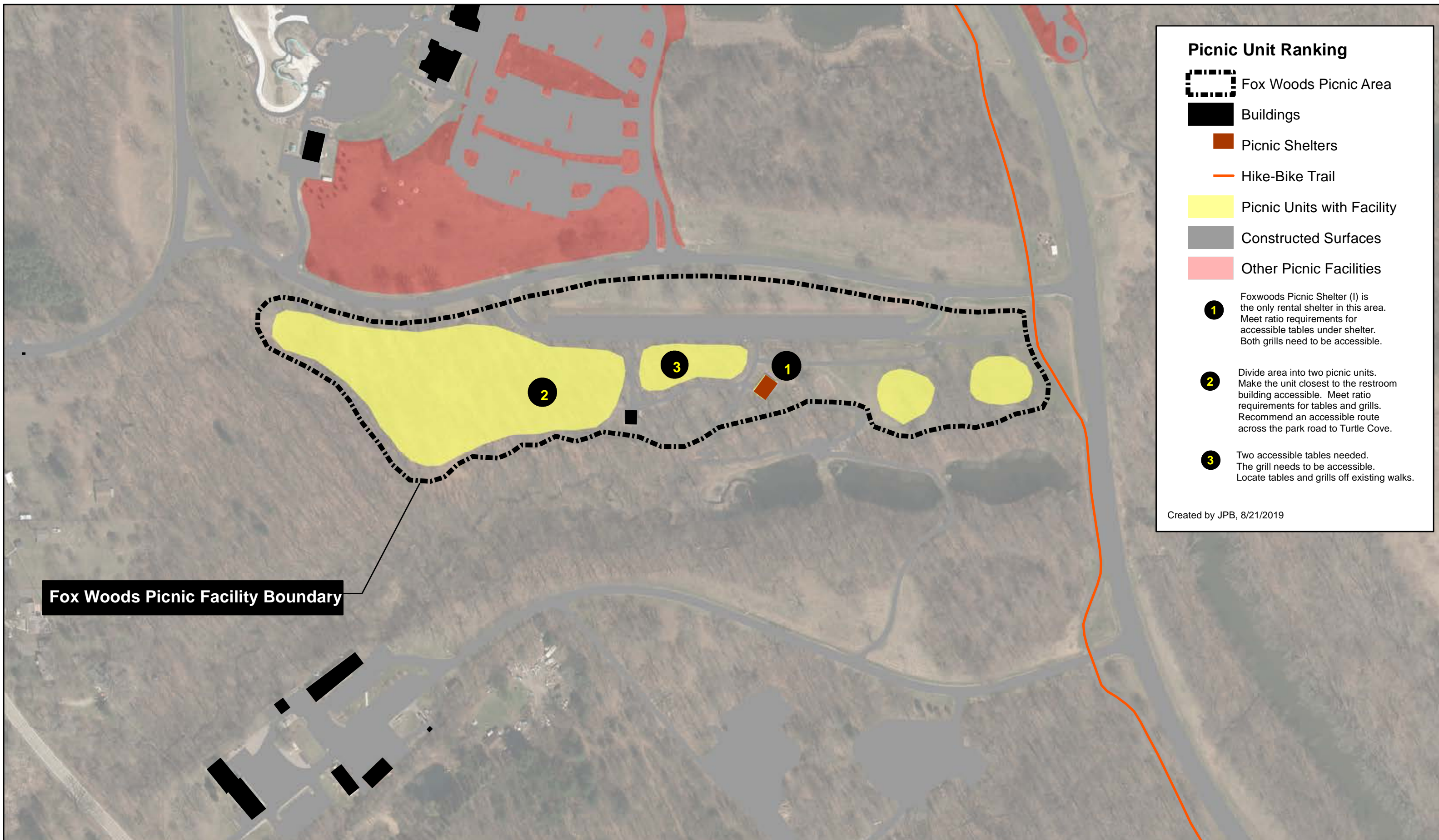

- 1** Elwoods West Shelter (F) is the most rented shelter in area. Combine some tables counted surrounding shelter in picnic units 5 and 7 when calculating necessary accessible table ratio under shelter. The two existing grills need to be accessible.
- 2** Elwoods East Shelter (G) is the second most rented shelter in this area. The two existing grills need to be accessible. Accessible routes needed to playground, restroom, and Turtle Cove.
- 3** Count some tables w/ shelter unit and increase ADA table ratio under shelter. Meet ratio requirements for ADA tables/grills. Add necessary accessible routes. Two existing tables were intended to meet ADA.

Created by JPB, 9/17/2019

Elwoods Picnic Facility Boundary



Picnic Unit Ranking

-  Fox Woods Picnic Area
-  Buildings
-  Picnic Shelters
-  Hike-Bike Trail
-  Picnic Units with Facility
-  Constructed Surfaces
-  Other Picnic Facilities

- 1** Foxwoods Picnic Shelter (1) is the only rental shelter in this area. Meet ratio requirements for accessible tables under shelter. Both grills need to be accessible.
- 2** Divide area into two picnic units. Make the unit closest to the restroom building accessible. Meet ratio requirements for tables and grills. Recommend an accessible route across the park road to Turtle Cove.
- 3** Two accessible tables needed. The grill needs to be accessible. Locate tables and grills off existing walks.





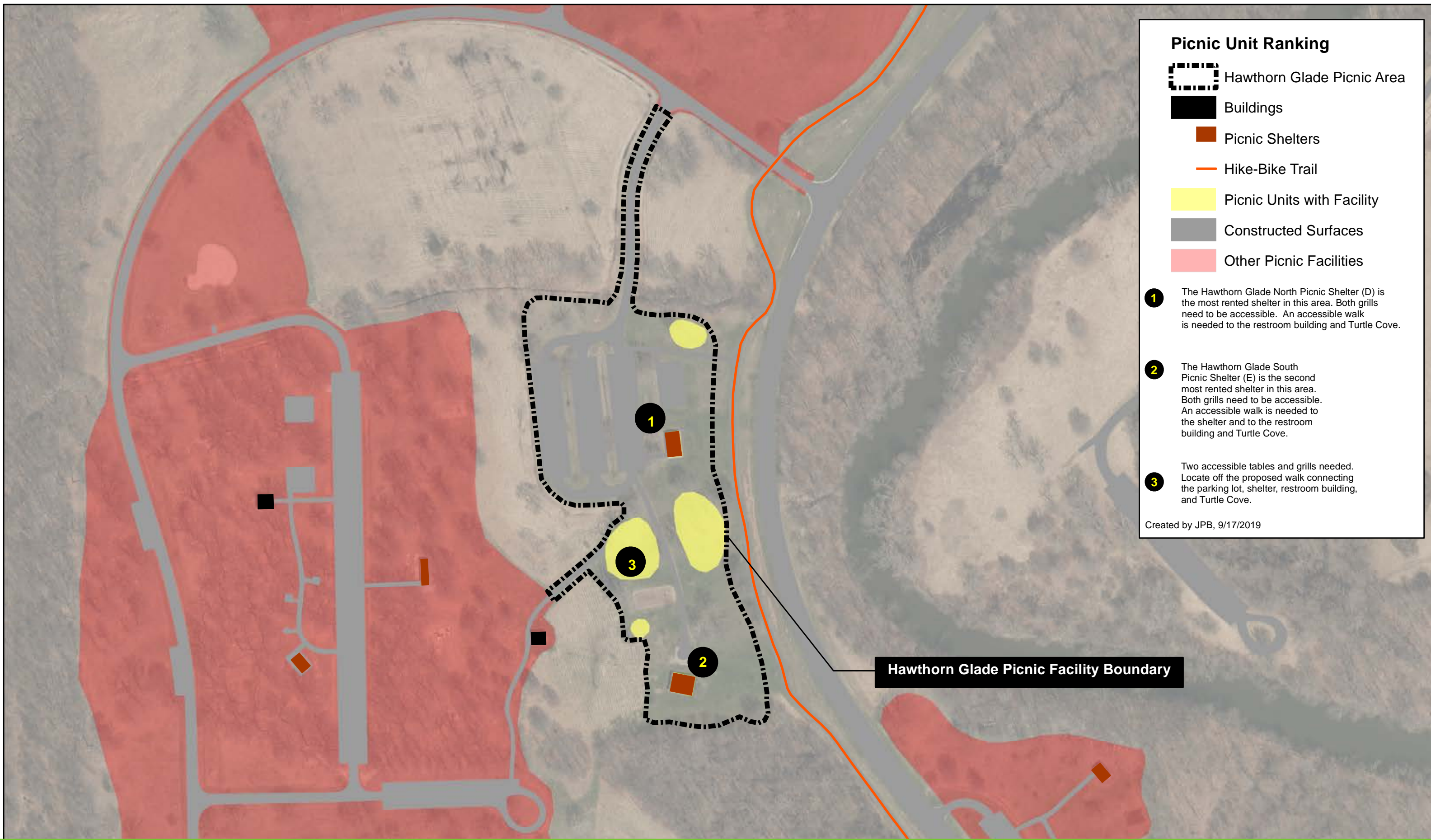

Created by JPB, 8/21/2019

Fox Woods Picnic Facility Boundary





Picnic Unit Ranking

-  Hawthorn Glade Picnic Area
-  Buildings
-  Picnic Shelters
-  Hike-Bike Trail
-  Picnic Units with Facility
-  Constructed Surfaces
-  Other Picnic Facilities

- 1** The Hawthorn Glade North Picnic Shelter (D) is the most rented shelter in this area. Both grills need to be accessible. An accessible walk is needed to the restroom building and Turtle Cove.
- 2** The Hawthorn Glade South Picnic Shelter (E) is the second most rented shelter in this area. Both grills need to be accessible. An accessible walk is needed to the shelter and to the restroom building and Turtle Cove.
- 3** Two accessible tables and grills needed. Locate off the proposed walk connecting the parking lot, shelter, restroom building, and Turtle Cove.

Created by JPB, 9/17/2019

Hawthorn Glade Picnic Facility Boundary

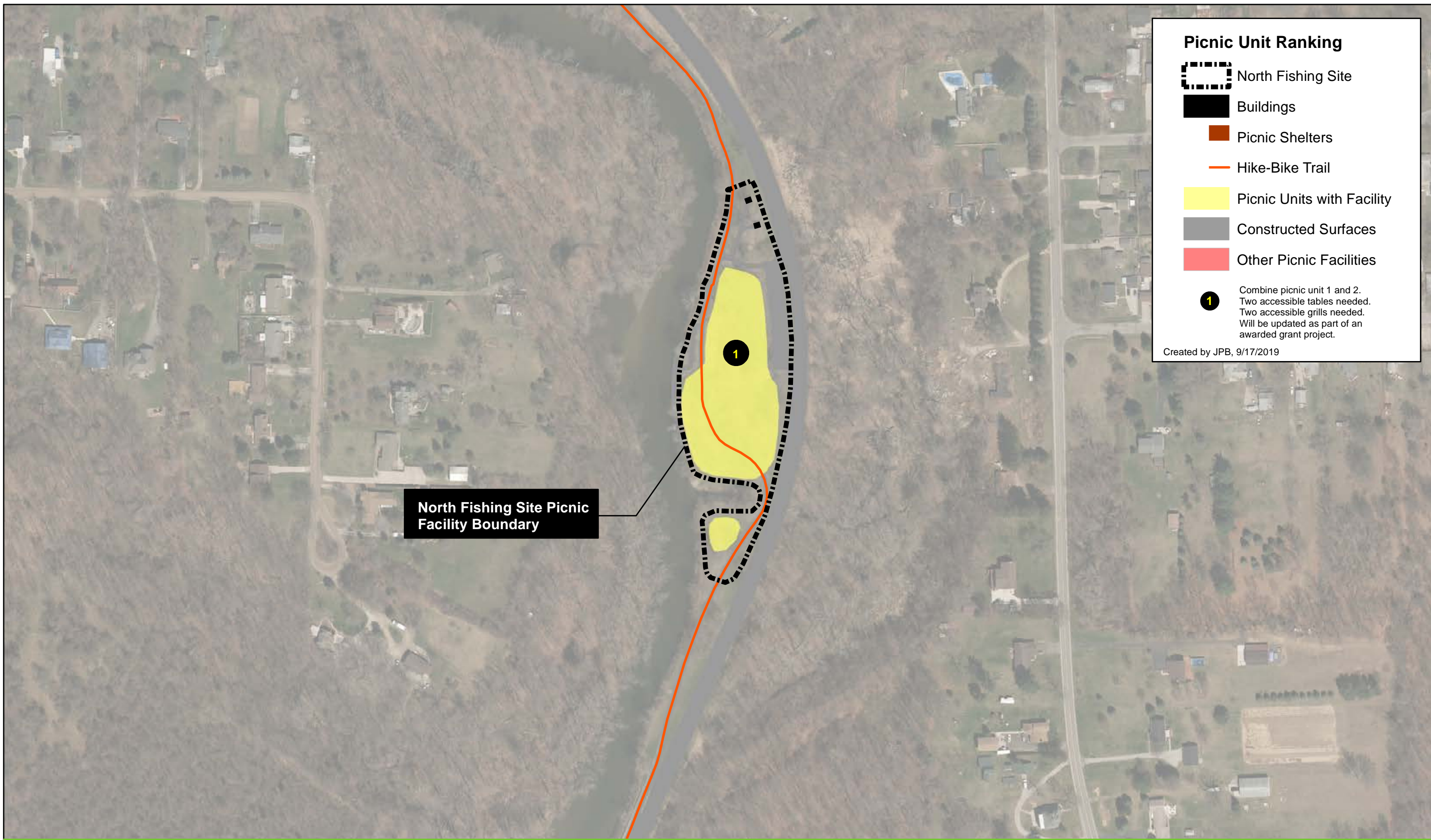

Picnic Unit Ranking

-  North Fishing Site
-  Buildings
-  Picnic Shelters
-  Hike-Bike Trail
-  Picnic Units with Facility
-  Constructed Surfaces
-  Other Picnic Facilities

-  Combine picnic unit 1 and 2.
Two accessible tables needed.
Two accessible grills needed.
Will be updated as part of an awarded grant project.

Created by JPB, 9/17/2019



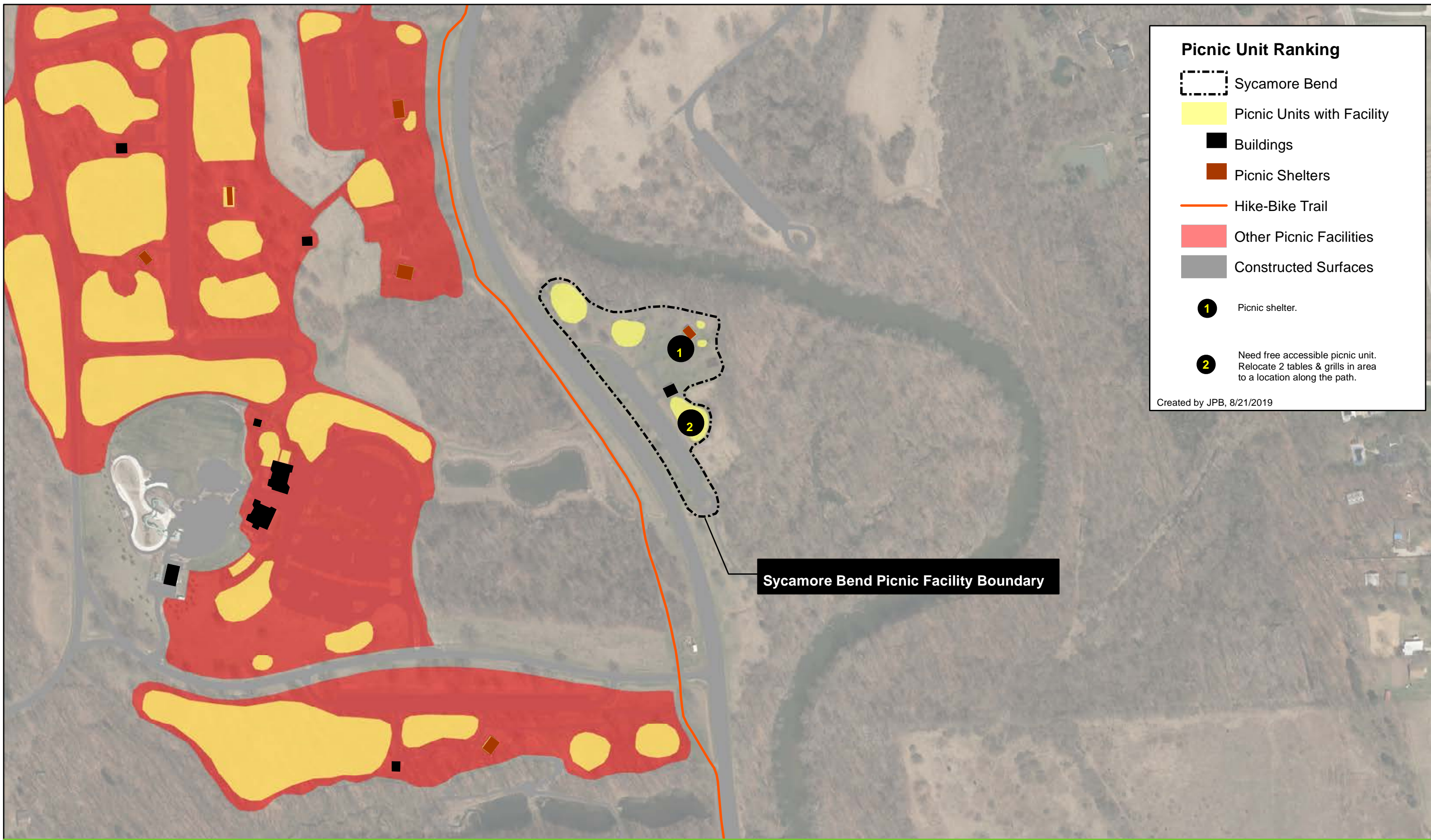

Picnic Unit Ranking

-  Sycamore Bend
-  Picnic Units with Facility
-  Buildings
-  Picnic Shelters
-  Hike-Bike Trail
-  Other Picnic Facilities
-  Constructed Surfaces
-  Picnic shelter.
-  Need free accessible picnic unit. Relocate 2 tables & grills in area to a location along the path.

Created by JPB, 8/21/2019

Sycamore Bend Picnic Facility Boundary

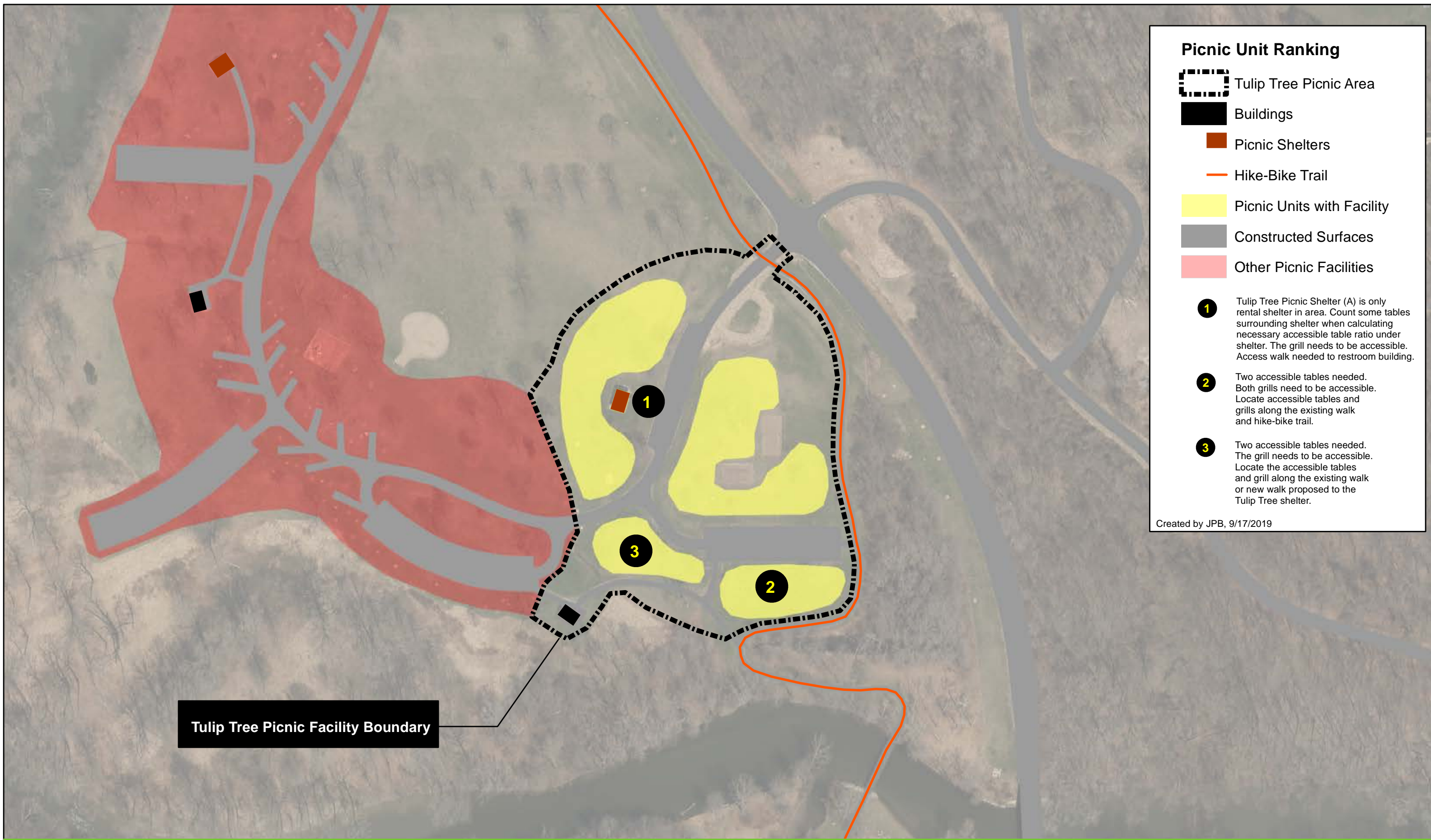

Picnic Unit Ranking

Tulip Tree Picnic Area

Buildings

Picnic Shelters

Hike-Bike Trail

Picnic Units with Facility

Constructed Surfaces

Other Picnic Facilities

1 Tulip Tree Picnic Shelter (A) is only rental shelter in area. Count some tables surrounding shelter when calculating necessary accessible table ratio under shelter. The grill needs to be accessible. Access walk needed to restroom building.

2 Two accessible tables needed. Both grills need to be accessible. Locate accessible tables and grills along the existing walk and hike-bike trail.

3 Two accessible tables needed. The grill needs to be accessible. Locate the accessible tables and grill along the existing walk or new walk proposed to the Tulip Tree shelter.

Created by JPB, 9/17/2019

Tulip Tree Picnic Facility Boundary



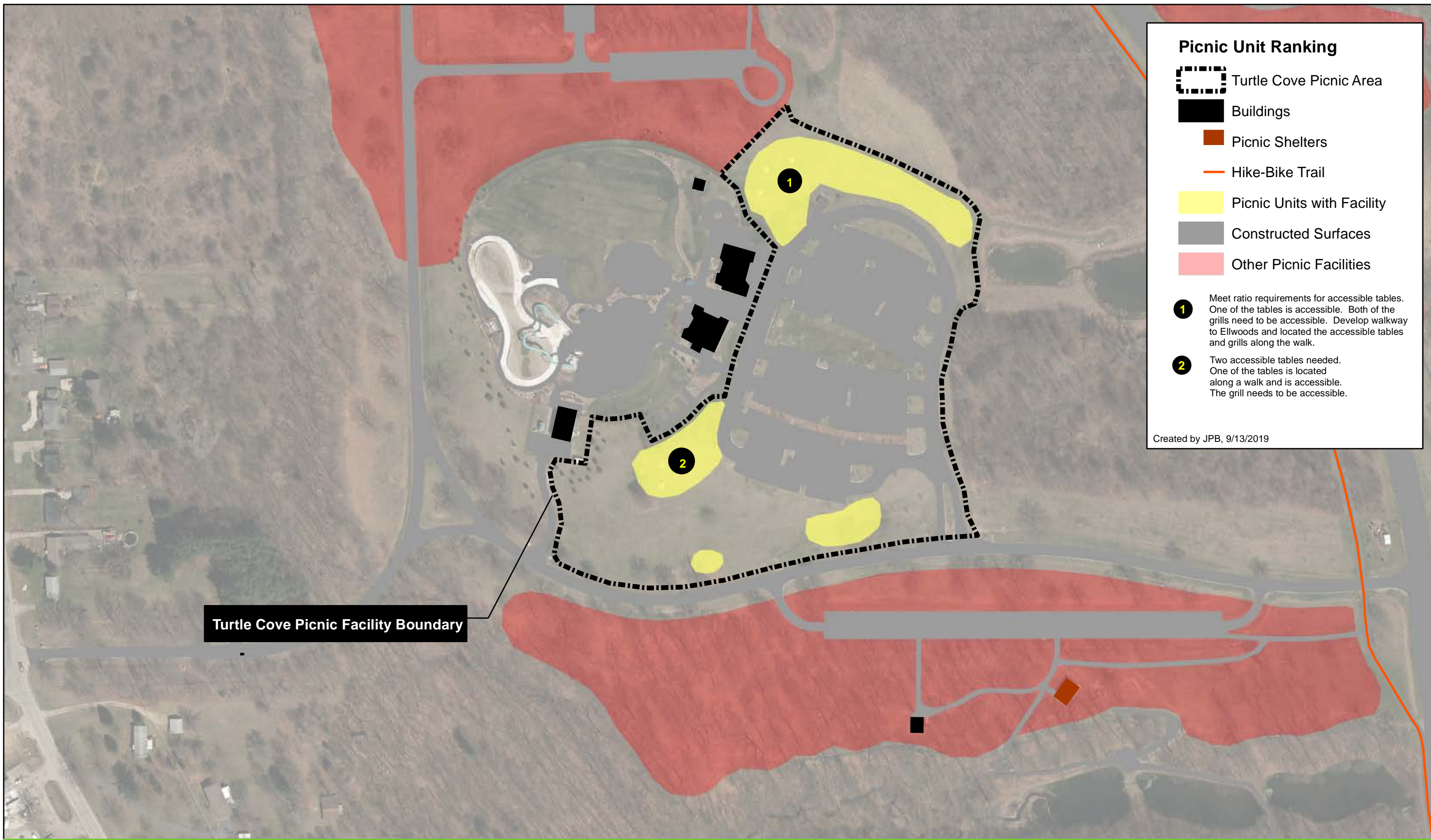

Picnic Unit Ranking

-  Turtle Cove Picnic Area
-  Buildings
-  Picnic Shelters
-  Hike-Bike Trail
-  Picnic Units with Facility
-  Constructed Surfaces
-  Other Picnic Facilities

- 1** Meet ratio requirements for accessible tables. One of the tables is accessible. Both of the grills need to be accessible. Develop walkway to Ellwoods and located the accessible tables and grills along the walk.
- 2** Two accessible tables needed. One of the tables is located along a walk and is accessible. The grill needs to be accessible.







Created by JPB, 9/13/2019

Turtle Cove Picnic Facility Boundary





Picnic Unit Ranking

-  Woods Creek Picnic Area
-  Buildings
-  Picnic Shelters
-  Hike-Bike Trail
-  Picnic Units with Facility
-  Constructed Surfaces
-  Other Picnic Facilities





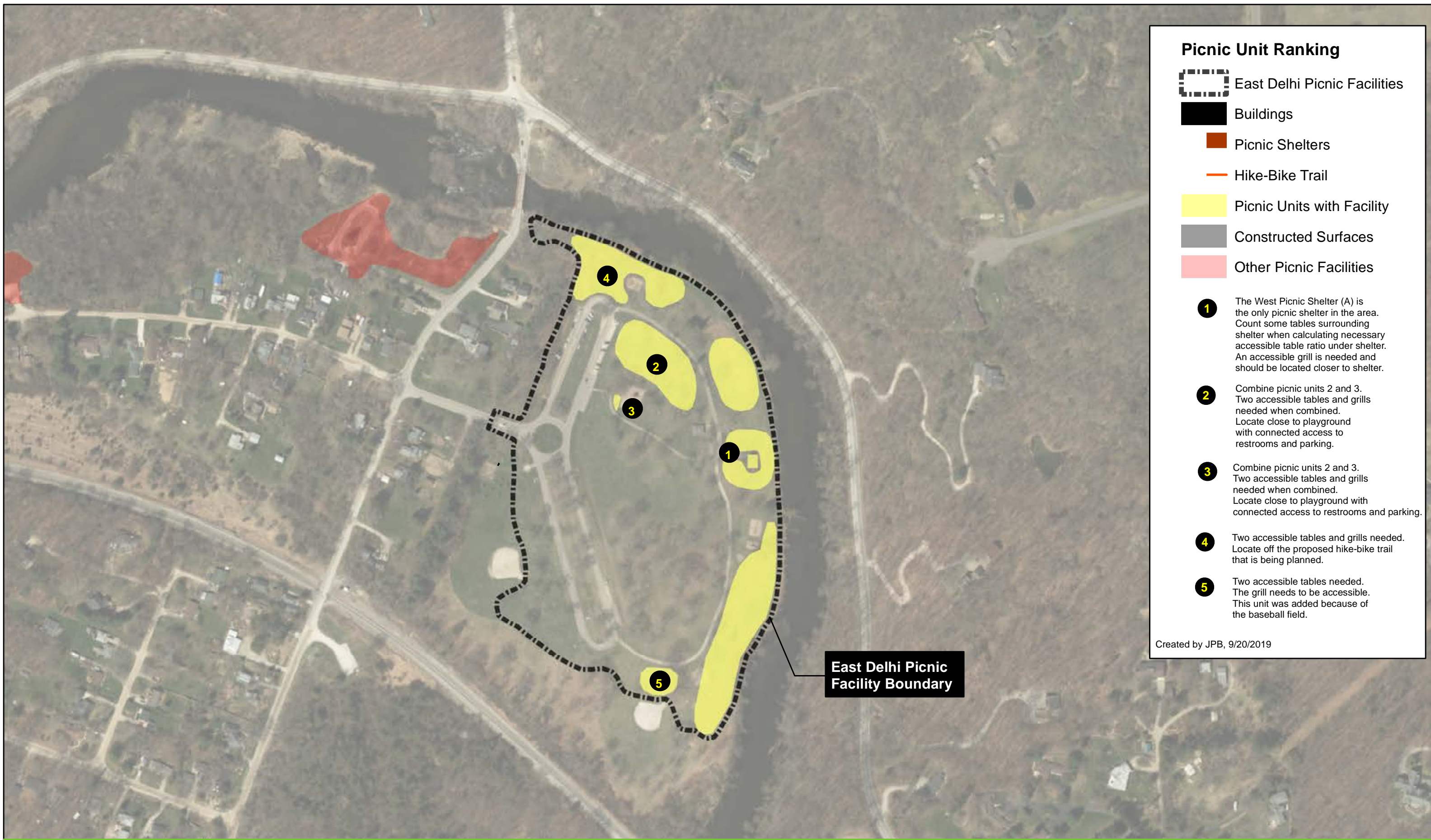

- 1** Woods Creek South Shelter (C) is the most rented shelter in this area. Meet ratio requirements for accessible tables under shelter. The two existing grills need to be accessible, both are located on pavement along an accessible route.
- 2** Woods Creek North Shelter (B) is the second most rented shelter in this area. Two accessible tables needed. Both grills need to be accessible.
- 3** Leave as is, won't be an accessible picnic unit.
- 4** Count some tables w/ shelter unit and increase ADA table ratio under shelter. Locate accessible tables and grills off the existing path. Has an accessible route to restrooms through parking lot.

Created by JPB, 9/17/2019

Woods Creek Picnic Facility Boundary



Picnic Unit Ranking

-  East Delhi Picnic Facilities
-  Buildings
-  Picnic Shelters
-  Hike-Bike Trail
-  Picnic Units with Facility
-  Constructed Surfaces
-  Other Picnic Facilities

- 1** The West Picnic Shelter (A) is the only picnic shelter in the area. Count some tables surrounding shelter when calculating necessary accessible table ratio under shelter. An accessible grill is needed and should be located closer to shelter.
- 2** Combine picnic units 2 and 3. Two accessible tables and grills needed when combined. Locate close to playground with connected access to restrooms and parking.
- 3** Combine picnic units 2 and 3. Two accessible tables and grills needed when combined. Locate close to playground with connected access to restrooms and parking.
- 4** Two accessible tables and grills needed. Locate off the proposed hike-bike trail that is being planned.
- 5** Two accessible tables needed. The grill needs to be accessible. This unit was added because of the baseball field.

Created by JPB, 9/20/2019

East Delhi Picnic Facility Boundary

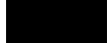

Picnic Unit Ranking

-  West Delhi Picnic Area
-  Buildings
-  Picnic Shelters
-  Hike-Bike Trail
-  Picnic Units with Facility
-  Constructed Surfaces
-  Other Picnic Facilities

1 and **2**

Combine both units at West Delhi. Two accessible tables and two accessible grills needed when combined. Locate off the proposed hike-bike trail that is being planned. Accessible route needed to vault latrines.

Created by JPB, 9/20/2019

West Delhi Picnic Facility Boundary





Picnic Unit Ranking

-  Dexter-Huron East Picnic Area
-  Buildings
-  Picnic Shelters
-  Hike-Bike Trail
-  Picnic Units with Facility
-  Constructed Surfaces
-  Other Picnic Facilities

- 1** The Central Picnic Shelter (B) is the most rented shelter on this side of the park. Count some of the tables from picnic unit 7 when calculating necessary accessible table ratio under shelter. An accessible grill is needed close to the shelter.
- 2** The East Picnic Shelter (C) is the second most rented shelter on this side of the park. An access walk is needed to the shelter. An accessible grill is needed close to the shelter.
- 3** Count some tables w/ shelter unit and increase ADA table ratio under shelter. Two accessible tables and grills needed. A Natural Rivers Permit will be required.
- 4** Two accessible tables and grills needed. Locate off new walk to be constructed to the East Shelter. Natural Rivers permit will be required.





Created by JPB, 9/20/2019

Dexter-Huron East Picnic Facility Boundary



Dexter-Huron West Picnic Facility Boundary

Picnic Unit Ranking







-  Dexter-Huron Picnic Area
-  Buildings
-  Picnic Shelters
-  Hike-Bike Trail
-  Picnic Units with Facility
-  Constructed Surfaces
-  Other Picnic Facilities

- 1** The West Picnic Shelter (A) is the most rented shelter on this side of park. Count all tables from unit 4 when calculating necessary accessible table ratio under shelter. Two long tables were counted as 6. Accessible grill needed close to shelter.
- 2** Two accessible tables and grills needed. Locate off the hike-bike trail. Natural Rivers Permit required.
- 3** Two accessible tables and grills needed. Locate off the new walk (Iron Belle Trail Grant) to be constructed from the west parking lot. A Natural Rivers Permit will be required.

Created by JPB, 9/20/2019



Picnic Unit Ranking

-  Acorn Ridge Picnic Facility
-  Picnic Shelters
-  Buildings
-  Hike-Bike Trail
-  Picnic Units with Facility
-  Constructed Surfaces
-  Other Picnic Facilities

- 1** The Acorn Ridge Picnic Shelter (B) is the only shelter in area. Count some tables from picnic unit 2 when calculating necessary accessible table ratio under shelter. An accessible grill is needed close to shelter. Accessible walks needed.
- 2** Count some tables w/ shelter unit and increase ADA table ratio under shelter. Divide picnic unit into 2 and make both units accessible with proper ratios. Locate accessible tables and grills off a new walk to the shelter and restroom building.





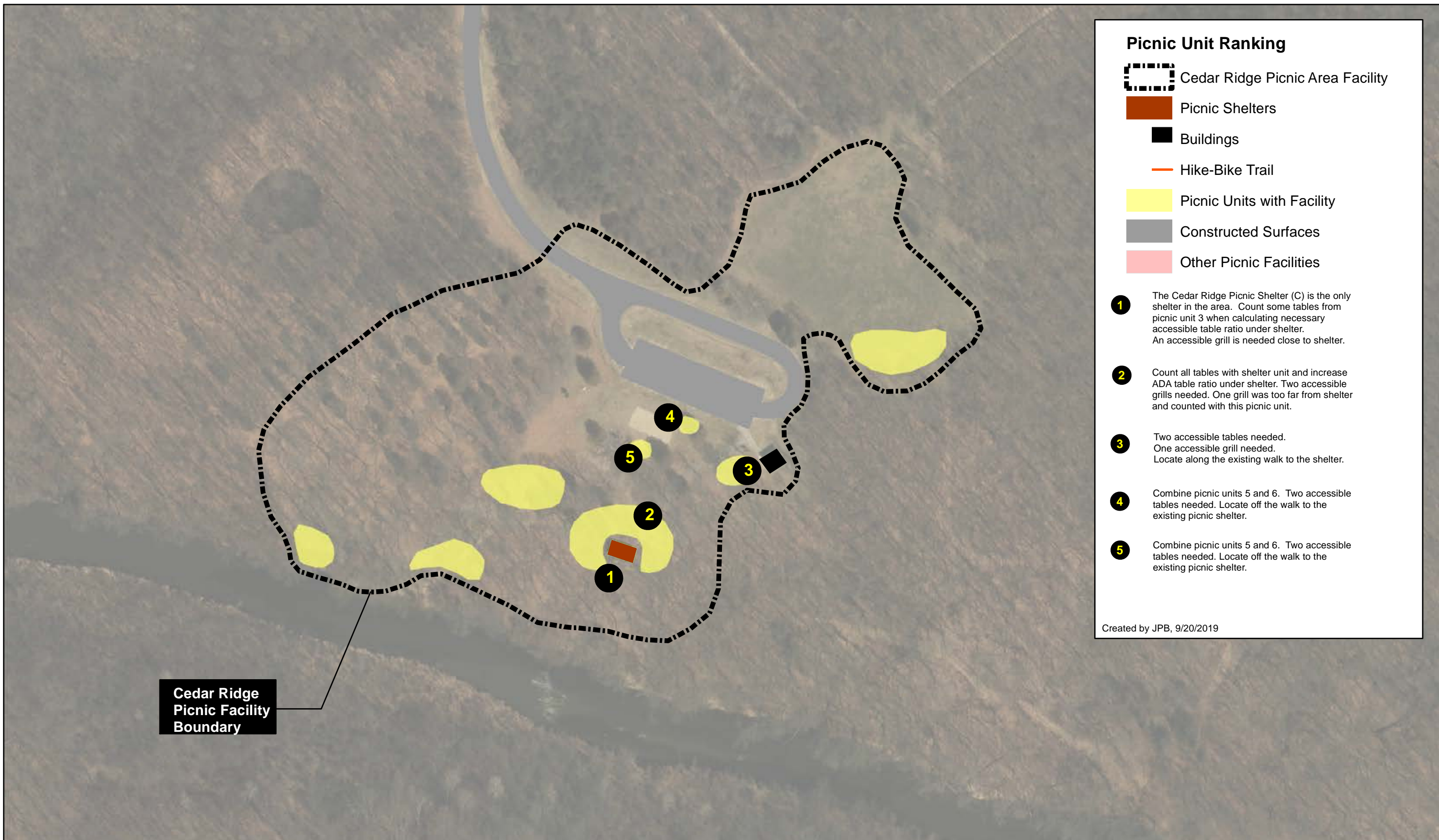

Created by JPB, 9/20/2019

Acorn Ridge
Picnic Facility
Boundary





Picnic Unit Ranking

-  Cedar Ridge Picnic Area Facility
-  Picnic Shelters
-  Buildings
-  Hike-Bike Trail
-  Picnic Units with Facility
-  Constructed Surfaces
-  Other Picnic Facilities





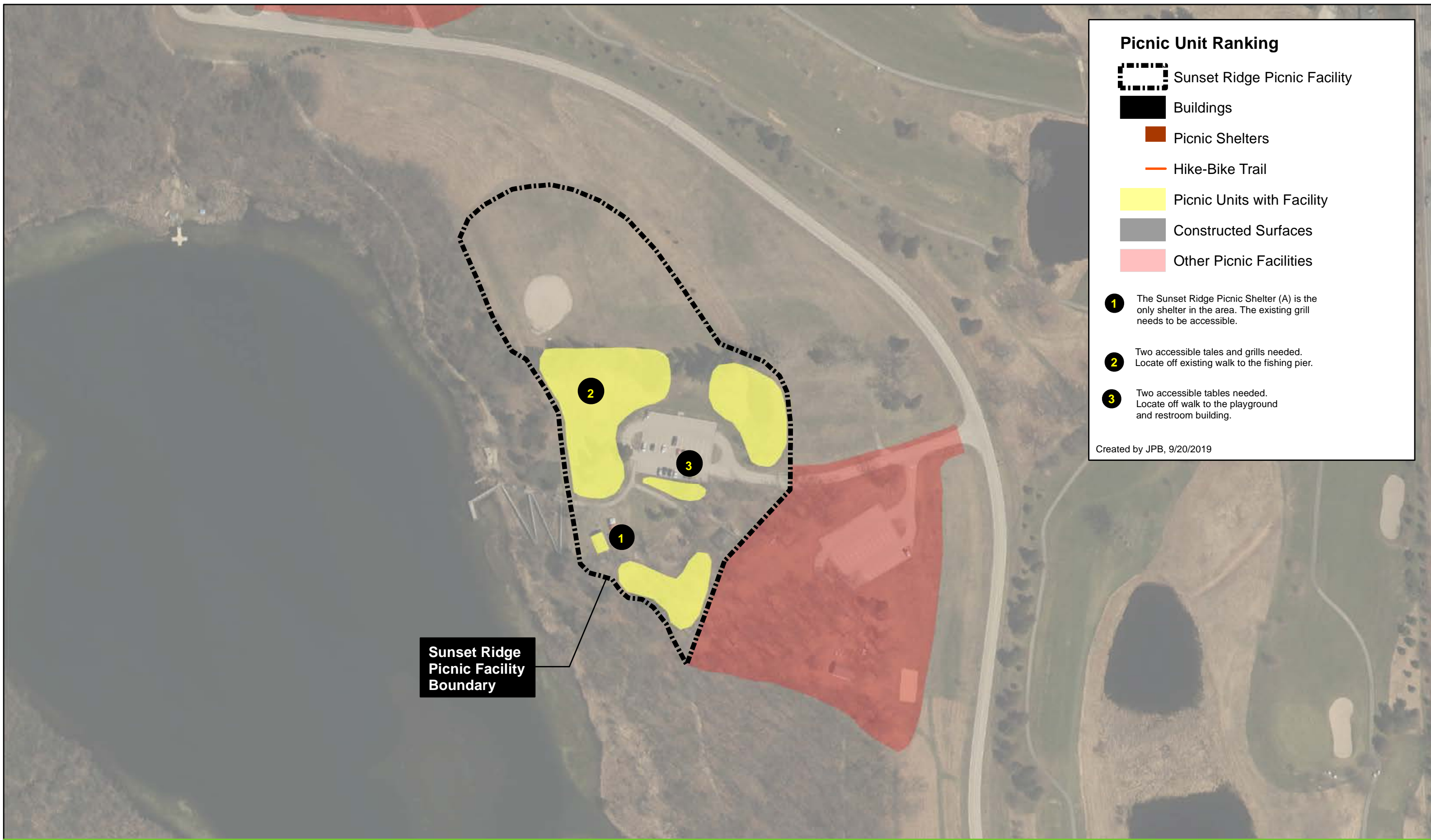

- 1** The Cedar Ridge Picnic Shelter (C) is the only shelter in the area. Count some tables from picnic unit 3 when calculating necessary accessible table ratio under shelter. An accessible grill is needed close to shelter.
- 2** Count all tables with shelter unit and increase ADA table ratio under shelter. Two accessible grills needed. One grill was too far from shelter and counted with this picnic unit.
- 3** Two accessible tables needed. One accessible grill needed. Locate along the existing walk to the shelter.
- 4** Combine picnic units 5 and 6. Two accessible tables needed. Locate off the walk to the existing picnic shelter.
- 5** Combine picnic units 5 and 6. Two accessible tables needed. Locate off the walk to the existing picnic shelter.

Created by JPB, 9/20/2019

Cedar Ridge
Picnic Facility
Boundary



Picnic Unit Ranking

-  Sunset Ridge Picnic Facility
-  Buildings
-  Picnic Shelters
-  Hike-Bike Trail
-  Picnic Units with Facility
-  Constructed Surfaces
-  Other Picnic Facilities





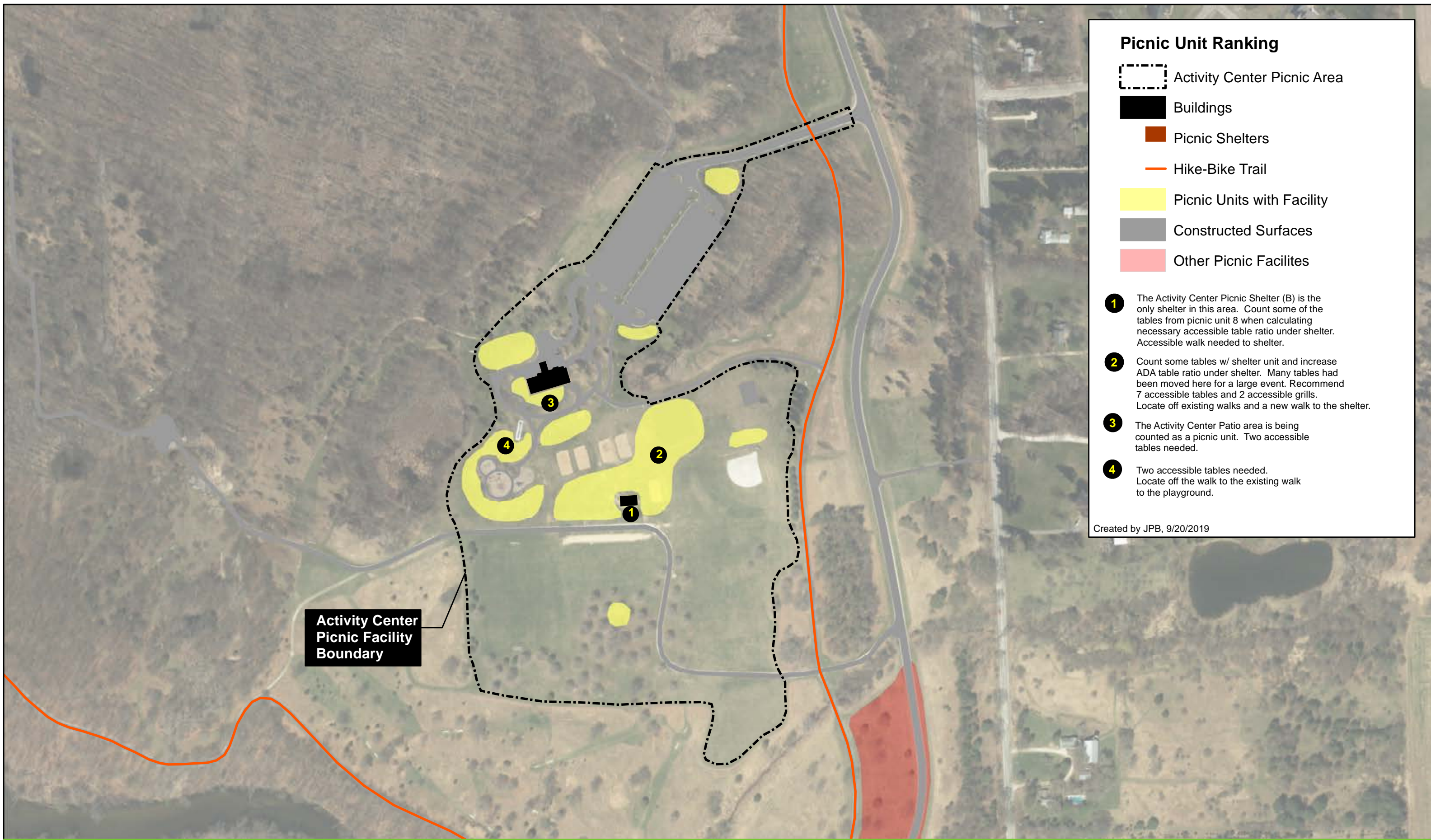

- 1** The Sunset Ridge Picnic Shelter (A) is the only shelter in the area. The existing grill needs to be accessible.
- 2** Two accessible tables and grills needed. Locate off existing walk to the fishing pier.
- 3** Two accessible tables needed. Locate off walk to the playground and restroom building.

Created by JPB, 9/20/2019

Sunset Ridge Picnic Facility Boundary



Picnic Unit Ranking

-  Activity Center Picnic Area
-  Buildings
-  Picnic Shelters
-  Hike-Bike Trail
-  Picnic Units with Facility
-  Constructed Surfaces
-  Other Picnic Facilities



- 1** The Activity Center Picnic Shelter (B) is the only shelter in this area. Count some of the tables from picnic unit 8 when calculating necessary accessible table ratio under shelter. Accessible walk needed to shelter.
- 2** Count some tables w/ shelter unit and increase ADA table ratio under shelter. Many tables had been moved here for a large event. Recommend 7 accessible tables and 2 accessible grills. Locate off existing walks and a new walk to the shelter.
- 3** The Activity Center Patio area is being counted as a picnic unit. Two accessible tables needed.
- 4** Two accessible tables needed. Locate off the walk to the existing walk to the playground.

Created by JPB, 9/20/2019

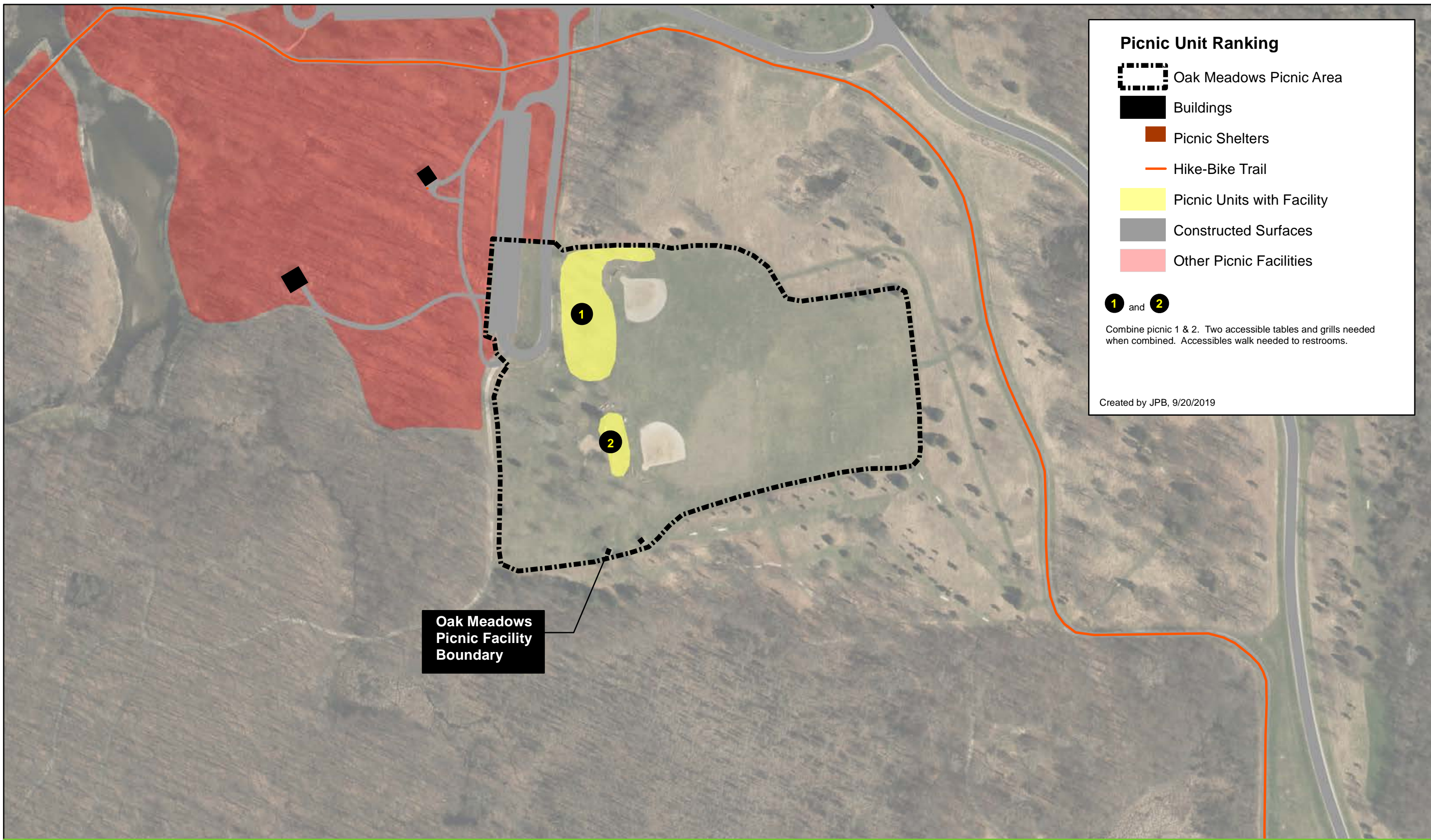
**Activity Center
Picnic Facility
Boundary**



Picnic Unit Ranking

-  Oak Meadows Picnic Area
-  Buildings
-  Picnic Shelters
-  Hike-Bike Trail
-  Picnic Units with Facility
-  Constructed Surfaces
-  Other Picnic Facilities

1 and **2**

Combine picnic 1 & 2. Two accessible tables and grills needed when combined. Accessible walk needed to restrooms.





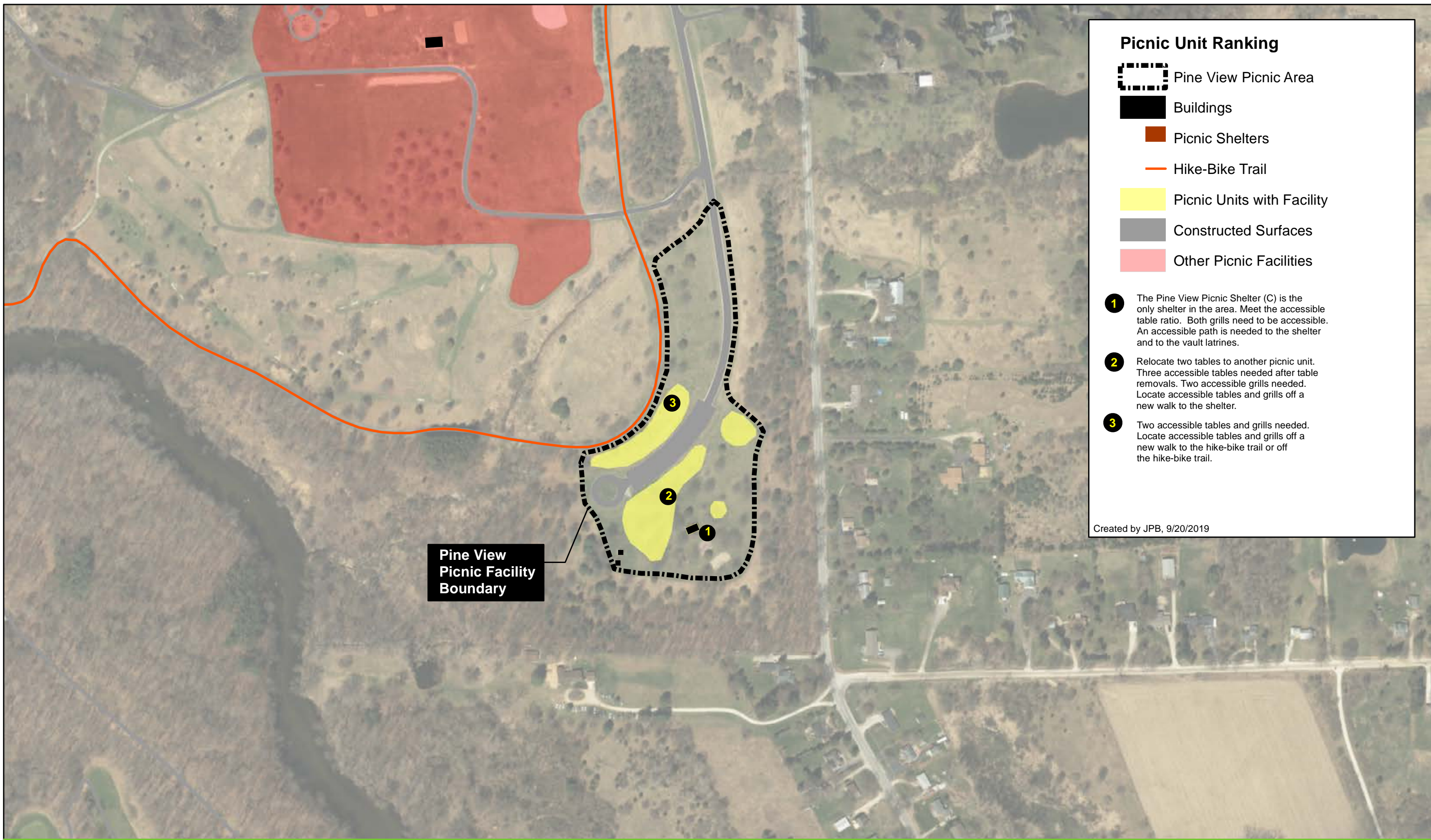

Created by JPB, 9/20/2019

Oak Meadows
Picnic Facility
Boundary





Picnic Unit Ranking

-  Pine View Picnic Area
-  Buildings
-  Picnic Shelters
-  Hike-Bike Trail
-  Picnic Units with Facility
-  Constructed Surfaces
-  Other Picnic Facilities

- 1** The Pine View Picnic Shelter (C) is the only shelter in the area. Meet the accessible table ratio. Both grills need to be accessible. An accessible path is needed to the shelter and to the vault latrines.
- 2** Relocate two tables to another picnic unit. Three accessible tables needed after table removals. Two accessible grills needed. Locate accessible tables and grills off a new walk to the shelter.
- 3** Two accessible tables and grills needed. Locate accessible tables and grills off a new walk to the hike-bike trail or off the hike-bike trail.

Created by JPB, 9/20/2019



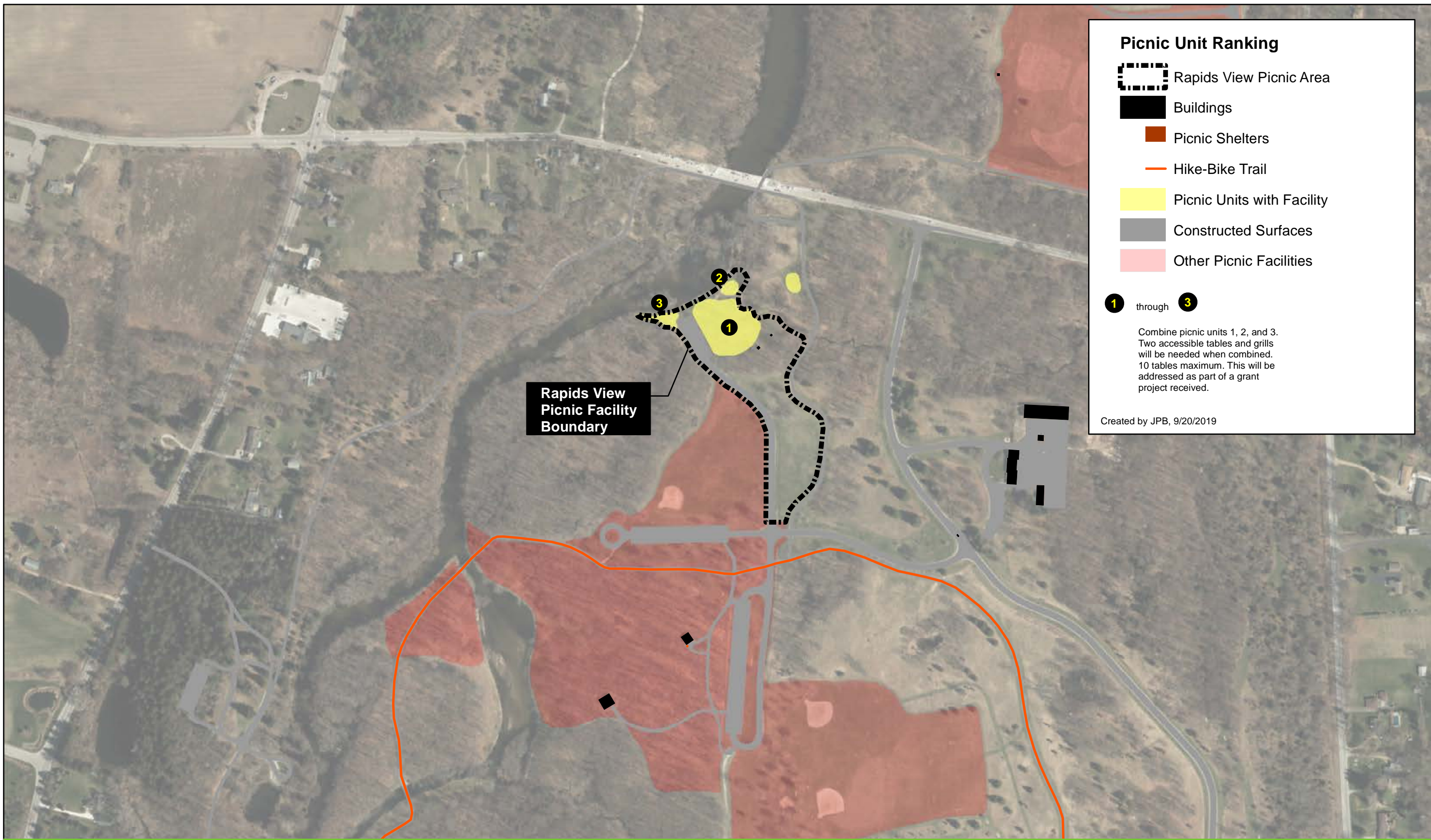

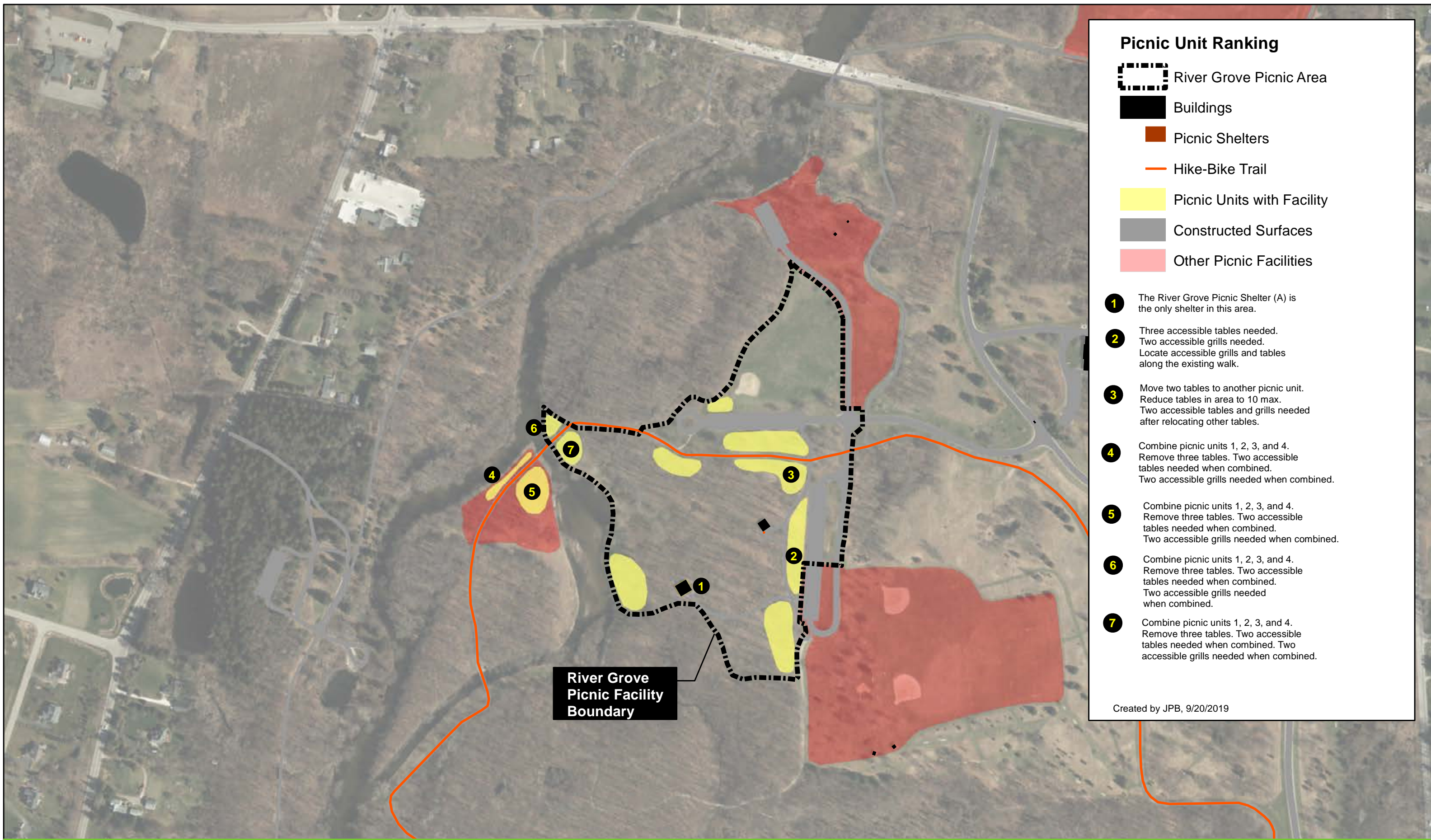

Pine View
Picnic Facility
Boundary



Rapids View Picnic Facility Boundary



Picnic Unit Ranking

-  River Grove Picnic Area
-  Buildings
-  Picnic Shelters
-  Hike-Bike Trail
-  Picnic Units with Facility
-  Constructed Surfaces
-  Other Picnic Facilities

- 1** The River Grove Picnic Shelter (A) is the only shelter in this area.
- 2** Three accessible tables needed. Two accessible grills needed. Locate accessible grills and tables along the existing walk.
- 3** Move two tables to another picnic unit. Reduce tables in area to 10 max. Two accessible tables and grills needed after relocating other tables.
- 4** Combine picnic units 1, 2, 3, and 4. Remove three tables. Two accessible tables needed when combined. Two accessible grills needed when combined.
- 5** Combine picnic units 1, 2, 3, and 4. Remove three tables. Two accessible tables needed when combined. Two accessible grills needed when combined.
- 6** Combine picnic units 1, 2, 3, and 4. Remove three tables. Two accessible tables needed when combined. Two accessible grills needed when combined.
- 7** Combine picnic units 1, 2, 3, and 4. Remove three tables. Two accessible tables needed when combined. Two accessible grills needed when combined.

Created by JPB, 9/20/2019

**River Grove
Picnic Facility
Boundary**

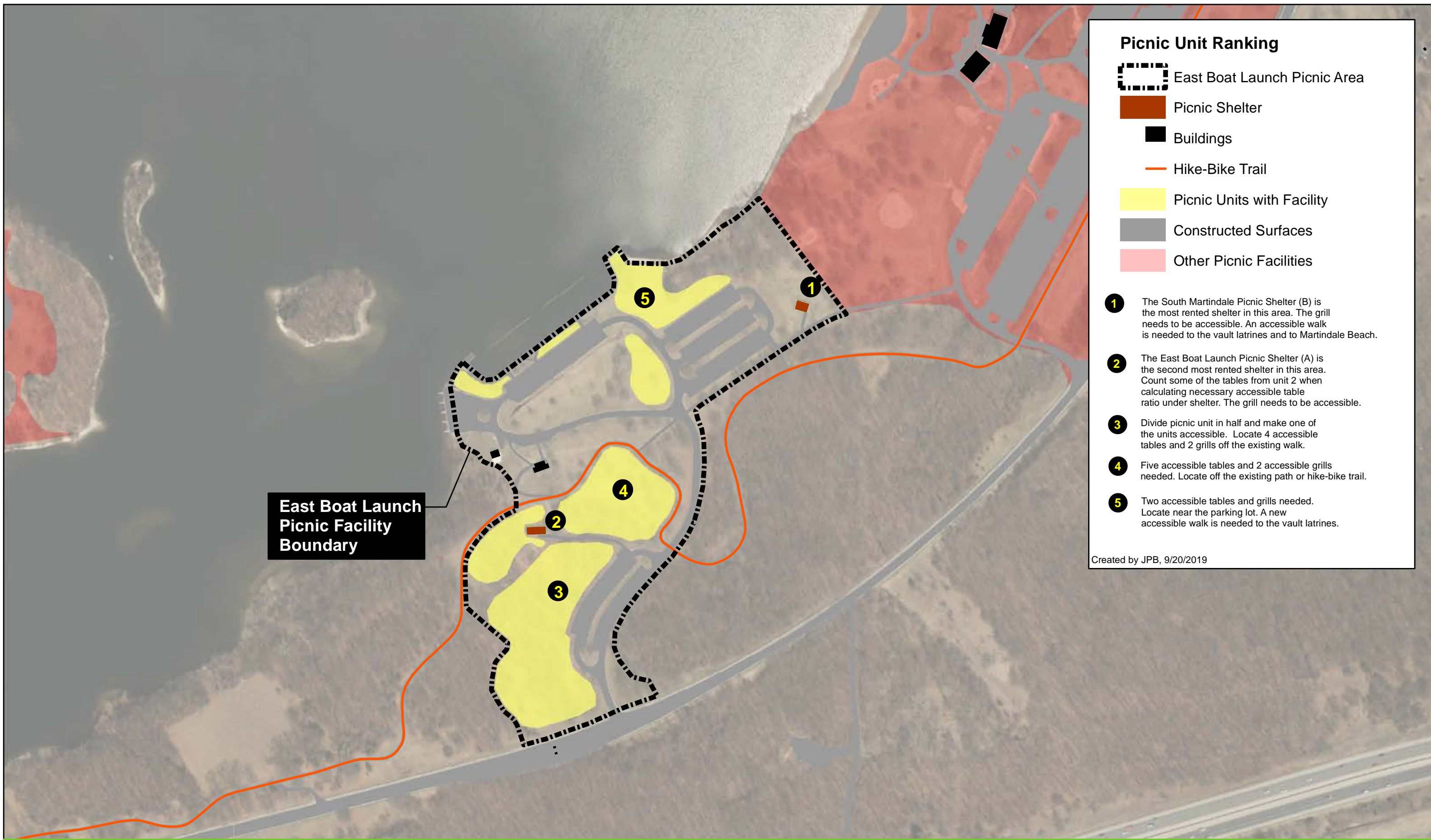

East Boat Launch Picnic Facility Boundary

Picnic Unit Ranking





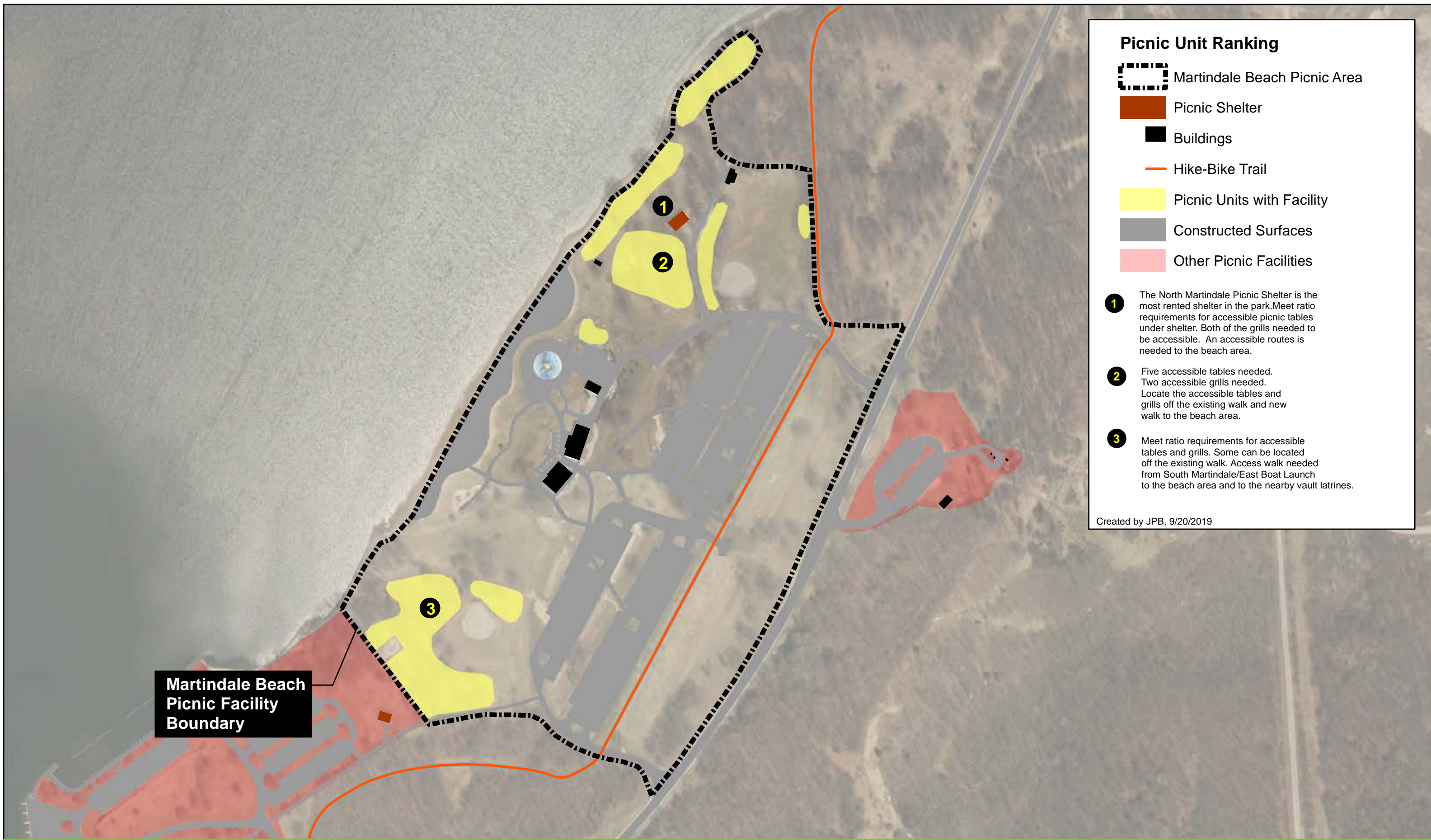

-  East Boat Launch Picnic Area
-  Picnic Shelter
-  Buildings
-  Hike-Bike Trail
-  Picnic Units with Facility
-  Constructed Surfaces
-  Other Picnic Facilities

- 1** The South Martindale Picnic Shelter (B) is the most rented shelter in this area. The grill needs to be accessible. An accessible walk is needed to the vault latrines and to Martindale Beach.
- 2** The East Boat Launch Picnic Shelter (A) is the second most rented shelter in this area. Count some of the tables from unit 2 when calculating necessary accessible table ratio under shelter. The grill needs to be accessible.
- 3** Divide picnic unit in half and make one of the units accessible. Locate 4 accessible tables and 2 grills off the existing walk.
- 4** Five accessible tables and 2 accessible grills needed. Locate off the existing path or hike-bike trail.
- 5** Two accessible tables and grills needed. Locate near the parking lot. A new accessible walk is needed to the vault latrines.

Created by JPB, 9/20/2019



Picnic Unit Ranking

-  Martindale Beach Picnic Area
-  Picnic Shelter
-  Buildings
-  Hike-Bike Trail
-  Picnic Units with Facility
-  Constructed Surfaces
-  Other Picnic Facilities

- 1** The North Martindale Picnic Shelter is the most rented shelter in the park. Meet ratio requirements for accessible picnic tables under shelter. Both of the grills needed to be accessible. An accessible routes is needed to the beach area.
- 2** Five accessible tables needed. Two accessible grills needed. Locate the accessible tables and grills off the existing walk and new walk to the beach area.
- 3** Meet ratio requirements for accessible tables and grills. Some can be located off the existing walk. Access walk needed from South Martindale/East Boat Launch to the beach area and to the nearby vault latrines.

Created by JPB, 9/20/2019

**Martindale Beach
Picnic Facility
Boundary**

Picnic Unit Ranking

 Spring Hill Picnic Facility

 Picnic Shelter

 Buildings

 Hike-Bike Trail

 Picnic Units with Facility

 Constructed Surfaces

 Other Picnic Facilities

- 1** The Spring Hill Picnic Shelter (K) is the only rental shelter in this area. Count all tables surrounding the shelter when calculating table ratio requirements under shelter. Two of the grills need to be accessible.
- 2** Two accessible tables needed. One accessible grill needed. Locate the accessible tables and grill off existing walks.
- 3** Two accessible tables needed. One accessible grill needed. Locate the accessible tables and grill off a new walk to the restroom building.





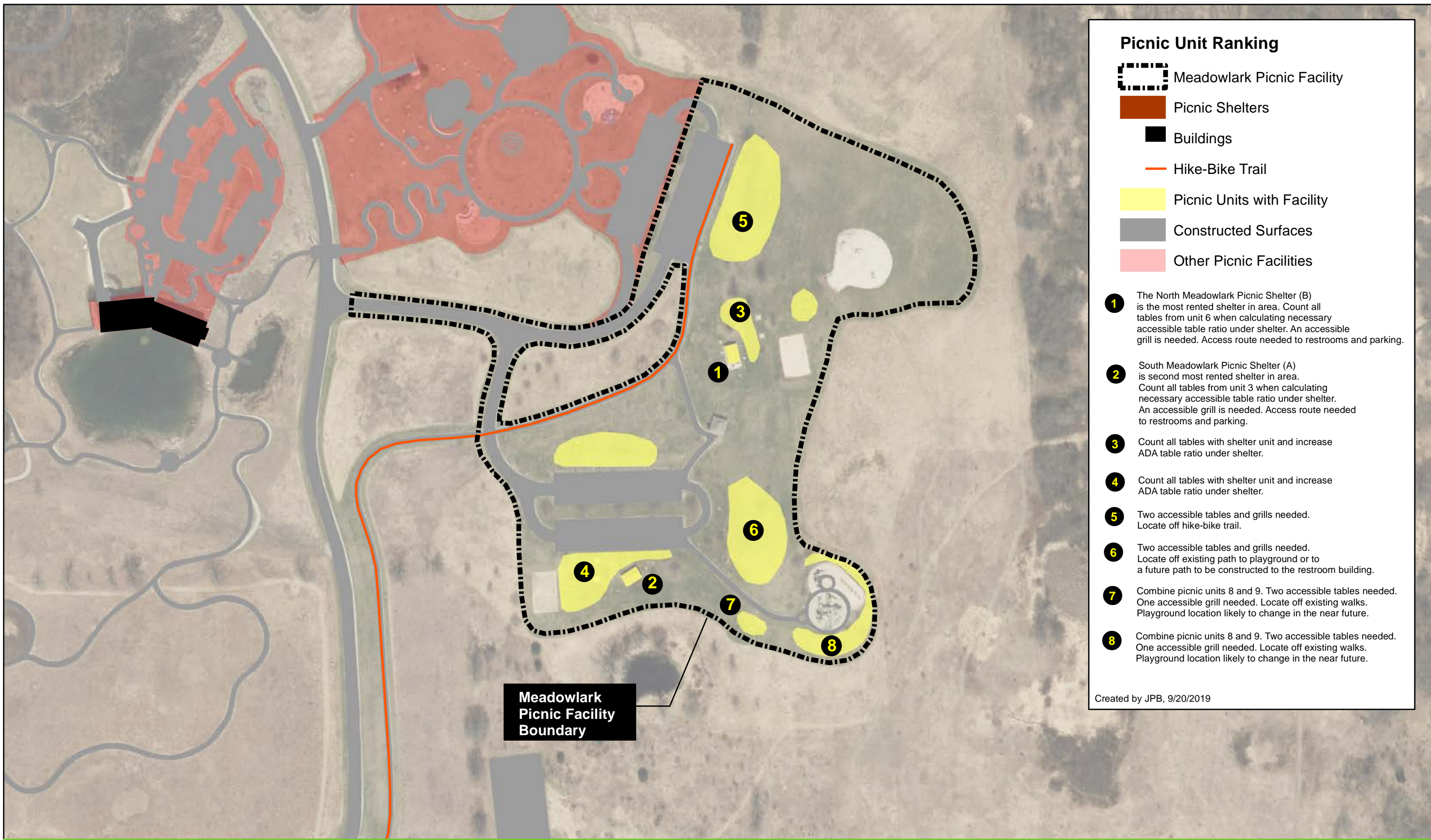

Created by JPB, 9/20/2019

Spring Hill
Picnic Facility
Boundary





Picnic Unit Ranking







-  Meadowlark Picnic Facility
-  Picnic Shelters
-  Buildings
-  Hike-Bike Trail
-  Picnic Units with Facility
-  Constructed Surfaces
-  Other Picnic Facilities

- 1** The North Meadowlark Picnic Shelter (B) is the most rented shelter in area. Count all tables from unit 6 when calculating necessary accessible table ratio under shelter. An accessible grill is needed. Access route needed to restrooms and parking.
- 2** South Meadowlark Picnic Shelter (A) is second most rented shelter in area. Count all tables from unit 3 when calculating necessary accessible table ratio under shelter. An accessible grill is needed. Access route needed to restrooms and parking.
- 3** Count all tables with shelter unit and increase ADA table ratio under shelter.
- 4** Count all tables with shelter unit and increase ADA table ratio under shelter.
- 5** Two accessible tables and grills needed. Locate off hike-bike trail.
- 6** Two accessible tables and grills needed. Locate off existing path to playground or to a future path to be constructed to the restroom building.
- 7** Combine picnic units 8 and 9. Two accessible tables needed. One accessible grill needed. Locate off existing walks. Playground location likely to change in the near future.
- 8** Combine picnic units 8 and 9. Two accessible tables needed. One accessible grill needed. Locate off existing walks. Playground location likely to change in the near future.

Created by JPB, 9/20/2019

Meadowlark Picnic Facility Boundary

Picnic Unit Ranking

-  Park Office Picnic Facility
-  Picnic Shelters
-  Buildings
-  Hike-Bike Trail
-  Picnic Units with Facility
-  Constructed Surfaces
-  Other Picnic Facilities

1 This shelter is not a rental shelter. It is the only shelter in the area. Two accessible tables needed. One accessible grill needed.

Created by JPB, 9/20/2019

Park Office
Picnic Facility
Boundary



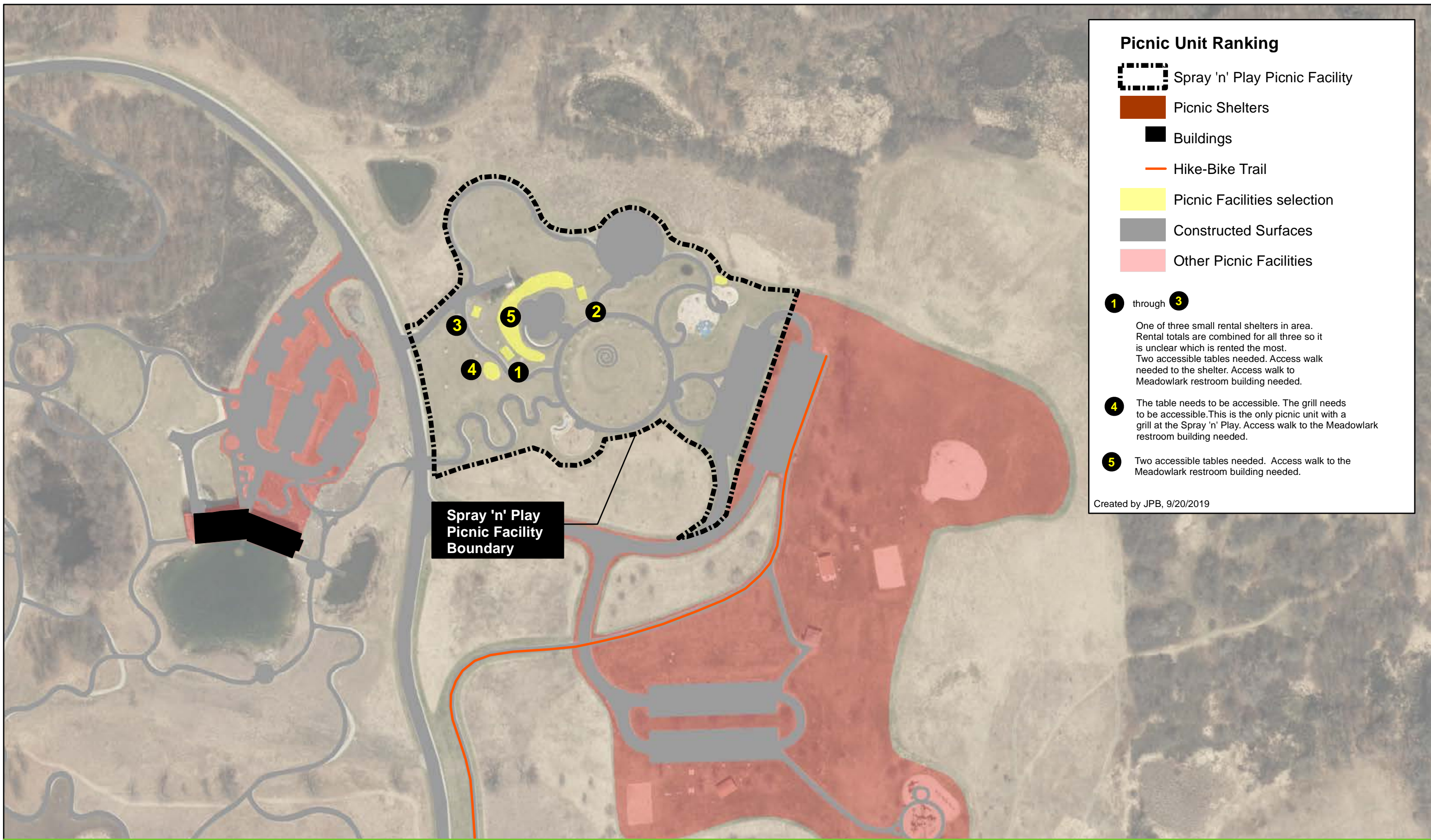

Picnic Unit Ranking

-  Spray 'n' Play Picnic Facility
-  Picnic Shelters
-  Buildings
-  Hike-Bike Trail
-  Picnic Facilities selection
-  Constructed Surfaces
-  Other Picnic Facilities

- 1** through **3**
 One of three small rental shelters in area. Rental totals are combined for all three so it is unclear which is rented the most. Two accessible tables needed. Access walk needed to the shelter. Access walk to Meadowlark restroom building needed.
- 4**
 The table needs to be accessible. The grill needs to be accessible. This is the only picnic unit with a grill at the Spray 'n' Play. Access walk to the Meadowlark restroom building needed.
- 5**
 Two accessible tables needed. Access walk to the Meadowlark restroom building needed.

Created by JPB, 9/20/2019

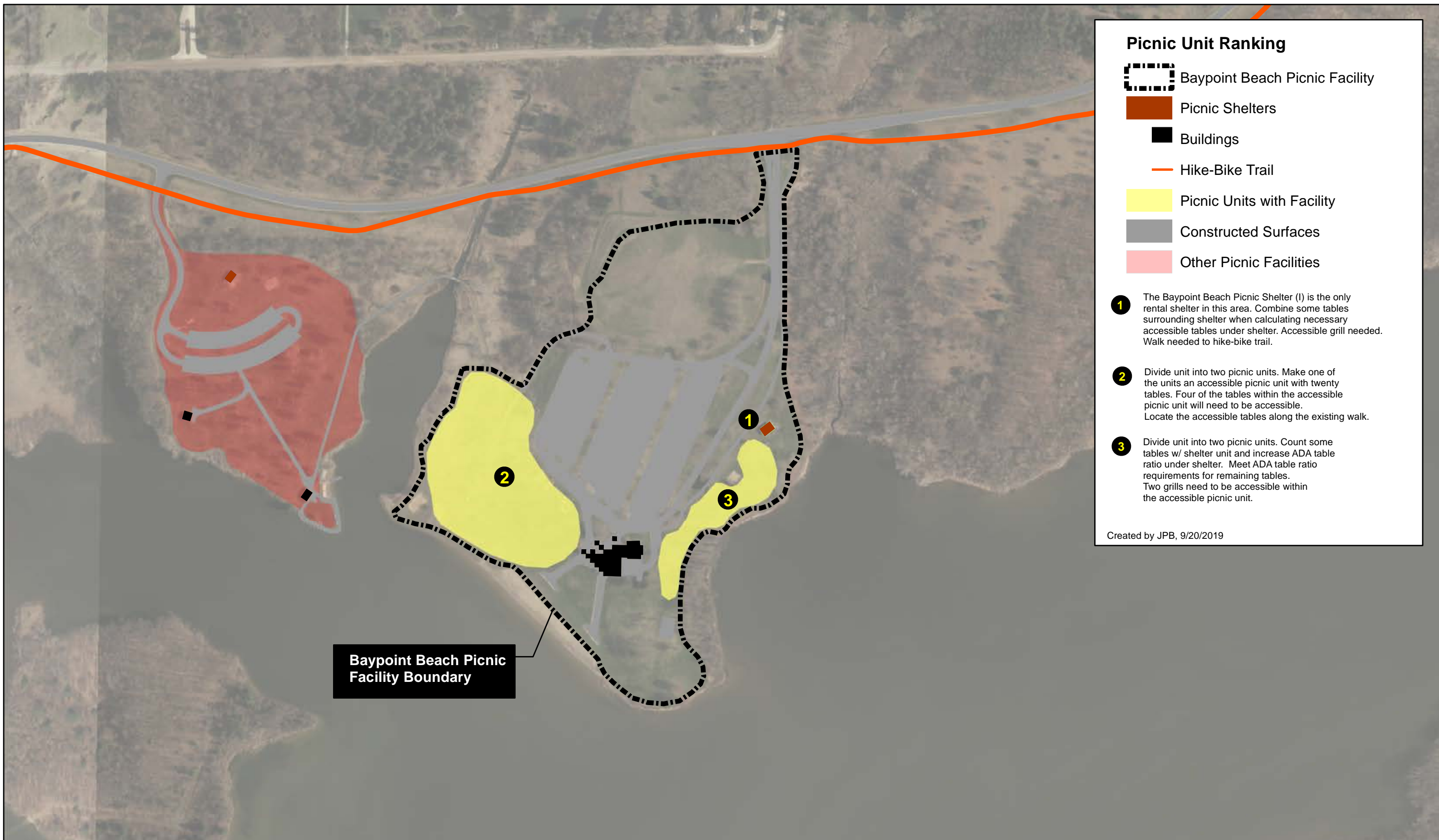

Picnic Unit Ranking

-  Baypoint Beach Picnic Facility
-  Picnic Shelters
-  Buildings
-  Hike-Bike Trail
-  Picnic Units with Facility
-  Constructed Surfaces
-  Other Picnic Facilities

- 1** The Baypoint Beach Picnic Shelter (1) is the only rental shelter in this area. Combine some tables surrounding shelter when calculating necessary accessible tables under shelter. Accessible grill needed. Walk needed to hike-bike trail.
- 2** Divide unit into two picnic units. Make one of the units an accessible picnic unit with twenty tables. Four of the tables within the accessible picnic unit will need to be accessible. Locate the accessible tables along the existing walk.
- 3** Divide unit into two picnic units. Count some tables w/ shelter unit and increase ADA table ratio under shelter. Meet ADA table ratio requirements for remaining tables. Two grills need to be accessible within the accessible picnic unit.

Created by JPB, 9/20/2019

Baypoint Beach Picnic Facility Boundary



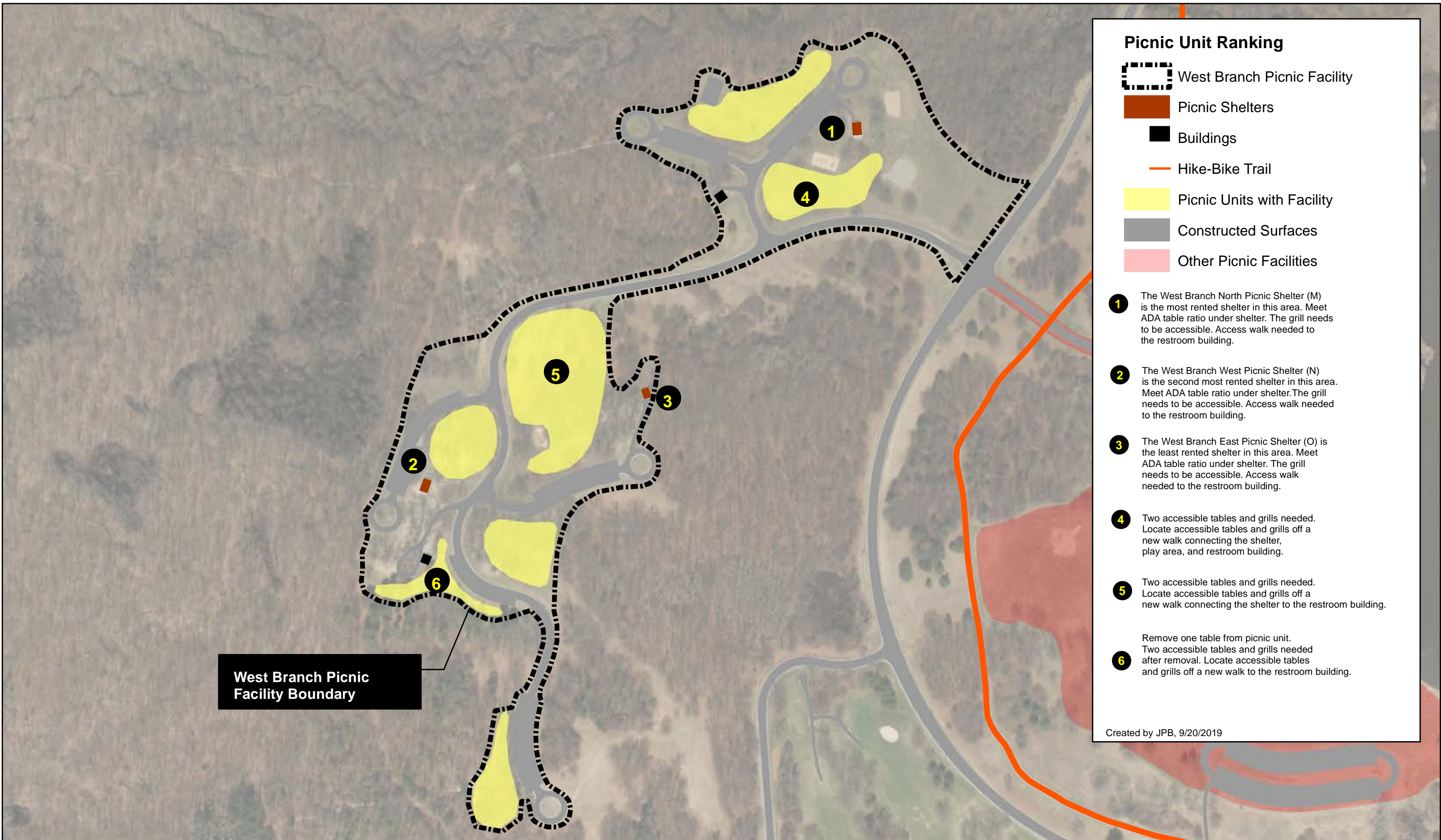

West Branch Picnic Facility Boundary

- ### Picnic Unit Ranking
- West Branch Picnic Facility
 - Picnic Shelters
 - Buildings
 - Hike-Bike Trail
 - Picnic Units with Facility
 - Constructed Surfaces
 - Other Picnic Facilities





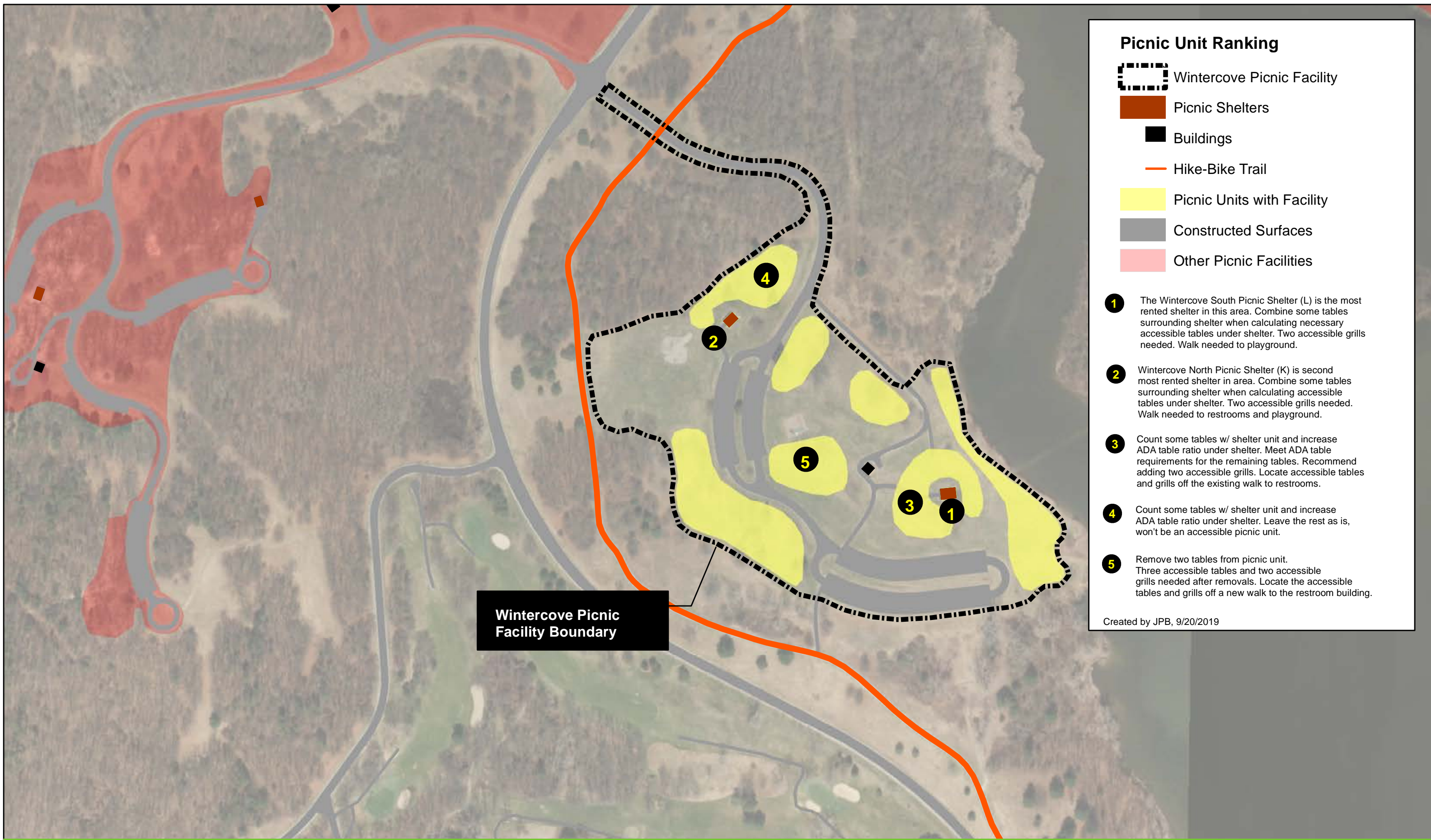

- 1** The West Branch North Picnic Shelter (M) is the most rented shelter in this area. Meet ADA table ratio under shelter. The grill needs to be accessible. Access walk needed to the restroom building.
- 2** The West Branch West Picnic Shelter (N) is the second most rented shelter in this area. Meet ADA table ratio under shelter. The grill needs to be accessible. Access walk needed to the restroom building.
- 3** The West Branch East Picnic Shelter (O) is the least rented shelter in this area. Meet ADA table ratio under shelter. The grill needs to be accessible. Access walk needed to the restroom building.
- 4** Two accessible tables and grills needed. Locate accessible tables and grills off a new walk connecting the shelter, play area, and restroom building.
- 5** Two accessible tables and grills needed. Locate accessible tables and grills off a new walk connecting the shelter to the restroom building.
- 6** Remove one table from picnic unit. Two accessible tables and grills needed after removal. Locate accessible tables and grills off a new walk to the restroom building.

Created by JPB, 9/20/2019



Wintercove Picnic Facility Boundary

Picnic Unit Ranking





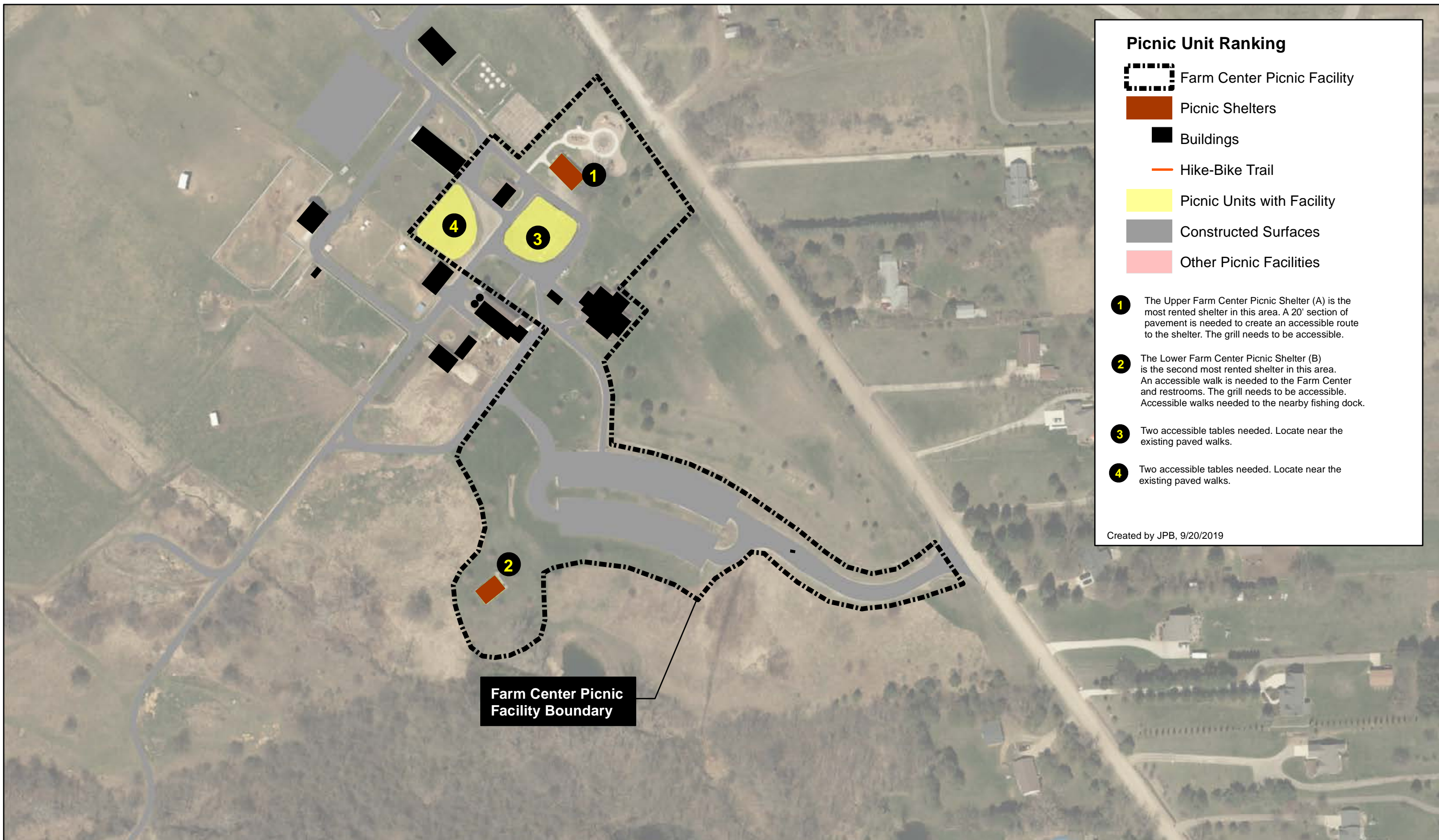

-  Wintercove Picnic Facility
-  Picnic Shelters
-  Buildings
-  Hike-Bike Trail
-  Picnic Units with Facility
-  Constructed Surfaces
-  Other Picnic Facilities

- 1** The Wintercove South Picnic Shelter (L) is the most rented shelter in this area. Combine some tables surrounding shelter when calculating necessary accessible tables under shelter. Two accessible grills needed. Walk needed to playground.
- 2** Wintercove North Picnic Shelter (K) is second most rented shelter in area. Combine some tables surrounding shelter when calculating accessible tables under shelter. Two accessible grills needed. Walk needed to restrooms and playground.
- 3** Count some tables w/ shelter unit and increase ADA table ratio under shelter. Meet ADA table requirements for the remaining tables. Recommend adding two accessible grills. Locate accessible tables and grills off the existing walk to restrooms.
- 4** Count some tables w/ shelter unit and increase ADA table ratio under shelter. Leave the rest as is, won't be an accessible picnic unit.
- 5** Remove two tables from picnic unit. Three accessible tables and two accessible grills needed after removals. Locate the accessible tables and grills off a new walk to the restroom building.

Created by JPB, 9/20/2019



Picnic Unit Ranking





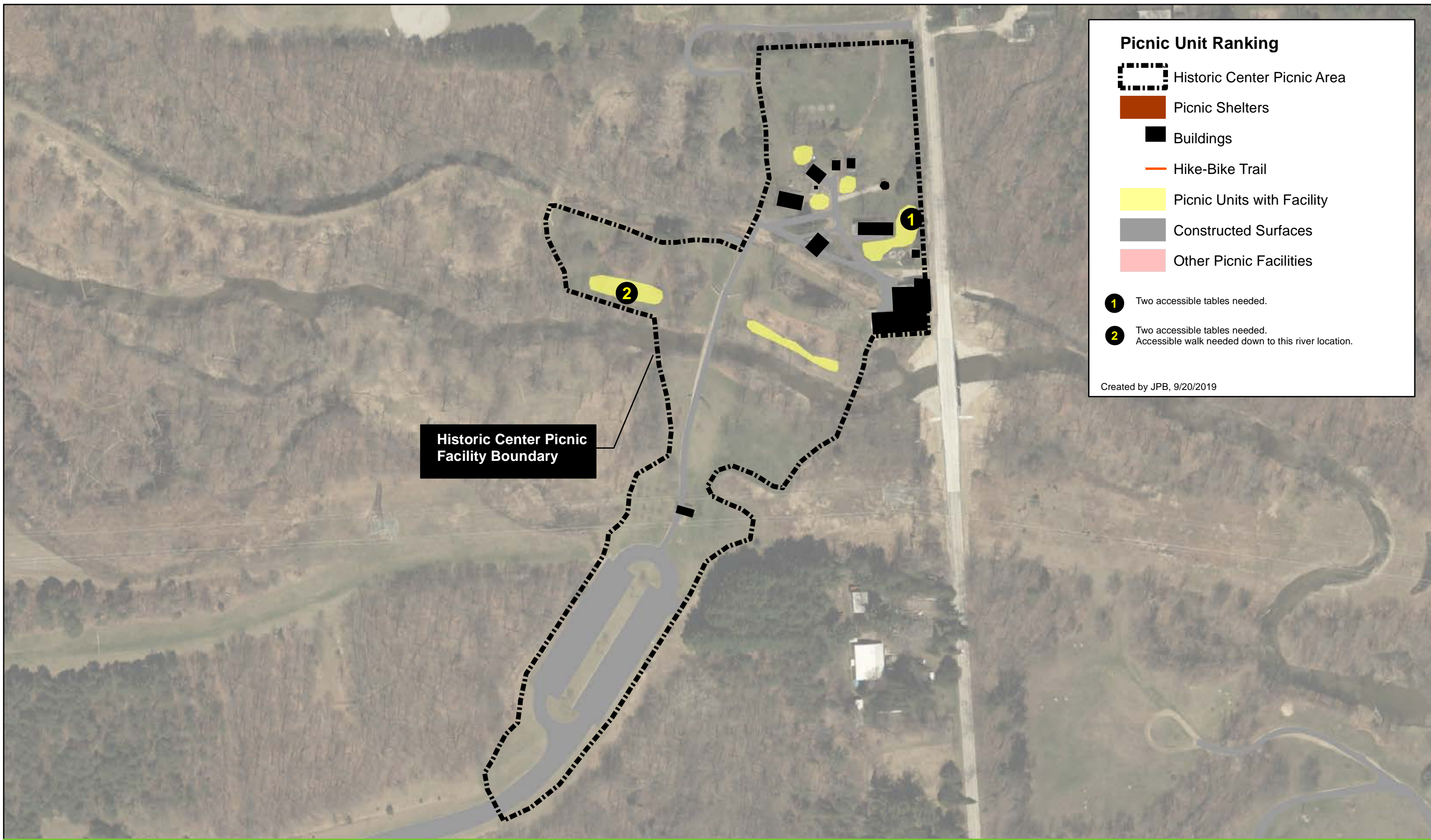

-  Farm Center Picnic Facility
-  Picnic Shelters
-  Buildings
-  Hike-Bike Trail
-  Picnic Units with Facility
-  Constructed Surfaces
-  Other Picnic Facilities

- 1** The Upper Farm Center Picnic Shelter (A) is the most rented shelter in this area. A 20' section of pavement is needed to create an accessible route to the shelter. The grill needs to be accessible.
- 2** The Lower Farm Center Picnic Shelter (B) is the second most rented shelter in this area. An accessible walk is needed to the Farm Center and restrooms. The grill needs to be accessible. Accessible walks needed to the nearby fishing dock.
- 3** Two accessible tables needed. Locate near the existing paved walks.
- 4** Two accessible tables needed. Locate near the existing paved walks.

Created by JPB, 9/20/2019



Picnic Unit Ranking

-  Historic Center Picnic Area
-  Picnic Shelters
-  Buildings
-  Hike-Bike Trail
-  Picnic Units with Facility
-  Constructed Surfaces
-  Other Picnic Facilities

1 Two accessible tables needed.

2 Two accessible tables needed. Accessible walk needed down to this river location.

Created by JPB, 9/20/2019

Historic Center Picnic Facility Boundary

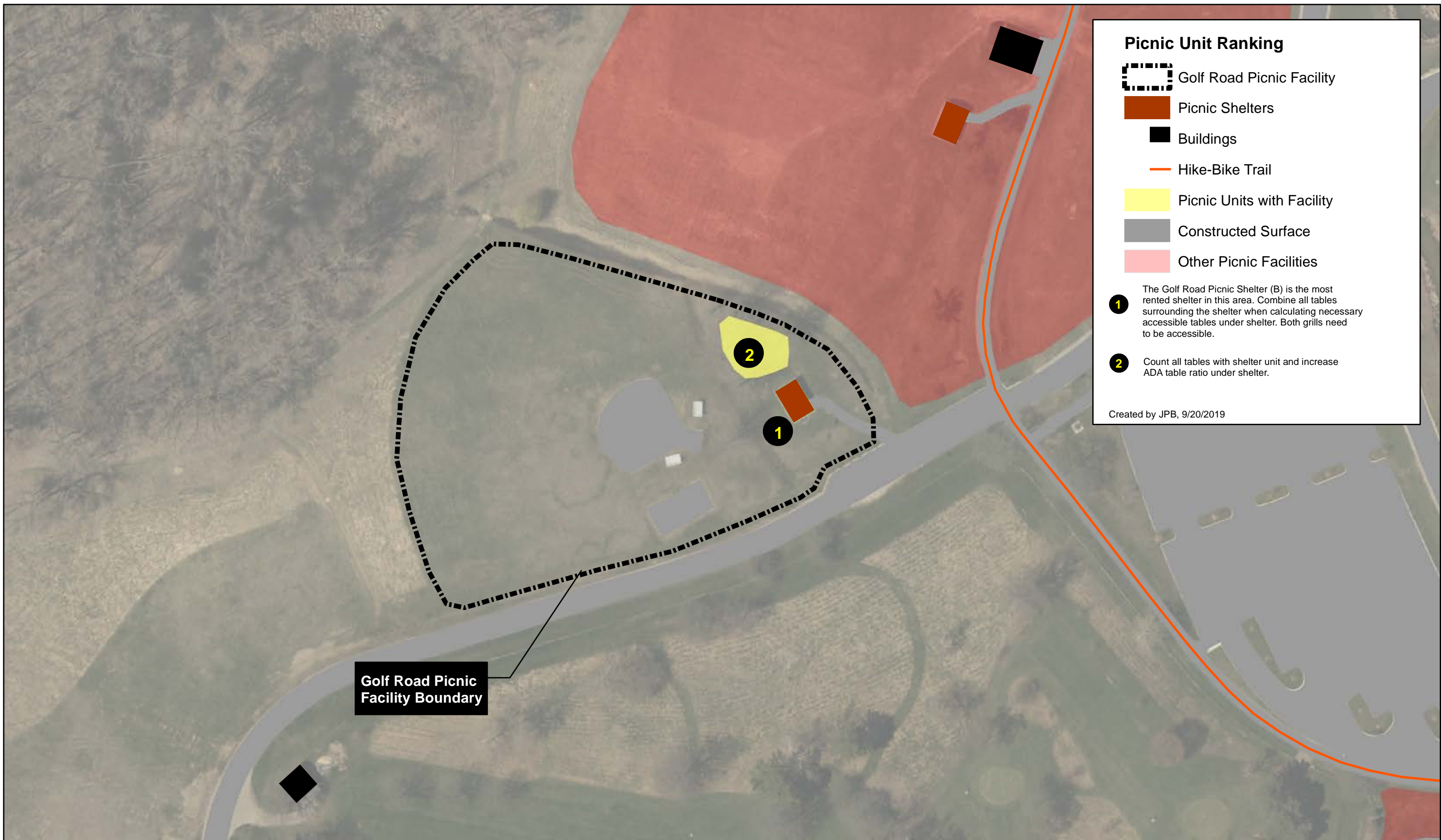

Picnic Unit Ranking

-  Golf Road Picnic Facility
-  Picnic Shelters
-  Buildings
-  Hike-Bike Trail
-  Picnic Units with Facility
-  Constructed Surface
-  Other Picnic Facilities

- 1** The Golf Road Picnic Shelter (B) is the most rented shelter in this area. Combine all tables surrounding the shelter when calculating necessary accessible tables under shelter. Both grills need to be accessible.
- 2** Count all tables with shelter unit and increase ADA table ratio under shelter.

Created by JPB, 9/20/2019

Golf Road Picnic Facility Boundary



Picnic Unit Ranking

-  Par-3 Golf and Group Rental Picnic Area
-  Picnic Shelters
-  Buildings
-  Hike-Bike Trail
-  Picnic Facilities selection
-  Constructed Surface
-  Other Picnic Facilities

1 The Par-3 Picnic Shelter (D) is the only rental shelter in this area. Meet ADA table ratio requirements under shelter. The two existing grills need to be accessible.

Created by JPB, 9/20/2019

Par-3 Golf and Group Rental Shelter
Picnic Facility Boundary



Picnic Unit Ranking

-  Seawall Shelter Picnic Facility
-  Picnic Shelters
-  Buildings
-  Hike-Bike Trail
-  Picnic Units with Facility
-  Constructed Surface
-  Other Picnic Facilities

1 Two accessible tables needed.
 Recommend an accessible grill be added.
 Access walks needed to the parking lot.
 Parking lot renovation is planned and
 will change access to area.

Created by JPB, 9/20/2019

**Seawall Shelter
 Picnic Facility Boundary**



APPENDIX 4: PICNIC FACILITIES PRIORITIZED BY PARK



Picnic Unit Ranking Within Metropark

Metropark	Picnic Facility	Picnic Unit Ranking Within Metropark	Picnic Unit Ranking Within Picnic Facility	Picnic Unit Number Within Facility	Number of Tables	Number of Grills	Recommendations	Meets ADA Currently
Lake Erie	Great Wave	1	2	9	37	3	Blue Heron (B) is the second most rented shelter in this area. Combine all tables counted surrounding shelter when calculating necessary accessible table ratio under shelter. Two accessible grills needed.	No
Lake Erie	Great Wave	2	1	12	12	1	Cattail (C) is the most rented shelter in this area. Combine some tables counted surrounding the shelter when calculating necessary accessible table ratio under shelter. The existing grill needs to be accessible.	No
Lake Erie	Great Wave	3	3	2	12	0	American Lotus (A) is the third most rented shelter in area. Combine some tables counted surrounding shelter when calculating necessary accessible tables. Existing grill needs to be accessible. Accessible walk needed to restrooms / activity area.	No
Lake Erie	Cove Point	4	2	4	15	1	Wood Duck (D) is the second most rented shelter in area. Combine some tables counted surrounding shelter when calculating necessary accessible table ratio under shelter. The existing grill is located along a walkways. Grill needs to be accessible.	No
Lake Erie	Cove Point	5	1	8	12	1	Muskrat (E) is the most rented picnic shelter in this area. Combine tables counted surrounding the shelter when calculating necessary accessible table ratio under shelter. The existing grill needs to be accessible.	No
Lake Erie	Great Wave	6	3	1	9	1	Count some of the tables with the shelter unit and increase the accessible table ratio under shelter. The existing grill needs to be accessible.	No
Lake Erie	Great Wave	7	4	8	9	0	Count all of the tables with the shelter unit and increase the accessible table ratio under shelter.	No
Lake Erie	Cove Point	8	3	3	6	0	Count some tables w/ shelter unit and increase ADA table ratio at shelter. Meet ratio requirements for ADA tables / grills. Add necessary access routes or locate along existing accessible routes. Two free picnic units recommended at each lot.	No
Lake Erie	Great Wave	9	4	14	99	19	Divide this large unit into two and make one of them accessible. Meet accessible table and grill ratio requirements. Locate the accessible tables and grill near the existing walk.	No
Lake Erie	Great Wave	10	5	10	16	4	Meet ratio requirements for accessible tables and grills. Add accessible walks as needed and connect to Great Wave walkways for restroom, pool, playground, and food bar access.	No
Lake Erie	Cove Point	11	4	5	7	2	Two accessible tables needed. Both grills need to be accessible. Locate accessible tables and grills along the existing walkways.	No

Lake Erie	Cove Point	12	5	24	17	4	Meet ratio requirements for accessible tables and grills. Add necessary accessible routes or locate along existing hike-bike trail.	No
Lake Erie	Cove Point	13	6	12	18	3	Divide this large area into two picnic units. Make one of them an accessible picnic unit. Meet ratio requirements for accessible tables and grills. Add necessary accessible routes as needed.	No
Lake Erie	Cove Point	14	7	25	8	2	Meet ratio requirements for accessible tables and grills. Add necessary accessible routes. Two free picnic areas recommended at each lot.	No
Lake Erie	Marina Point	15	1	2	6	0	Two of the tables are accessible. No work needed.	No
Lake Erie	Marina Point	16	2	3	5	0	Two accessible tables needed. One of the tables is an accessible table but lacks an accessible route to the table. Modify another table and construct access paths as needed.	No
Lake Erie	Shore Fishing	17	1	1	6	1	Two accessible tables needed. The existing grill needs to be accessible.	No
Lake Erie	Cove Point			1	5	1	Leave as is, won't be an accessible picnic unit.	No
Lake Erie	Marina Point			1	3	0	Leave as is, won't be an accessible picnic unit.	No
Lake Erie	Cove Point			2	9	2	Leave as is, won't be an accessible picnic unit.	No
Lake Erie	Great Wave			3	3	1	Leave as is, won't be an accessible picnic unit.	No
Lake Erie	Great Wave			4	8	1	Leave as is, won't be an accessible picnic unit.	No
Lake Erie	Great Wave			5	3	0	Leave as is, won't be an accessible picnic unit.	No
Lake Erie	Cove Point			6	4	1	Leave as is, won't be an accessible picnic unit.	No
Lake Erie	Great Wave			6	6	1	Leave as is, won't be an accessible picnic unit.	No
Lake Erie	Cove Point			7	20	5	Leave as is, won't be an accessible picnic unit.	No
Lake Erie	Great Wave			7	31	0	Leave as is, won't be an accessible picnic unit.	No
Lake Erie	Cove Point			9	6	1	Leave as is, won't be an accessible picnic unit.	No
Lake Erie	Cove Point			10	4	1	Leave as is, won't be an accessible picnic unit.	No
Lake Erie	Cove Point			11	4	1	Leave as is, won't be an accessible picnic unit.	No
Lake Erie	Great Wave			11	3	0	Leave as is, won't be an accessible picnic unit.	No
Lake Erie	Great Wave			13	4	1	Leave as is, won't be an accessible picnic unit.	No
Lake Erie	Cove Point			13	2	0	Leave as is, won't be an accessible picnic unit. Combine many of the water's edge units to reduce picnic unit count under 20.	No
Lake Erie	Cove Point			14	4	1	Leave as is, won't be an accessible picnic unit. Combine many of the water's edge units to reduce picnic unit count under 20.	No
Lake Erie	Cove Point			15	0	1	Leave as is, won't be an accessible picnic unit. Combine many of the water's edge units to reduce picnic unit count under 20.	No
Lake Erie	Cove Point			16	4	1	Leave as is, won't be an accessible picnic unit.	No
Lake Erie	Cove Point			17	4	1	Leave as is, won't be an accessible picnic unit.	No
Lake Erie	Cove Point			18	2	0	Leave as is, won't be an accessible picnic unit. Combine many of the water's edge units to reduce picnic unit count under 20.	No
Lake Erie	Cove Point			19	2	1	Leave as is, won't be an accessible picnic unit. Combine many of the water's edge units to reduce picnic unit count under 20.	No
Lake Erie	Cove Point			20	4	1	Leave as is, won't be an accessible picnic unit.	No
Lake Erie	Cove Point			21	0	1	Leave as is, won't be an accessible picnic unit. Combine many of the water's edge units to reduce picnic unit count under 20.	No

Lake Erie	Cove Point	22	0	1	Leave as is, won't be an accessible picnic unit. Combine many of the water's edge units to reduce picnic unit count under 20.	No
Lake Erie	Cove Point	23	4	1	Leave as is, won't be an accessible picnic unit. Combine many of the water's edge units to reduce picnic unit count under 20.	No
Lake Erie	Cove Point		1	0	Not a picnic unit. Count table with the shelter unit and increase the accessible table ratio under shelter.	No
Lake Erie	Great Wave		11	0	Not a picnic unit. Food Bar patio will be evaluated separately.	No
Lake Erie	Great Wave		14	0	Not a picnic unit. Food Bar will be evaluated separately. Moveable furniture inside appears to be accessible.	No
Lake Erie	Golf Course		3	0	Not a picnic unit. Golf Course will be evaluated separately. Tables don't match. There are matching tables at maintenance yard that need repair. Two accessible tables needed.	No
Lake Erie	Marina		2	0	Not a picnic unit. Marina facilities will be evaluated separately.	No
Lake Erie	Marina		5	1	Not a picnic unit. Marina facilities will be evaluated separately.	No
Lake Erie	Marina		4	0	Not a picnic unit. Marina facilities will be evaluated separately.	No
Lake Erie	Marina		1	0	Not a picnic unit. Marina facilities will be evaluated separately.	No
Lake Erie	Marina		1	0	Not a picnic unit. Marina facilities will be evaluated separately.	No
Lake Erie	Marina		1	0	Not a picnic unit. Marina facilities will be evaluated separately.	No
Lake Erie	Marina		1	0	Not a picnic unit. Marina facilities will be evaluated separately.	No
Lake Erie	Marina		29	0	Not a picnic unit. Marina facilities will be evaluated separately. Meet ratio requirements for accessible tables. Locate off existing walkway.	No
Lake Erie	Marina Overflow Lot		1	0	Not a picnic unit. Marina facilities will be evaluated separately. Relocate table closer to Marina Building / restrooms	No
Lake Erie	Marina Overflow Lot		4	0	Not a picnic unit. Marina facilities will be evaluated separately. Relocate tables closer to Marina Building / restrooms	No
Lake Erie	Cove Point		1	0	Not a picnic unit. Move table to a picnic unit.	No
Lake Erie	Marina Point		1	0	Not a picnic unit. Move table to a picnic unit.	No
Lake Erie	Marshlands Museum		1	0	Not a picnic unit. Patio area at the Marshlands Museum will be evaluated separately. An accessible table is needed.	No
Lake Erie	Cove Point		1	0	Not a picnic unit. Relocate table to a picnic unit.	No
Lake Erie	Great Wave		1	0	Not a picnic unit. Relocate table to a picnic unit.	No
Lake Erie	Great Wave		1	0	Not a picnic unit. Relocate table to a picnic unit.	No
Lake Erie	Boat, Canoe, & Kayak Launch		1	0	Not a picnic unit. Relocate table to a picnic unit. Benches only.	No

Lake Erie	Boat, Canoe, & Kayak Launch	1	0	Not a picnic unit. Remove table from island area and move to another picnic unit.	No
Lake Erie	Service Yard	2	0	Not a picnic unit. Tables match those at the Golf Course. Repair tables and move back to Golf Course.	No
Lake Erie	Boat, Canoe, & Kayak Launch	1	0	Not a picnic unit. The Boat Launch will be reviewed separately. A grant application has been submitted to make this area accessible. Two accessible tables and grills to be added.	No
Lake Erie	Boat, Canoe, & Kayak Launch	2	0	Not a picnic unit. The Boat Launch will be reviewed separately. Leave as is, won't be an accessible picnic unit.	No
Lake Erie	Boat, Canoe, & Kayak Launch	11	2	Not a picnic unit. The Boat Launch will be reviewed separately. Move one table to another picnic unit, 10 tables, max. Two accessible tables needed. Two accessible grills needed.	No
Lake Erie	Marshlands Museum	3	0	Not a picnic unit. The Marshlands Museum will be evaluated separately. Two of the existing tables need to be accessible and located in accessible locations.	No

Picnic Unit Ranking Within Metropark

Metropark	Picnic Facility	Picnic Unit Ranking Within Metropark	Picnic Unit Ranking Within Picnic Facility	Picnic Unit Number Within Facility	Number of Tables	Number of Grills	Recommendations	Meets ADA Currently
Oakwoods	Nature Center	1	1	1	7	1	Two accessible tables needed. The grill needs to be accessible. Walks needed to the accessible tables and grill. An accessible route is also needed to the Oakwoods Nature Center restrooms.	No
Oakwoods	Cedar Knoll	2	1	4	3	1	Two accessible tables needed. Locate accessible tables along a new accessible route from the parking lot the vault latrines. The existing grill needs to be accessible.	No
Oakwoods	Cedar Knoll	3	2	5	2	0	Two accessible tables needed. Locate accessible tables along a new accessible route from the parking lot the vault latrines. Add an accessible grill so that there are two within the Cedar Knoll picnic facility.	No
Oakwoods	Equestrian Staging	4	1	1	4	1	Two accessible tables needed. The grill needs to be accessible. Accessible routes needed to the proposed accessible tables and grill and to the port-a-john across the road.	No
Oakwoods	Cedar Knoll			1	1	1	Leave as is, won't be an accessible picnic unit.	No
Oakwoods	Cedar Knoll			2	0	1	Leave as is, won't be an accessible picnic unit.	No
Oakwoods	Cedar Knoll			3	5	1	Leave as is, won't be an accessible picnic unit.	No
Oakwoods	Cedar Knoll			6	1	1	Remove picnic unit when parking lot is removed.	No
Oakwoods	Cedar Knoll			7	4	1	Remove picnic unit when parking lot is removed.	No
Oakwoods	Cedar Knoll			8	4	1	Remove picnic unit when parking lot is removed.	No
Oakwoods	Nature Center				2	0	Not a picnic unit. Both tables will be made accessible as part of a proposed grant project.	No
Oakwoods	Cedar Knoll				1	0	Not a picnic unit. This is the Motor City Canoe and Kayak Staging Area which will be evaluated separately.	No

Picnic Unit Ranking Within Metropark

Metropark	Picnic Facility	Picnic Unit Ranking Within Metropark	Picnic Unit Ranking Within Picnic Facility	Picnic Unit Number Within Facility	Number of Tables	Number of Grills	Recommendations	Meets ADA Currently
Willow	Washago Pond	1	1	6	15	2	The Washago Pond Picnic Shelter (A) is the only rental shelter in the area. Count some tables surrounding shelter when calculating necessary accessible table ratio under shelter. Both grills need to be accessible.	No
Willow	Fox Meadows	2	2	6	16	2	Fox Meadows South Shelter (F) is the most rented shelter in area. Both grills need to be accessible. Both grills are located on pavement off a walkway. Access walk needed to Pool Activity Area.	No
Willow	Flint Woods	3	1	6	20	3	Flint Woods Picnic Shelter (C) is the only rental shelter in area. Combine some tables counted surrounding shelter when calculating necessary accessible table ratio under shelter. One of the grills is accessible. Two grills need to be accessible.	No
Willow	Pool Activity Center	4	1	2	15	2	The Pool Picnic Shelter (B) is the only rental shelter in the area. Count all tables surrounding shelter when calculating necessary accessible table ratio under shelter. Both grills need to be accessible. Access walk needed to pool area.	No
Willow	Fox Meadows	5	1	2	15	2	Fox Meadows North Picnic Shelter (G) is second most rented shelter in area. Count tables surrounding shelter when calculating necessary accessible table ratio under shelter. Two accessible grills needed. Walk needed to closest restroom building.	No
Willow	Chestnut	6	1	11	11	3	The Chestnut North Picnic Shelter (D) is the second most rented shelter in this area. Count all tables surrounding shelter when calculating necessary accessible table ratio under shelter. Two of the three grills need to be accessible.	No
Willow	Big Bend	7	1	9	11	1	The Big Bend Picnic Shelter (H) is the only rental shelter in area. Count all tables surrounding shelter when calculating necessary accessible table ratio under shelter. The grill needs to be accessible. Access walk needed to restroom building.	No
Willow	Chestnut	8	2	12	10	1	The Chestnut South Picnic Shelter (E) is the second most rented shelter in area. Count some tables surrounding shelter when calculating necessary accessible table ratio under shelter. Accessible grill needed. Access walk needed to restrooms.	No
Willow	Washago Pond	9	2	4	32	1	Count some tables w/ shelter unit and increase ADA table ratio under shelter. Meet ratio requirements for ADA tables. The existing grill needs to be accessible.	No
Willow	Fox Meadows	10	4	1	8	0	Count all of the tables as part of the shelter unit and increase accessible table ratio under shelter. An access walk is needed to the closest restroom building. Recommend extending the access walk to hike-bike trail.	No

Willow	Chestnut	11	3	5	7	0	Count some of the tables as part of the shelter unit and increase accessible table ratio under shelter.	No
Willow	Chestnut	12	4	10	6	0	Count all tables as part of the shelter unit and increase accessible table ratio under shelter.	No
Willow	Chestnut	13	5	6	14	2	Count some of the tables as part of the shelter unit and increase accessible table ratio under shelter. Locate 2 accessible tables and grills near the river with a new walk to them.	No
Willow	Big Bend	14	2	8	12	0	Count all tables as part of the shelter unit and increase accessible table ratio under shelter. Access walk needed to the closest restroom building. There has been discussion about removing the shelter and parking lot in the future.	No
Willow	Pool Activity Center	15	2	1	3	1	Two accessible tables needed. The grill needs to be accessible. A new walk is needed connecting the accessible table and grill to the Activity Center area.	No
Willow	Pool Activity Center	16	3	3	4	0	Two accessible tables needed. Staff has started work on the development plan but it had not been completed at the time of this survey. Several accessible units to be constructed.	No
Willow	Washago Pond	17	3	5	7	1	Two accessible tables needed. One accessible grill needed. Locate the accessible tables and grill off the existing paths.	No
Willow	Washago Pond	18	4	1	3	1	Relocate this picnic unit east of the parking lot to improve access to the restrooms and trail. Locate off an existing walk.	No
Willow	Elder Creek	19	1	4	30	2	Six accessible tables needed. Both grills need to be accessible. Locate accessible tables and grills off the existing walk to the restroom building and off of additional walkways as needed.	No
Willow	Indian Ridge	20	1	1	1	1	Combine all picnic units. Remove one table, ten tables max when combined. Two accessible tables and grills needed when combined. Lot reconfiguration proposed. Locate accessible tables and grills off existing and proposed walks.	No
Willow	Indian Ridge	21	2	3	3	2	Combine all picnic units. Remove one table, ten tables max when combined. Two accessible tables and grills needed when combined. Lot reconfiguration proposed. Locate accessible tables and grills off existing and proposed walks.	No
Willow	Indian Ridge	22	3	6	2	1	Combine all picnic units. Remove one table, ten tables max when combined. Two accessible tables and grills needed when combined. Lot reconfiguration proposed. Locate accessible tables and grills off existing and proposed walks.	No
Willow	Indian Ridge	23	4	2	2	1	Combine all picnic units. Remove one table, ten tables max when combined. Two accessible tables and grills needed when combined. Lot reconfiguration proposed. Locate accessible tables and grills off existing and proposed walks.	No
Willow	Indian Ridge	24	5	4	2	1	Combine all picnic units. Remove one table, ten tables max when combined. Two accessible tables and grills needed when combined. Lot reconfiguration proposed. Locate accessible tables and grills off existing and proposed walks.	No

Willow	Indian Ridge	25	6	5	1	1	Combine all picnic units. Remove one table, ten tables max when combined. Two accessible tables and grills needed when combined. Lot reconfiguration proposed. Locate accessible tables and grills off existing and proposed walks.	No
Willow	Flint Woods	26	2	10	36	2	Meet ratio requirements for tables and grills. Some of the accessible tables and grills can be located off the existing walk. Addition walk spurs will be needed for this large number of tables.	No
Willow	Acorn Knoll	27	1	3	2	0	Combine picnic units 1 and 2. Add two accessible tables. Recommend adding 2 accessible grills. Locate the accessible tables and grills off a new walk connecting the parking lot, vault latrines, and play area. Provide access to hike-bike trail.	No
Willow	Acorn Knoll	28	2	4	2	0	Combine picnic units 1 and 2. Add two accessible tables. Recommend adding 2 accessible grills. Locate the accessible tables and grills off a new walk connecting the parking lot, vault latrines, and play area. Provide access to hike-bike trail.	No
Willow	Elder Creek	29	2	3	3	1	Combine picnic units 2 and 3. Limit tables to 10 max. Two accessible tables needed. Add a second grill and make both accessible. Locate the accessible tables and grills off the walk to the restroom building.	No
Willow	Elder Creek	30	3	2	10	0	Combine picnic units 2 and 3. Limit tables to 10 max. Two accessible tables needed. Add a second grill and make both accessible. Locate the accessible tables and grills off the walk to the restroom building.	No
Willow	Flint Woods	31	3	9	10	1	Two accessible tables needed. The grill needs to be accessible.	No
Willow	Fox Meadows	32	3	4	4	1	Two accessible tables needed. The grill needs to be accessible. Locate the accessible tables and grill off the access walk to the Pool Activity Area.	No
Willow	Washago Pond	33	5	11	1	1	The table and grill need to be accessible. An accessible walk is needed connecting the parking lot to the hike-bike trail. Locate the table and grill off one of these walks so there is access to restrooms from the trail.	No
Willow	Big Bend	34	3	7	5	1	Combine picnic units 6 and 7. Ten tables max. Two accessible tables and grills needed. Locate off the existing path and hike-bike trail.	No
Willow	Big Bend	35	4	6	4	1	Combine picnic units 6 and 7. Ten tables max. Two accessible tables and grills needed. Locate off the existing path and hike-bike trail.	No
Willow	Flint Woods	36	4	12	3	1	Two accessible tables needed. The grill needs to be accessible. Locate off the existing walk to the restroom building.	No
Willow	Acorn Knoll	37	3	5	3	2	Two accessible tables and grills needed. Locate accessible tables and grills of the existing connector path. Access walk needed to the vault latrines.	No
Willow	Fox Meadows	38	5	3	4	2	Two accessible tables and grills needed. Locate the accessible tables and grills off the access walk to the Pool Activity Area.	No

Willow	Big Bend	39	5	13	3	1	Two accessible tables needed. The grill needs to be accessible.	No
Willow	Chestnut	40	6	2	11	0	Remove one table, ten tables max. Two accessible tables will be needed after removal. Add two accessible grills. Locate accessible tables and grills off the existing walk.	No
Willow	Chestnut	41	7	7	5	3	Combine picnic units 7 and 8. Two accessible tables and grills needed. Access walk needed to restroom building. Locate accessible tables and grills off the proposed walk from the nearby shelter to the restroom building.	No
Willow	Chestnut	42	8	8	2	1	Combine picnic units 7 and 8. Two accessible tables and grills needed. Access walk needed to restroom building. Locate accessible tables and grills off the proposed walk from the nearby shelter to the restroom building.	No
Willow	Big Bend	43	7	2	4	1	Combine picnic units 1 and 2. Two accessible tables and one accessible grill needed when combined. Locate the accessible tables and grill off a new walk connecting the parking lot to the hike-bike trail.	No
Willow	Big Bend	44	8	1	1	0	Combine picnic units 1 and 2. Two accessible tables and one accessible grill needed when combined. Locate the accessible tables and grill off a new walk connecting the parking lot to the hike-bike trail.	No
Willow	Big Bend	45	6	14	2	2	Two accessible tables and grills needed. Access walk needed connecting this area to the parking lot, restroom building, and hike-bike trail.	No
Willow	Big Bend	46	9	11	3	1	Two accessible tables needed. The grill needs to be accessible.	No
Willow	Acorn Knoll			1	1	1	Leave as is, won't be an accessible picnic unit.	No
Willow	Chestnut			1	5	1	Leave as is, won't be an accessible picnic unit.	No
Willow	Elder Creek			1	6	2	Leave as is, won't be an accessible picnic unit.	No
Willow	Flint Woods			1	4	1	Leave as is, won't be an accessible picnic unit.	No
Willow	Acorn Knoll			2	3	1	Leave as is, won't be an accessible picnic unit.	No
Willow	Flint Woods			2	2	1	Leave as is, won't be an accessible picnic unit.	No
Willow	Washago Pond			2	2	0	Leave as is, won't be an accessible picnic unit.	No
Willow	Big Bend			3	1	1	Leave as is, won't be an accessible picnic unit.	No
Willow	Chestnut			3	9	1	Leave as is, won't be an accessible picnic unit.	No
Willow	Flint Woods			3	6	1	Leave as is, won't be an accessible picnic unit.	No
Willow	Washago Pond			3	2	0	Leave as is, won't be an accessible picnic unit.	No
Willow	Big Bend			4	2	0	Leave as is, won't be an accessible picnic unit.	No
Willow	Chestnut			4	10	1	Leave as is, won't be an accessible picnic unit.	No
Willow	Flint Woods			4	6	1	Leave as is, won't be an accessible picnic unit.	No
Willow	Pool Activity Center			4	3	0	Leave as is, won't be an accessible picnic unit. Tables are located on pavement but not accessible.	No
Willow	Fox Meadows			5	2	0	Count both tables as part of the shelter unit and increase accessible table ratio under shelter.	No
Willow	Big Bend			5	1	1	Leave as is, won't be an accessible picnic unit.	No
Willow	Elder Creek			5	4	1	Leave as is, won't be an accessible picnic unit.	No
Willow	Flint Woods			5	42	0	Leave as is, won't be an accessible picnic unit.	No

Willow	Acorn Knoll	6	3	3	Leave as is, won't be an accessible picnic unit.	No
Willow	Elder Creek	6	3	2	Leave as is, won't be an accessible picnic unit.	No
Willow	Acorn Knoll	7	3	1	Leave as is, won't be an accessible picnic unit.	No
Willow	Flint Woods	7	19	3	Leave as is, won't be an accessible picnic unit.	No
Willow	Washago Pond	7	8	0	Leave as is, won't be an accessible picnic unit.	No
Willow	Flint Woods	8	6	4	Leave as is, won't be an accessible picnic unit.	No
Willow	Washago Pond	8	3	0	Leave as is, won't be an accessible picnic unit.	No
Willow	Chestnut	9	3	1	Leave as is, won't be an accessible picnic unit.	No
Willow	Washago Pond	9	2	1	Leave as is, won't be an accessible picnic unit.	No
Willow	Big Bend	10	3	1	Leave as is, won't be an accessible picnic unit.	No
Willow	Washago Pond	10	5	0	Leave as is, won't be an accessible picnic unit.	No
Willow	Flint Woods	11	4	1	Leave as is, won't be an accessible picnic unit.	No
Willow	Big Bend	12	2	2	Leave as is, won't be an accessible picnic unit.	No
Willow	Washago Pond	12	2	1	Leave as is, won't be an accessible picnic unit.	No
Willow	Flint Woods	13	4	1	Leave as is, won't be an accessible picnic unit.	No
Willow	Washago Pond	13	3	0	Leave as is, won't be an accessible picnic unit.	No
Willow	Flint Woods	14	3	1	Leave as is, won't be an accessible picnic unit.	No
Willow	Washago Pond	14	3	1	Leave as is, won't be an accessible picnic unit.	No
Willow	Big Bend	15	3	1	Leave as is, won't be an accessible picnic unit.	No
Willow	Big Bend	16	1	1	Leave as is, won't be an accessible picnic unit.	No
Willow	Big Bend	17	6	1	Leave as is, won't be an accessible picnic unit.	No
Willow	Big Bend	18	4	1	Leave as is, won't be an accessible picnic unit.	No
Willow	Pool Activity Center		1	0	Not a picnic unit at the moment. Develop accessible picnic units around pool per the redevelopment plan. Several accessible units to be constructed.	No
Willow	Pool Activity Center		1	0	Not a picnic unit at the moment. Develop accessible picnic units around pool per the redevelopment plan. Several accessible units to be constructed.	No
Willow	Pool Activity Center		1	0	Not a picnic unit. Count table with the shelter unit and increase the accessible table ratio under the shelter.	No
Willow	Pool Activity Center		2	0	Not a picnic unit. Count tables with the shelter unit and increase the accessible table ratio under the shelter.	No
Willow	Service Yard		0	2	Not a picnic unit. Grills are used by Metropark staff.	No
Willow	Elder Creek		1	0	Not a picnic unit. Move table to a picnic unit.	No
Willow	Flint Woods		1	1	Not a picnic unit. Recommend moving the table and grill to a picnic unit.	No
Willow	Elder Creek		1	1	Not a picnic unit. Relocate table and grill to a picnic unit.	No
Willow	Big Bend		1	0	Not a picnic unit. Relocate table to a picnic unit.	No
Willow	Chestnut		1	0	Not a picnic unit. Relocate table to a picnic unit.	No
Willow	Chestnut		1	0	Not a picnic unit. Relocate table to a picnic unit.	No
Willow	Elder Creek		1	0	Not a picnic unit. Relocate table to a picnic unit.	No
Willow	Elder Creek		1	0	Not a picnic unit. Relocate table to a picnic unit.	No
Willow	Fox Meadows		1	0	Not a picnic unit. Relocate table to a picnic unit.	No
Willow	Pool Activity Center		1	0	Not a picnic unit. Relocate table to a picnic unit.	No
Willow	Washago Pond		1	0	Not a picnic unit. Relocate table to a picnic unit.	No
Willow	Washago Pond		1	0	Not a picnic unit. Relocate table to a picnic unit.	No
Willow	Washago Pond		1	0	Not a picnic unit. Relocate table to a picnic unit.	No

Willow	Washago Pond	1	0	Not a picnic unit. Relocate table to a picnic unit.	No
Willow	Washago Pond	1	0	Not a picnic unit. Relocate table to a picnic unit.	No
Willow	Fox Meadows	2	0	Not a picnic unit. Relocate tables to the south shelter unit and count tables when calculating necessary accessible table ratio under shelter.	No
Willow	Chestnut	24	0	Not a picnic unit. Spectator / Team area for cross country running events. Accessible team and spectator seating areas needed. Combine all 3 areas. Eight accessible tables needed. Locate tables off the existing walks.	No
Willow	Chestnut	14	0	Not a picnic unit. Spectator area for cross country running events. Accessible team and spectator seating areas needed. Combine all 3 areas. Eight accessible tables needed. Locate tables off the existing walks.	No
Willow	Chestnut	40	1	Not a picnic unit. Spectator area for cross country running events. Accessible team and spectator seating areas needed. Combine all 3 areas. Eight accessible tables needed. Locate tables off the existing walks. Relocate grill to a picnic unit.	No
Willow	Service Yard	1	0	Not a picnic unit. Table is used by Metropark staff.	No
Willow	Service Yard	1	0	Not a picnic unit. Table is used by Metropark staff.	No
Willow	Service Yard	7	0	Not a picnic unit. Tables are stored for repair or disposal.	No
Willow	Service Yard	45	0	Not a picnic unit. Tables are stored for repair or disposal.	No
Willow	Service Yard	2	0	Not a picnic unit. Tables are used to hold up the Voyageur Canoe.	No
Willow	Washago Pond	10	0	Not a picnic unit. The Boat Rental Building will be evaluated separately. Tables and chairs are moveable and appear to meet accessibility standards.	No
Willow	Washago Pond	2	0	Not a picnic unit. The Boat Rental Building will be evaluated separately. Two accessible tables needed.	No
Willow	Disc Golf Course	2	1	Not a picnic unit. The Disc Golf Course will be evaluated separately. An accessible table and grill are needed. An access path will be needed from the parking lot.	No
Willow	Pool Activity Center	14	0	Not a picnic unit. The Food Bar will be evaluated separately. Tables and chairs are moveable and appear to meet accessibility requirements.	No
Willow	Golf Course	1	0	Not a picnic unit. The Golf Course will be evaluated separately. An accessible table needed. An accessible access route is needed from the Starter Building to the picnic table.	No
Willow	Golf Course	23	0	Not a picnic unit. The Golf Course will be evaluated separately. Meet table accessible ratio requirements. Recommend that the table styles match. There are three styles currently.	No
Willow	Golf Course	3	0	Not a picnic unit. The Golf Course will be evaluated separately. Two accessible tables needed at the "turn" area. Recommend that the table styles match. Matching tables available at the Starter Building Patio.	No

Picnic Unit Ranking Within Metropark

Metropark	Picnic Facility	Picnic Unit Ranking Within Metropark	Picnic Unit Ranking Within Picnic Facility	Picnic Unit Number Within Facility	Number of Tables	Number of Grills	Recommendations	Meets ADA Currently
Lower Huron	Ellwoods	1	1	5	15	2	Ellwoods West Shelter (F) is the most rented shelter in area. Combine some tables counted surrounding shelter in picnic units 4 and 6 when calculating necessary accessible table ratio under shelter. The two existing grills need to be accessible.	No
Lower Huron	Foxwoods	2	1	3	20	2	Foxwoods Picnic Shelter (I) is the only rental shelter in this area. Meet ratio requirements for accessible tables under shelter. Both grills need to be accessible.	No
Lower Huron	Hawthorn Glade	3	1	2	24	2	The Hawthorn Glade North Picnic Shelter (D) is the most rented shelter in this area. Both grills need to be accessible. An accessible walk is needed to the restroom building and Turtle Cove.	No
Lower Huron	Ellwoods	4	2	10	9	2	Ellwoods East Shelter (G) is the second most rented shelter in this area. The two existing grills need to be accessible. Accessible routes needed to playground, restroom, and Turtle Cove.	No
Lower Huron	Woods Creek	5	1	5	27	2	Woods Creek South Shelter (C) is the most rented shelter in this area. Meet ratio requirements for accessible tables under shelter. The two existing grills need to be accessible, both are located on pavement along an accessible route.	No
Lower Huron	Tulip Tree	6	1	2	14	1	Tulip Tree Picnic Shelter (A) is only rental shelter in area. Count some tables surrounding shelter when calculating necessary accessible table ratio under shelter. The grill needs to be accessible. Access walk needed to restroom building.	No
Lower Huron	Hawthorn Glade	7	2	6	23	2	The Hawthorn Glade South Picnic Shelter (E) is the second most rented shelter in this area. Both grills need to be accessible. An accessible walk is needed to the shelter and to the restroom building and Turtle Cove.	No
Lower Huron	Sycamore Bend	8	1	3	15	0	Sycamore Bend Picnic Shelter (H) is only rental shelter in area. Combine tables counted surrounding shelter in picnic units 4 and 5 when calculating necessary accessible table ratio under shelter. An accessible grill is needed close to shelter.	No
Lower Huron	Woods Creek	9	2	6	8	2	Woods Creek North Shelter (B) is the second most rented shelter in this area. Two accessible tables needed. Both grills need to be accessible.	No
Lower Huron	Ellwoods	10	4	4	18	6	Count some tables w/ shelter unit and increase ADA table ratio under shelter. Meet ratio requirements for ADA tables / grills. Add necessary accessible routes. Two existing tables were intended to meet ADA.	No
Lower Huron	Ellwoods	11	3	6	18	5	Count some tables w/ shelter unit and increase ADA table ratio under shelter. Meet ratio requirements for ADA tables / grills. Add necessary accessible routes.	No

Lower Huron	Woods Creek	12	3	2	19	6	Count some tables w/ shelter unit and increase ADA table ratio under shelter. Locate accessible tables and grills off the existing path. Has an accessible route to restrooms through parking lot.	No
Lower Huron	Tulip Tree	13	2	1	13	4	Count some tables w/ shelter unit and increase ADA table ratio under shelter.	No
Lower Huron	Sycamore Bend	14	2	4	0	2	Count grills as part of the shelter unit. Both grills need to be accessible and closer to the shelter.	No
Lower Huron	North Fishing Site	15	1	1	1	1	Combine picnic units 1 and 2. Two accessible tables needed. Two accessible grills needed. Will be updated as part of an awarded grant project.	No
Lower Huron	North Fishing Site	16	2	2	6	3	Combine with picnic unit 1.	No
Lower Huron	Turtle Cove	17	1	1	14	2	Meet ratio requirements for accessible tables. One of the tables is accessible. Both of the grills need to be accessible. Develop walkway to Ellwoods and located the accessible tables and grills along the walk.	No
Lower Huron	East Bend	18	1	1	10	2	Two accessible tables needed and two accessible grills needed. Locate off of existing path to fishing pier.	No
Lower Huron	Bob White	19	1	1	3	1	Two accessible tables needed. The grill needs to be accessible.	No
Lower Huron	Turtle Cove	20	2	2	5	1	Two accessible tables needed. One of the tables is located along a walk and is accessible. The grill needs to be accessible.	No
Lower Huron	Foxwoods	21	2	1	35	10	Divide area into two picnic units. Make the unit closest to the restroom building accessible. Meet ratio requirements for tables and grills. Recommend an accessible route across the park road to Turtle Cove.	No
Lower Huron	Sycamore Bend	22	3	2	4	1	Two accessible tables needed. The grill needs to be accessible. Locate the accessible tables and grill along the existing walk.	No
Lower Huron	East Bend	23	2	2	8	0	Two accessible tables needed. Locate off of existing path to restroom building.	No
Lower Huron	Tulip Tree	24	3	4	3	1	Two accessible tables needed. The grill needs to be accessible. Locate the accessible tables and grill along the existing walk or new walk proposed to the Tulip Tree shelter.	No
Lower Huron	South Fishing Site	25	1	2	1	1	Combine both units so there is only one picnic unit at this location. Two accessible tables and grills to be located along the existing path to the fishing pier.	No
Lower Huron	South Fishing Site	26	2	1	1	0	Combine both units so there is only one picnic unit at this location. Two accessible tables and grills to be located along the existing path to the fishing pier.	No
Lower Huron	Hawthorn Glade	27	3	3	11	3	Relocate one table to another picnic unit. Reduce table count to 10 max. Two accessible tables and grills are needed after relocating table. An accessible walk will be needed to this area extending to the restroom building and on to Turtle Cove.	No

Lower Huron	Foxwoods	28	3	2	5	1	Two accessible tables needed. The grill needs to be accessible. Locate tables and grills off existing walks.	No
Lower Huron	Tulip Tree	29	4	5	8	2	Two accessible tables needed. Both grills need to be accessible. Locate accessible tables and grills along the existing walk and hike-bike trail.	No
Lower Huron	Sycamore Bend	30	4	5	6	2	Two accessible tables and grills needed. Locate the accessible grills and tables along a new walk that extends to the restroom building.	No
Lower Huron	Ellwoods	31	5	11	9	2	Two accessible tables needed. Both grills need to be accessible.. Locate the accessible tables and grills along a new accessible route connecting the parking lot, playground, restroom building, and Turtle Cove.	No
Lower Huron	Ellwoods	32	6	12	9	3	Two accessible tables needed. Two accessible grills needed. Locate the accessible tables and grills along a new accessible route connecting the parking lot, playground, restroom building, and Turtle Cove.	No
Lower Huron	Hawthorn Glade	33	4	4	6	2	Two accessible tables and grills needed. Locate off the proposed walk connecting the parking lot, shelter, restroom building, and Turtle Cove.	No
Lower Huron	Woods Creek	34	4	7	10	2	Two accessible tables needed. Both grills need to be accessible. Access walks needed connecting parking lot, picnic tables / grills, and restroom building.	No
Lower Huron	Ellwoods			1	6	1	Leave as is, won't be an accessible picnic unit.	No
Lower Huron	Hawthorn Glade			1	2	1	Leave as is, won't be an accessible picnic unit.	No
Lower Huron	Sycamore Bend			1	4	1	Leave as is, won't be an accessible picnic unit.	No
Lower Huron	Woods Creek			1	3	1	Leave as is, won't be an accessible picnic unit.	No
Lower Huron	Ellwoods			2	9	3	Leave as is, won't be an accessible picnic unit.	No
Lower Huron	Ellwoods			3	6	2	Leave as is, won't be an accessible picnic unit.	No
Lower Huron	Tulip Tree			3	10	3	Leave as is, won't be an accessible picnic unit.	No
Lower Huron	Turtle Cove			3	4	0	Leave as is, won't be an accessible picnic unit.	No
Lower Huron	Woods Creek			3	9	3	Leave as is, won't be an accessible picnic unit.	No
Lower Huron	Foxwoods			4	4	1	Leave as is, won't be an accessible picnic unit.	No
Lower Huron	Woods Creek			4	5	2	Not a picnic unit. Relocate tables and grills to another picnic unit outside the parking lot island.	No
Lower Huron	Foxwoods			5	4	1	Leave as is, won't be an accessible picnic unit.	No
Lower Huron	Hawthorn Glade			5	3	1	Leave as is, won't be an accessible picnic unit.	No
Lower Huron	Tulip Tree			6	2	1	Leave as is, won't be an accessible picnic unit.	No
Lower Huron	Ellwoods			7	21	7	Leave as is, won't be an accessible picnic unit.	No
Lower Huron	Tulip Tree			7	2	2	Leave as is, won't be an accessible picnic unit.	No
Lower Huron	Ellwoods			8	27	8	Leave as is, won't be an accessible picnic unit.	No
Lower Huron	Woods Creek			8	3	0	Leave as is, won't be an accessible picnic unit.	No
Lower Huron	Ellwoods			9	24	4	Leave as is, won't be an accessible picnic unit.	No
Lower Huron	Ellwoods				1	0	Not a picnic unit.	No
Lower Huron	Sycamore Bend				1	0	Not a picnic unit. Count table as part of the shelter unit and increase accessible table ratio under shelter.	No

Lower Huron	Turtle Cove	21	0	Not a picnic unit. Food Bar area at Turtle Cove Family Aquatic Center will be evaluated separately. Meet ratio requirements for accessible tables.	No
Lower Huron	Turtle Cove	4	0	Not a picnic unit. Food Bar area outside Turtle Cove Family Aquatic Center will be evaluated separately. Two accessible tables needed.	No
Lower Huron	Walnut Grove Campground	1	0	Not a picnic unit. Relocate table to a campsite or another picnic unit. Table may have been moved by campers.	No
Lower Huron	Tulip Tree	1	0	Not a picnic unit. Relocate table to a picnic unit.	No
Lower Huron	Turtle Cove	1	0	Not a picnic unit. Relocate table to a picnic unit.	No
Lower Huron	Woods Creek	1	0	Not a picnic unit. Relocate table to a picnic unit.	No
Lower Huron	Turtle Cove	12	4	Not a picnic unit. Rental areas at Turtle Cove Family Aquatic Center will be evaluated separately. Three tables and one grill are located at each rental area. Two tables and the grill in each unit need to be accessible.	No
Lower Huron	Walnut Grove Campground	3	0	Not a picnic unit. The campground and campground playground will be evaluated separately. Two accessible tables needed. Accessible walk needed to playground and nearby restroom building.	No
Lower Huron	Walnut Grove Campground	6	2	Not a picnic unit. The campground will be evaluated separately. Two accessible tables needed. Both grills need to be accessible.	No
Lower Huron	Turtle Cove	4	0	Not a picnic unit. Turtle Cove Family Aquatic Center will be evaluated separately. Birthday party rental shelter at Turtle Cove. Two accessible tables needed.	No

Picnic Unit Ranking Within Metropark

Metropark	Picnic Facility	Picnic Unit Ranking Within Metropark	Picnic Unit Ranking Within Picnic Facility	Picnic Unit Number Within Facility	Number of Tables	Number of Grills	Recommendations	Meets ADA Currently
Delhi	East Delhi	1	1	6	12	0	The West Picnic Shelter (A) is the only picnic shelter in the area. Count some tables surrounding shelter when calculating necessary accessible table ratio under shelter. An accessible grill is needed and should be located closer to shelter.	No
Delhi	East Delhi	2	2	5	24	2	Count some tables w/ shelter unit and increase ADA table ratio under shelter. The remaining tables and grills can remain as is, won't be an accessible picnic area.	No
Delhi	East Delhi	3	3	2	4	2	Combine picnic units 2 and 3. Two accessible tables and grills needed when combined. Locate close to playground with connected access to restrooms and parking.	No
Delhi	East Delhi	4	4	3	2	0	Combine picnic units 2 and 3. Two accessible tables and grills needed when combined. Locate close to playground with connected access to restrooms and parking.	No
Delhi	East Delhi	5	5	1	6	2	Two accessible tables and grills needed. Locate off the proposed hike-bike trail that is being planned.	No
Delhi	East Delhi	6	6	8	2	1	Two accessible tables needed. The grill needs to be accessible. This unit was added because of the baseball field.	No
Delhi	West Delhi	7	1	1	1	2	Combine both units at West Delhi. Two accessible tables and two accessible grills needed when combined. Locate off the proposed hike-bike trail that is being planned. Accessible route needed to vault latrines.	No
Delhi	West Delhi	8	2	2	3	2	Combine both units at West Delhi. Two accessible tables and two accessible grills needed when combined. Locate off the proposed hike-bike trail that is being planned. Accessible route needed to vault latrines.	No
Delhi	Canoe/ Kayak Livery	9		1	2	0	Two accessible tables needed. Locate off the proposed hike-bike trail that is being planned.	No
Delhi	East Delhi			4	4	1	Leave as is, won't be an accessible picnic unit.	No
Delhi	East Delhi			7	6	4	Leave as is, won't be an accessible picnic unit.	No
Delhi	Canoe/ Kayak Livery				2	0	Not a picnic unit. Canoe Livery will be evaluated separately.	No
Delhi	Canoe/ Kayak Livery				1	0	Not a picnic unit. Canoe Livery will be evaluated separately.	No
Delhi	Canoe/ Kayak Livery				4	0	Not a picnic unit. Canoe Livery will be evaluated separately.	No

Picnic Unit Ranking Within Metropark

Metropark	Picnic Facility	Picnic Unit Ranking Within Metropark	Picnic Unit Ranking Within Picnic Facility	Picnic Unit Number Within Facility	Number of Tables	Number of Grills	Recommendations	Meets ADA Currently
Dexter-Huron	Dexter-Huron East	1	1	2	12	0	The Central Picnic Shelter (B) is the most rented shelter on this side of the park. Count some of the tables from picnic unit 7 when calculating necessary accessible table ratio under shelter. An accessible grill is needed close to the shelter.	No
Dexter-Huron	Dexter-Huron East	2	2	5	16	0	The East Picnic Shelter (C) is the second most rented shelter on this side of the park. An access walk is needed to the shelter. An accessible grill is needed close to the shelter.	No
Dexter-Huron	Dexter-Huron West	3	1	5	6	0	The West Picnic Shelter (A) is the most rented shelter on this side of park. Count all tables from unit 4 when calculating necessary accessible table ratio under shelter. Two long tables were counted as 6. Accessible grill needed close to shelter.	No
Dexter-Huron	Dexter-Huron East	4	3	1	7	5	Count some tables w/ shelter unit and increase ADA table ratio under shelter. Two accessible tables and grills needed. A Natural Rivers Permit will be required.	No
Dexter-Huron	Dexter-Huron West	5	2	4	3	1	Count with picnic shelter unit. An accessible grill is needed. Grill was not counted with shelter because it was too far away.	No
Dexter-Huron	Dexter-Huron West	6	3	3	6	3	Two accessible tables and grills needed. Locate off the hike-bike trail. Natural Rivers Permit required.	No
Dexter-Huron	Dexter-Huron West	7	4	1	7	3	Two accessible tables and grills needed. Locate off the new walk (Iron Belle Trail Grant) to be constructed from the west parking lot. A Natural Rivers Permit will be required.	No
Dexter-Huron	Dexter-Huron East	8	4	3	6	2	Two accessible tables and grills needed. Locate off new walk to be constructed to the East Shelter. Natural Rivers permit will be required.	No
Dexter-Huron	Dexter-Huron West			2	5	3	Leave as is, won't be an accessible picnic unit.	No
Dexter-Huron	Dexter-Huron East			4	3	1	Leave as is, won't be an accessible picnic unit.	No
Dexter-Huron	Dexter-Huron West			6	0	1	Leave as is, won't be an accessible picnic unit. Recommend moving grill further from restroom building or removing grill completely.	No
Dexter-Huron	Dexter-Huron West			7	3	2	Leave as is, won't be an accessible picnic unit.	No
Dexter-Huron	Dexter-Huron East				0	2	Not a picnic unit. Grills were too far from shelter to count with it. Relocate closer to shelter.	No
Dexter-Huron	Dexter-Huron East				1	0	Not a picnic unit. Relocate table to a picnic unit.	No

Picnic Unit Ranking Within Metropark

Metropark	Picnic Facility	Picnic Unit Ranking Within Metropark	Picnic Unit Ranking Within Picnic Facility	Picnic Unit Number Within Facility	Number of Tables	Number of Grills	Recommendations	Meets ADA Currently
Hudson Mills	Activity Center	1	1	7	22	0	The Activity Center Picnic Shelter (B) is the only shelter in this area. Count some of the tables from picnic unit 8 when calculating necessary accessible table ratio under shelter. Accessible walk needed to shelter.	No
Hudson Mills	River Grove	2	1	11	31	2	The River Grove Picnic Shelter (A) is the only shelter in this area.	No
Hudson Mills	Pine View	3	1	4	18	2	The Pine View Picnic Shelter (C) is the only shelter in the area. Meet the accessible table ratio. Both grills need to be accessible. An accessible path is needed to the shelter and to the vault latrines.	No
Hudson Mills	Activity Center	4	2	6	41	3	Count some tables w/ shelter unit and increase ADA table ratio under shelter. Many tables had been moved here for a large event. Recommend 7 accessible tables and 2 accessible grills. Locate off existing walks and a new walk to the shelter.	No
Hudson Mills	Activity Center	5	3	3	9	0	The Activity Center Patio area is being counted as a picnic unit. Two accessible tables needed.	No
Hudson Mills	Rapids View	6	1	2	4	2	Combine picnic units 1, 2, and 3. Two accessible tables and grills will be needed when combined. Ten tables maximum. This will be addressed as part of a grant project received.	No
Hudson Mills	Rapids View	7	2	3	0	1	Combine picnic units 1, 2, and 3. Two accessible tables and grills will be needed when combined. Ten tables maximum. This will be addressed as part of a grant project received.	No
Hudson Mills	Rapids View	8	3	1	5	1	Combine picnic units 1, 2, and 3. Two accessible tables and grills will be needed when combined. Ten tables maximum. This will be addressed as part of a grant project received.	No
Hudson Mills	River Grove	9	2	9	15	4	Three accessible tables needed. Two accessible grills needed. Locate accessible grills and tables along the existing walk.	No
Hudson Mills	Activity Center	10	4	4	9	0	Two accessible tables needed. Locate off the walk to the existing walk to the playground.	No
Hudson Mills	River Grove	11	3	8	12	2	Move two tables to another picnic unit. Reduce tables in area to 10 max. Two accessible tables and grills needed after relocating other tables.	No
Hudson Mills	Pine View	12	2	3	17	3	Relocate two tables to another picnic unit. Three accessible tables needed after table removals. Two accessible grills needed. Locate accessible tables and grills off a new walk to the shelter.	No
Hudson Mills	Pine View	13	3	1	5	2	Two accessible tables and grills needed. Locate accessible tables and grills off a new walk to the hike-bike trail or off the hike-bike trail.	No
Hudson Mills	Oak Meadows	14	1	1	7	2	Combine picnic 1 & 2. Two accessible tables and grills needed when combined. Accessible walk needed to restrooms.	No

Hudson Mills	Oak Meadows	15	2	2	1	2	Combine picnic 1 & 2. Two accessible tables and grills needed when combined. Accessible walk needed to restrooms.	No
Hudson Mills	River Grove	16	4	1	0	2	Combine picnic units 1, 2, 3, and 4. Remove three tables. Two accessible tables needed when combined. Two accessible grills needed when combined.	No
Hudson Mills	River Grove	17	5	2	4	1	Combine picnic units 1, 2, 3, and 4. Remove three tables. Two accessible tables needed when combined. Two accessible grills needed when combined.	No
Hudson Mills	River Grove	18	6	3	3	1	Combine picnic units 1, 2, 3, and 4. Remove three tables. Two accessible tables needed when combined. Two accessible grills needed when combined.	No
Hudson Mills	River Grove	19	7	4	6	0	Combine picnic units 1, 2, 3, and 4. Remove three tables. Two accessible tables needed when combined. Two accessible grills needed when combined.	No
Hudson Mills	Activity Center			1	2	0	Leave as is, won't be an accessible picnic unit.	No
Hudson Mills	Activity Center			2	4	1	Leave as is, won't be an accessible picnic unit.	No
Hudson Mills	Pine View			2	2	1	Leave as is, won't be an accessible picnic unit.	No
Hudson Mills	Activity Center			5	8	0	Leave as is, won't be an accessible picnic unit.	No
Hudson Mills	River Grove			5	2	1	Leave as is, won't be an accessible picnic unit.	No
Hudson Mills	River Grove			6	2	0	Leave as is, won't be an accessible picnic unit.	No
Hudson Mills	River Grove			7	10	3	Leave as is, won't be an accessible picnic unit.	No
Hudson Mills	Activity Center			8	4	1	Leave as is, won't be an accessible picnic unit.	No
Hudson Mills	River Grove			10	14	3	Leave as is, won't be an accessible picnic unit.	No
Hudson Mills	River Grove			12	3	1	Leave as is, won't be an accessible picnic unit.	No
Hudson Mills	Golf Course				7	0	Not a picnic unit. Golf Course Patio will be evaluated separately as part of the Golf Course Facility.	No
Hudson Mills	Activity Center				1	0	Not a picnic unit. Relocate table to a picnic unit.	No
Hudson Mills	Hike-Bike Trail				1	0	Not a picnic unit. Relocate table to a picnic unit.	No
Hudson Mills	Pine View				1	0	Not a picnic unit. Relocate table to a picnic unit.	No
Hudson Mills	Activity Center				2	0	Not a picnic unit. Relocate tables to a picnic unit.	No
Hudson Mills	Rapids View				2	0	Not a picnic unit. Relocate tables to a picnic unit.	No
Hudson Mills	Activity Center				12	0	Not a picnic unit. The Activity Center will be evaluated separately.	No

Picnic Unit Ranking Within Metropark

Metropark	Picnic Facility	Picnic Unit Ranking Within Metropark	Picnic Unit Ranking Within Picnic Facility	Picnic Unit Number Within Facility	Number of Tables	Number of Grills	Recommendations	Meets ADA Currently
Huron Meadows	Sunset Ridge	1	1	2	10	1	The Sunset Ridge Picnic Shelter (A) is the only shelter in the area. The existing grill needs to be accessible.	No
Huron Meadows	Acorn Ridge	2	1	3	10	0	The Acorn Ridge Picnic Shelter (B) is the only shelter in area. Count some tables from picnic unit 2 when calculating necessary accessible table ratio under shelter. An accessible grill is needed close to shelter. Accessible walks needed.	No
Huron Meadows	Cedar Ridge	3	1	4	11	0	The Cedar Ridge Picnic Shelter (C) is the only shelter in the area. Count some tables from picnic unit 3 when calculating necessary accessible table ratio under shelter. An accessible grill is needed close to shelter.	No
Huron Meadows	Acorn Ridge	4	2	2	20	9	Count some tables w/ shelter unit and increase ADA table ratio under shelter. Divide picnic unit into 2 and make both units accessible with proper ratios. Locate accessible tables and grills off a new walk to the shelter and restroom building.	No
Huron Meadows	Cedar Ridge	5	2	3	3	3	Count all tables with shelter unit and increase ADA table ratio under shelter. Two accessible grills needed. One grill was too far from shelter and counted with this picnic unit.	No
Huron Meadows	Sunset Ridge	6	2	1	10	2	Two accessible tales and grills needed. Locate off existing walk to the fishing pier.	No
Huron Meadows	Sunset Ridge	7	3	4	2	0	Two accessible tables needed. Locate off walk to the playground and restroom building.	No
Huron Meadows	Cedar Ridge	8	3	7	2	1	Two accessible tables needed. One accessible grill needed. Locate along the existing walk to the shelter.	No
Huron Meadows	Cedar Ridge	9	4	6	1	0	Combine picnic units 5 and 6. Two accessible tables needed. Locate off the walk to the existing picnic shelter.	No
Huron Meadows	Cedar Ridge	10	5	5	1	0	Combine picnic units 5 and 6. Two accessible tables needed. Locate off the walk to the existing picnic shelter.	No
Huron Meadows	Acorn Ridge			1	4	3	Leave as is, won't be an accessible picnic unit.	No
Huron Meadows	Cedar Ridge			1	3	1	Leave as is, won't be an accessible picnic unit.	No
Huron Meadows	Cedar Ridge			2	3	1	Leave as is, won't be an accessible picnic unit.	No
Huron Meadows	Sunset Ridge			3	7	3	Leave as is, won't be an accessible picnic unit.	No
Huron Meadows	Sunset Ridge			5	0	0	Leave as is, won't be an accessible picnic unit.	No
Huron Meadows	Cedar Ridge				1	0	Not a picnic unit. Relocate table to a picnic unit.	No
Huron Meadows	Cedar Ridge				2	0	Not a picnic unit. Relocate tables to a picnic unit.	No
Huron Meadows	Golf Course				2	0	Not a picnic unit. The Golf Course Patio area will be evaluated as part of the Golf Course facility.	No

Picnic Unit Ranking Within Metropark

Metropark	Picnic Facility	Picnic Unit Ranking Within Metropark	Picnic Unit Ranking Within Picnic Facility	Picnic Unit Number Within Facility	Number of Tables	Number of Grills	Recommendations	Meets ADA Currently
Kensington	Martindale Beach	1	1	5	22	2	The North Martindale Picnic Shelter is the most rented shelter in the park. Meet ratio requirements for accessible picnic tables under shelter. Both of the grills needed to be accessible. An accessible routes is needed to the beach area.	No
Kensington	East Boat Launch	2	1	5	7	1	The South Martindale Picnic Shelter (B) is the most rented shelter in this area. The grill needs to be accessible. An accessible walk is needed to the vault latrines and to Martindale Beach.	No
Kensington	East Boat Launch	3	2	3	13	1	The East Boat Launch Picnic Shelter (A) is the second most rented shelter in this area. Count some of the tables from unit 2 when calculating necessary accessible table ratio under shelter. The grill needs to be accessible.	No
Kensington	Playfield	4	1	7	19	1	The Playfield East Picnic Shelter (F) is the most rented shelter in this area. Count some tables from units 6 and 8 when calculating ratio requirements under shelter. The grill needs to be accessible.	No
Kensington	West Boat Launch	4	4	2	8	1	Two accessible tables needed. The grill needs to be accessible.	No
Kensington	West Boat Launch	5	1	7	19	1	The West Boat Launch Picnic Shelter (O) is the most rented shelter in this area. A grant proposal was submitted to make the shelter accessible and to add an accessible restroom nearby.	No
Kensington	Orchard	6	1	2	21	3	The Orchard Picnic Shelter (J) is the only rental shelter in this area. Count some tables from unit 1 when calculating table ratio requirements under shelter. Two of the grills need to be accessible.	No
Kensington	North Hickory	7	1	3	18	1	Evaluate both Hickory areas as one picnic facility. The North Hickory Ridge Picnic Shelter (M) is most rented shelter in area. Count some of the tables from unit 5 when calculating table ratio under shelter. Access walk needed to restrooms.	No
Kensington	Playfield	8	2	18	19	2	The Playfield West Picnic Shelter (H) is the second most rented shelter in this area. Count all tables from unit 17 when calculating ratio requirements under shelter. Both grills need to be accessible. Access walk needed to parking and restrooms.	No
Kensington	Playfield	9	3	15	8	2	The Playfield Center Picnic Shelter (G) is the third most rented shelter in this area. Both grills need to be accessible.	No
Kensington	Possum Hollow	10	1	3	13	1	Possum Hollow Picnic Shelter (I) is only rental shelter in area. Access walks needed connecting lot, shelter, and restroom building. Count some tables from unit 8 when calculating ratio requirements under shelter. The grill needs to be accessible.	No

Kensington	South Hickory	11	2	10	6	1	Evaluate both Hickory areas as one picnic facility. South Hickory Ridge Picnic Shelter (N) is second most rented shelter in area. Count all tables and grill from unit 12 when calculating table ratio under shelter. Access walk needed to restrooms.	No
Kensington	Spring Hill	12	1	4	16	3	The Spring Hill Picnic Shelter (K) is the only rental shelter in this area. Count all tables surrounding the shelter when calculating table ratio requirements under shelter. Two of the grills need to be accessible.	No
Kensington	Spring Hill	13	2	5	16	1	Count all tables with the shelter unit when calculating table ratio under the shelter.	No
Kensington	Baywoods	14	1	1	12	1	The Baywoods Picnic Shelter (L) is the only rental shelter in the area. Count all tables surrounding the shelter when calculating table ratio under shelter. The grill needs to be accessible. Access walk needed to parking lot and restroom building.	No
Kensington	Windfall Hill	15	1	4	12	1	Windfall Hill Picnic Shelter ((D) is only rental shelter in area. Count all tables surrounding shelter when calculating table ratio requirements at shelter. Grill needs to be accessible. Access walk needed. Metroparks considering removal of area.	No
Kensington	Farm Center	16	1	6	7	0	The Farm Center Shelter is the only shelter in the area. This is not a rental shelter. Two accessible tables needed.	No
Kensington	Orchard	17	2	1	4	0	Count all tables with the shelter unit when calculating table ratio under the shelter.	No
Kensington	North Hickory	18	3	4	9	0	Count some of the tables with shelter unit and increase ADA table ratio under shelter. Access walk needed to restroom building.	No
Kensington	Playfield	19	5	17	17	1	Count all tables with the shelter unit when calculating table ratio under the shelter.	No
Kensington	Possum Hollow	20	2	2	8	0	Count some of the tables with the shelter unit. The remaining tables will have to be evaluated as a picnic unit. Two accessible tables needed. Locate along new access routed to the restroom building and parking lot.	No
Kensington	Baywoods	21	2	2	7	0	Count all tables with shelter unit and increase ADA table ratio under shelter. Access walk needed to parking lot and restroom building.	No
Kensington	Windfall Hill	22	2	3	8	0	Count all tables with the shelter unit when calculating table ratio under the shelter. Metroparks considering removal of picnic area.	No
Kensington	Maple Beach	23	1	3	16	1	Remove one table from the picnic unit, 15 max. Three accessible tables needed after removal. The grill needs to be accessible.	No
Kensington	Turtlehead	24	1	6	19	5	Four accessible tables needed. Two accessible grills needed. Locate near parking lot along a new access walk to the restroom building.	No

Kensington	Shore Fishing	25	1	1	12	0	Combine units 1 and 2. Remove three tables. Twenty tables max. within unit. Four accessible tables needed after removals. Two accessible grills recommended. Access to the vault latrines is needed.	No
Kensington	Lower Farm Center	26	1	2	5	0	Combine picnic units 1 and 2. Remove one table, 10 max. Two accessible tables needed when combined. Locate the accessible tables off a new accessible walk that connects to the Upper Farm Center.	No
Kensington	Island Road Roadside Parking	27	1	3	7	1	Two accessible picnic units needed at Island Road. Need to split this area into two or add parking at another area. Recommend splitting and making both units accessible. Four accessible tables needed. Recommend 2 accessible grills.	No
Kensington	Martindale Beach	28	2	4	25	3	Five accessible tables needed. Two accessible grills needed. Locate the accessible tables and grills off the existing walk and new walk to the beach area.	No
Kensington	Farm Center	29	2	5	23	0	Five accessible tables needed. Locate along the existing path.	No
Kensington	West Boat Launch	30	2	8	13	1	Remove three tables in this area. Grant will update this area with two accessible tables and grills.	No
Kensington	Maple Beach	31	2	4	4	1	Two accessible tables needed. The grill needs to be accessible.	No
Kensington	Turtlehead	32	3	1	2	1	Combine units 1,2, and 4. Limit tables to 10 max. within unit. Two accessible tables and grills needed after combining. Locate off a new access walk to the restroom building and parking lot.	No
Kensington	Turtlehead	33	2	2	1	1	Combine units 1,2, and 4. Limit tables to 10 max. within unit. Two accessible tables and grills needed after combining. Locate off a new access walk to the restroom building and parking lot.	No
Kensington	Shore Fishing	34	2	2	11	1	Combine units 1 and 2. Remove three tables. Twenty tables max. within unit. Four accessible tables needed after removals. Two accessible grills recommended. Access to the vault latrines is needed.	No
Kensington	Turtlehead	35	4	4	9	1	Combine units 1,2, and 4. Limit tables to 10 max. within unit. Two accessible tables and grills needed after combining. Locate off a new access walk to the restroom building and parking lot.	No
Kensington	Lower Farm Center	36	2	1	6	0	Combine picnic units 1 and 2. Remove one table, 10 max. Two accessible tables needed when combined. Locate the accessible tables off a new accessible walk that connects to the Upper Farm Center.	No
Kensington	Farm Center Overflow Lot	37	1	1	1	0	Combine units 1 and 2 at the unit 1 location. Two accessible tables needed when combined.	No
Kensington	Farm Center Overflow Lot	38	2	2	1	0	Combine units 1 and 2 at the unit 1 location. Two accessible tables needed when combined.	No
Kensington	Flagstaff	39	1	2	6	1	Split area into two accessible units. Four accessible tables needed. Recommend 2 accessible grills.	No

Kensington	Martindale Beach	40	3	1	32	6	Meet ratio requirements for accessible tables and grills. Some can be located off the existing walk. Access walk needed from South Martindale / East Boat Launch to the beach area and to the nearby vault latrines.	No
Kensington	Farm Center	41	3	1	5	0	Two accessible tables needed. Locate next to existing walk.	No
Kensington	West Boat Launch	42	3	5	13	1	Remove three tables from this unit. Two accessible tables needed. The grills needs to be accessible. Locate the accessible tables and grill off the existing walks.	No
Kensington	East Boat Launch	43	3	1	38	3	Divide picnic unit in half and make one of the units accessible. Locate 4 accessible tables and 2 grills off the existing walk.	No
Kensington	Orchard	44	3	5	7	1	Two accessible picnic units. Two accessible grills recommended. Locate off walk to restroom building.	No
Kensington	Possum Hollow	45	3	1	14	1	Three accessible tables needed. The grill needs to be accessible. Access walk needed to shelter.	No
Kensington	Spring Hill	46	3	3	5	1	Two accessible tables needed. One accessible grill needed. Locate the accessible tables and grill off existing walks.	No
Kensington	Baywoods	47	3	4	14	3	Combine picnic units 3 and 4. Four accessible tables and two accessible grills needed when combined.	No
Kensington	Baywoods	48	4	3	6	1	Combine picnic units 3 and 4. Four accessible tables and two accessible grills needed when combined.	No
Kensington	Island Road	49	1	1	15	2	Three accessible tables needed. Two accessible grills needed. Locate near the parking lot with access to the restroom building.	No
Kensington	Windfall Hill	50	3	2	5	0	Two accessible tables needed. Locate accessible tables off a new walk to the picnic shelter Metroparks considering removal of picnic area.	No
Kensington	East Boat Launch	51	4	4	24	3	Five accessible tables and 2 accessible grills needed. Locate off the existing path or hike-bike trail.	No
Kensington	Orchard	52	4	7	21	4	Divide large picnic unit in half with 10 tables each. Remove one table. Make one of the two picnic units accessible with two accessible tables and grills. Locate the accessible tables and grills off a new walk to the restroom building.	No
Kensington	Playfield	53	4	2	8	1	The Playfield North Picnic Shelter (E) is the least rented shelter in this area. Meet ADA table ratio requirements under shelter. The grill needs to be accessible. Needs access walk to the vault latrines.	No
Kensington	South Hickory	54	4	11	12	1	Tables & grill next to shelter, counted separate. Place enough ADA tables at shelter for both areas.	No
Kensington	Spring Hill	55	4	1	4	1	Two accessible tables needed. One accessible grill needed. Locate the accessible tables and grill off a new walk to the restroom building.	No
Kensington	East Boat Launch	56	5	7	9	3	Two accessible tables and grills needed. Locate near the parking lot. A new accessible walk is needed to the vault latrines.	No
Kensington	Playfield	57	12	10	10	0	Two accessible tables needed. Two accessible grills recommended.	No

Kensington	South Hickory	58	5	7	8	1	Two accessible tables needed. The grill needs to be accessible.	No
Kensington	Playfield	59	10	23	12	1	Relocate two tables to another picnic unit. Ten tables max. Two accessible tables needed after removal. Two accessible grills recommended. Locate the accessible tables and grills off new walks to other shelters and the restroom building.	No
Kensington	Playfield	60	6	24	2	1	Combine picnic units 24, 25, 26, and 27. Limit to 15 tables max. Three accessible tables needed when combined. Two accessible grills recommended. Locate accessible tables and grills off existing walks.	No
Kensington	Playfield	61	7	25	3	0	Combine picnic units 24, 25, 26, and 27. Limit to 15 tables max. Three accessible tables needed when combined. Two accessible grills recommended. Locate accessible tables and grills off existing walks.	No
Kensington	Playfield	63	11	1	17	1	Divide unit in half. Make one of the two an accessible picnic unit with two accessible tables and an accessible grill. Access walk needed to the vault latrines.	No
Kensington	Playfield	64	8	26	4	1	Combine picnic units 24, 25, 26, and 27. Limit to 15 tables max. Three accessible tables needed when combined. Two accessible grills recommended. Locate accessible tables and grills off existing walks.	No
Kensington	Playfield	65	9	27	7	0	Combine picnic units 24, 25, 26, and 27. Limit to 15 tables max. Three accessible tables needed when combined. Two accessible grills recommended. Locate accessible tables and grills off existing walks.	No
Kensington	South Hickory	66	6	13	3	0	Combine picnic units 12, 13, and 15. Limit table total to 10 max. Two accessible tables needed when combined. Access walks needed to parking lot and restrooms. Add two accessible grills.	No
Kensington	South Hickory	67	7	12	2	0	Combine picnic units 12, 13, and 15. Limit table total to 10 max. Two accessible tables needed when combined. Access walks needed to parking lot and restrooms. Add two accessible grills.	No
Kensington	South Hickory	68	8	15	7	0	Combine picnic units 12, 13, and 15. Limit table total to 10 max. Two accessible tables needed when combined. Access walks needed to parking lot and restrooms. Add two accessible grills.	No
Kensington	Windfall Hill	69	4	1	11	3	Remove one table. Ten tables max. within the picnic unit. Two accessible tables needed after removal. Two accessible grills needed. Access walk needed to vault latrines. Metroparks considering removal of picnic area.	No
Kensington	Flagstaff			1	2	1	Leave as is, won't be an accessible picnic unit.	No
Kensington	Island Road Roadside Parking			1	2	0	Leave as is, won't be an accessible picnic unit.	No
Kensington	Maple Beach			1	3	0	Leave as is, won't be an accessible picnic unit.	No
Kensington	North Hickory			1	6	2	Leave as is, won't be an accessible picnic unit.	No
Kensington	West Boat Launch			1	3	1	Leave as is, won't be an accessible picnic unit.	No

Kensington	East Boat Launch	2	17	0	Leave as is, won't be an accessible picnic unit.	No
Kensington	Island Road Roadside Parking	2	7	1	Leave as is, won't be an accessible picnic unit.	No
Kensington	Maple Beach	2	5	1	Leave as is, won't be an accessible picnic unit.	No
Kensington	Martindale Beach	2	8	0	Leave as is, won't be an accessible picnic unit.	No
Kensington	North Hickory	2	3	0	Leave as is, won't be an accessible picnic unit.	No
Kensington	Spring Hill	2	3	0	Leave as is, won't be an accessible picnic unit.	No
Kensington	Farm Center	2	3	0	Not a picnic unit. The Farmhouse Grille and patio area will be evaluated separately. All three tables are accessible.	Yes
Kensington	Flagstaff	3	3	1	Leave as is, won't be an accessible picnic unit.	No
Kensington	Martindale Beach	3	4	1	Leave as is, won't be an accessible picnic unit.	No
Kensington	Orchard	3	10	2	Leave as is, won't be an accessible picnic unit.	No
Kensington	Playfield	3	6	1	Leave as is, won't be an accessible picnic unit.	No
Kensington	Turtlehead	3	8	2	Leave as is, won't be an accessible picnic unit.	No
Kensington	West Boat Launch	3	17	1	Leave as is, won't be an accessible picnic unit.	No
Kensington	Farm Center	3	5	0	Not a picnic unit. The Farmhouse Grille and patio area will be evaluated separately. Two of the five tables are accessible.	Yes
Kensington	Farm Center	4	5	0	Leave as is, won't be an accessible picnic unit.	No
Kensington	Flagstaff	4	6	1	Leave as is, won't be an accessible picnic unit.	No
Kensington	Island Road Roadside Parking	4	2	0	Leave as is, won't be an accessible picnic unit.	No
Kensington	Orchard	4	9	2	Leave as is, won't be an accessible picnic unit.	No
Kensington	Playfield	4	4	0	Leave as is, won't be an accessible picnic unit.	No
Kensington	Possum Hollow	4	3	0	Leave as is, won't be an accessible picnic unit.	No
Kensington	West Boat Launch	4	6	0	Leave as is, won't be an accessible picnic unit.	No
Kensington	Flagstaff	5	10	1	Leave as is, won't be an accessible picnic unit.	No
Kensington	Island Road Roadside Parking	5	7	1	Leave as is, won't be an accessible picnic unit.	No
Kensington	North Hickory	5	4	0	Leave as is, won't be an accessible picnic unit.	No
Kensington	Playfield	5	3	0	Leave as is, won't be an accessible picnic unit.	No
Kensington	Turtlehead	5	23	1	Leave as is, won't be an accessible picnic unit.	No
Kensington	Windfall Hill	5	7	1	Leave as is, won't be an accessible picnic unit. Metroparks considering removal of picnic area.	No
Kensington	East Boat Launch	6	3	1	Leave as is, won't be an accessible picnic unit.	No
Kensington	Martindale Beach	6	20	3	Leave as is, won't be an accessible picnic unit.	No
Kensington	North Hickory	6	10	2	Leave as is, won't be an accessible picnic unit.	No
Kensington	Orchard	6	14	3	Leave as is, won't be an accessible picnic unit.	No
Kensington	Playfield	6	3	0	Leave as is, won't be an accessible picnic unit.	No
Kensington	West Boat Launch	6	7	1	Leave as is, won't be an accessible picnic unit.	No
Kensington	Martindale Beach	7	16	2	Leave as is, won't be an accessible picnic unit.	No
Kensington	South Hickory	8	2	0	Leave as is, won't be an accessible picnic unit.	No
Kensington	Playfield	8	3	0	Leave as is, won't be an accessible picnic unit. Combine picnic units 8 and 9.	No
Kensington	South Hickory	9	5	0	Leave as is, won't be an accessible picnic unit.	No
Kensington	West Boat Launch	9	5	1	Leave as is, won't be an accessible picnic unit.	No
Kensington	Playfield	9	2	1	Leave as is, won't be an accessible picnic unit. Combine picnic units 8 and 9.	No

Kensington	West Boat Launch	10	5	2	Leave as is, won't be an accessible picnic unit.	No
Kensington	Playfield	11	4	1	Leave as is, won't be an accessible picnic unit.	No
Kensington	Playfield	12	2	2	Leave as is, won't be an accessible picnic unit.	No
Kensington	Playfield	13	6	1	Leave as is, won't be an accessible picnic unit.	No
Kensington	Playfield	14	2	1	Leave as is, won't be an accessible picnic unit.	No
Kensington	South Hickory	14	0	0	Leave as is, won't be an accessible picnic unit.	No
Kensington	Playfield	16	2	0	Leave as is, won't be an accessible picnic unit.	No
Kensington	South Hickory	16	5	1	Leave as is, won't be an accessible picnic unit.	No
Kensington	Playfield	19	12	1	Leave as is, won't be an accessible picnic unit.	No
Kensington	Playfield	20	11	1	Leave as is, won't be an accessible picnic unit.	No
Kensington	Playfield	21	3	0	Leave as is, won't be an accessible picnic unit.	No
Kensington	Playfield	22	4	0	Leave as is, won't be an accessible picnic unit.	No
Kensington	Nature Center		9	0	Not a picnic area. Parking is not available. Two accessible tables recommended.	No
Kensington	Lower Farm Center		2	0	Not a picnic facility. The Living History Village Area will be evaluated separately.	No
Kensington	Lower Farm Center		5	0	Not a picnic facility. The Living History Village Area will be evaluated separately. The pavilion needs two accessible tables.	No
Kensington	Flagstaff		1	0	Not a picnic unit.	No
Kensington	Flagstaff		1	0	Not a picnic unit.	No
Kensington	South Hickory		1	0	Not a picnic unit.	No
Kensington	South Hickory		1	0	Not a picnic unit.	No
Kensington	North Hickory		1	0	Not a picnic unit. Move table to another picnic unit.	No
Kensington	Farm Center		2	0	Not a picnic unit. Relocate both tables to a picnic unit.	No
Kensington	Possum Hollow		2	0	Not a picnic unit. Relocate both tables to a picnic unit.	No
Kensington	Turtlehead		0	1	Not a picnic unit. Relocate grill to a picnic unit.	No
Kensington	Lower Farm Center		1	0	Not a picnic unit. Relocate table to a picnic unit or further into the Living History Village area.	No
Kensington	Martindale Beach		1	0	Not a picnic unit. Relocate table to a picnic unit.	No
Kensington	Near Buno Bridge		1	0	Not a picnic unit. Relocate table to a picnic unit.	No
Kensington	Orchard		1	0	Not a picnic unit. Relocate table to a picnic unit.	No
Kensington	Playfield		1	0	Not a picnic unit. Relocate table to a picnic unit.	No
Kensington	Playfield		1	0	Not a picnic unit. Relocate table to a picnic unit.	No
Kensington	Playfield		1	0	Not a picnic unit. Relocate table to a picnic unit.	No
Kensington	Playfield		1	0	Not a picnic unit. Relocate table to a picnic unit.	No
Kensington	Windfall Hill		1	0	Not a picnic unit. Relocate table to a picnic unit.	No
Kensington	Service Yard		2	0	Not a picnic unit. Tables used by Metropark staff.	No
Kensington	Service Yard		2	0	Not a picnic unit. Tables used by Metropark staff.	No
Kensington	Boat Rental		2	0	Not a picnic unit. The Boat Rental will be evaluated separately.	No
Kensington	Boat Rental		4	0	Not a picnic unit. The Boat Rental will be evaluated separately. The tables have moveable furniture.	Yes
Kensington	Disc Golf Course		7	0	Not a picnic unit. The Disc Golf Course and Shelter will be evaluated separately. This is not a rental shelter. Two accessible tables needed. An access walk is needed to the shelter and to the accessible portable toilet.	No

Kensington	Disc Golf Course	4	0	Not a picnic unit. The Disc Golf Course will be evaluated separately. An access walk is needed to the shelter and to the accessible portable toilet. Locate the accessible tables off this proposed walk.	No
Kensington	Lower Farm Center	6	0	Not a picnic unit. The District Garden area was not used in 2019 and may not open for some time.	No
Kensington	East Boat Launch	8	1	Not a picnic unit. The East Boat Launch and Marina will be evaluated separately. Two accessible tables needed. One accessible grill needed. An accessible routes in needed to the nearest restroom building.	No
Kensington	Equestrian Staging	2	0	Not a picnic unit. The Equestrian Staging Area will be evaluated separately. Recommend combing all tables at the concrete pad. Two accessible tables needed when combined.	No
Kensington	Equestrian Staging	2	0	Not a picnic unit. The Equestrian Staging Area will be evaluated separately. Recommend combing all tables at the concrete pad. Two accessible tables needed when combined.	No
Kensington	Equestrian Staging	2	0	Not a picnic unit. The Equestrian Staging Area will be evaluated separately. Relocate away from turn around area. Recommend combing all tables at the concrete pad. Two accessible tables needed when combined.	No
Kensington	West Boat Launch Fishing Pier	2	0	Not a picnic unit. The fishing pier will be evaluated separately. Two accessible tables needed.	No
Kensington	Martindale Beach	16	0	Not a picnic unit. The Food Bar area will be evaluated separately. There are 5 tables and all of them have an accessible sitting space.	Yes
Kensington	Golf Course	12	0	Not a picnic unit. The Golf Course and patio area will be evaluated separately. Ten of the 12 tables are accessible.	Yes
Kensington	Group Camp	6	0	Not a picnic unit. The Group Camp / Equestrian Camp area will be evaluated separately. Two accessible tables needed.	No
Kensington	Group Camp	13	0	Not a picnic unit. The Group Camp area will be evaluated separately.	No
Kensington	Group Camp	8	0	Not a picnic unit. The Group Camp area will be evaluated separately.	No
Kensington	Group Camp	6	0	Not a picnic unit. The Group Camp area will be evaluated separately.	No
Kensington	Group Camp	3	0	Not a picnic unit. The Group Camp area will be evaluated separately.	No
Kensington	Group Camp	16	0	Not a picnic unit. The Group Camp area will be evaluated separately.	No
Kensington	Group Camp	3	0	Not a picnic unit. The Group Camp area will be evaluated separately.	No
Kensington	Group Camp	3	0	Not a picnic unit. The Group Camp area will be evaluated separately.	No
Kensington	Group Camp	5	0	Not a picnic unit. The Group Camp area will be evaluated separately.	No
Kensington	Group Camp	5	0	Not a picnic unit. The Group Camp area will be evaluated separately.	No

Kensington	Group Camp	6	0	Not a picnic unit. The Group Camp area will be evaluated separately.	No
Kensington	Group Camp	3	0	Not a picnic unit. The Group Camp area will be evaluated separately.	No
Kensington	Group Camp	6	0	Not a picnic unit. The Group Camp area will be evaluated separately.	No
Kensington	Group Camp	4	0	Not a picnic unit. The Group Camp area will be evaluated separately.	No
Kensington	Group Camp	1	0	Not a picnic unit. The Group Camp area will be evaluated separately. Relocate table to another Group Camp Location.	No
Kensington	Group Camp	1	0	Not a picnic unit. The Group Camp area will be evaluated separately. Relocate table to another Group Camp Location.	No
Kensington	Boat Rental	1	1	Not a picnic unit. The Marina will be evaluated separately. The table and grill need to be accessible. Locate off the existing walk near the parking lot.	No
Kensington	East Boat Launch	1	0	Not a picnic unit. The Marina will be evaluated separately. The table needs to be accessible.	No
Kensington	Mitten Bay Dockage	7	3	Not a picnic unit. The Marina will be evaluated separately. Two accessible tables and grills needed. An access walks is needed to the vault latrines.	No
Kensington	Boat Rental	8	1	Not a picnic unit. The Marina will be evaluated separately. Two accessible tables needed. The grill needs to be accessible. Locate the accessible tables and grill off the existing walk.	No
Kensington	Park Office	1	0	Not a picnic unit. The Park Office will be evaluated separately. The table is used by staff.	No
Kensington	Martindale Beach	14	0	Not a picnic unit. The Splash 'N'" Blast will be evaluated separately. Two tables are accessible. Three accessible table are needed. One seat can be removed to create the third accessible table.	No
Kensington	Golf Course Maintenance Service Yard	1	0	Not a picnic unit. The table is used by maintenance staff.	No
Kensington	Temporary Disc Golf Course	1	0	Not a picnic unit. The Temporary Disc Golf Course will be evaluated separately. Accessibility accommodations need to be made for programmed events like this. The table needs to be accessible.	No
Kensington	Equestrian Venue	1	0	Not a picnic unit. This Equestrian Venue will be evaluated separately. The table needs to be accessible.	No
Kensington	Lower Farm Center	6	1	Not a picnic unit. Two accessible tables recommended near each of the 4 fire pit areas. The grill needs to be accessible.	No
Kensington	Lower Farm Center	2	1	Not a picnic unit. Two accessible tables recommended near each of the 4 fire pit areas. The grill needs to be accessible.	No
Kensington	Lower Farm Center	5	1	Not a picnic unit. Two accessible tables recommended near each of the 4 fire pit areas. The grill needs to be accessible.	No

Picnic Unit Ranking Within Metropark

Metropark	Picnic Facility	Picnic Unit Ranking Within Metropark	Picnic Unit Ranking Within Picnic Facility	Picnic Unit Number Within Facility	Number of Tables	Number of Grills	Recommendations	Meets ADA Currently
Indian Springs	Meadowlark	1	1	4	18	1	The North Meadowlark Picnic Shelter (B) is the most rented shelter in area. Count all tables from unit 6 when calculating necessary accessible table ratio under shelter. An accessible grill is needed. Access route needed to restrooms and parking.	No
Indian Springs	Meadowlark	2	2	7	15	1	South Meadowlark Picnic Shelter (A) is second most rented shelter in area. Count all tables from unit 3 when calculating necessary accessible table ratio under shelter. An accessible grill is needed. Access route needed to restrooms and parking.	No
Indian Springs	Spray 'n' Play	3	1	4	5	0	One of three small rental shelters in area. Rental totals are combined for all three so it is unclear which is rented the most. Two accessible tables needed. Access walk needed to the shelter. Access walk to Meadowlark restroom building needed.	No
Indian Springs	Spray 'n' Play	4	2	1	5	0	One of three small rental shelters in area. Rental totals are combined for all three so it is unclear which is rented the most. Two accessible tables needed. Access walk needed to the shelter. Access walk to Meadowlark restroom building needed.	No
Indian Springs	Spray 'n' Play	5	3	3	5	0	One of three small rental shelters in area. Rental totals are combined for all three so it is unclear which is rented the most. Two accessible tables needed. Access walk needed to the shelter. Access walk to Meadowlark restroom building needed.	No
Indian Springs	Park Office	6	1	1	10	1	This shelter is not a rental shelter. It is the only shelter in the area. Two accessible tables needed. One accessible grill needed.	No
Indian Springs	Meadowlark	7	3	3	3	0	Count all tables with shelter unit and increase ADA table ratio under shelter.	No
Indian Springs	Meadowlark	8	4	6	7	1	Count all tables with shelter unit and increase ADA table ratio under shelter.	No
Indian Springs	Spray 'n' Play	9	4	5	1	1	The table needs to be accessible. The grill needs to be accessible. This is the only picnic unit with a grill at the Spray 'n' Play. Access walk to the Meadowlark restroom building needed.	No
Indian Springs	Spray 'n' Play	10	5	2	5	0	Two accessible tables needed. Access walk to the Meadowlark restroom building needed.	No
Indian Springs	Meadowlark	11	5	1	9	2	Two accessible tables and grills needed. Locate off hike-bike trail.	No

Indian Springs	Meadowlark	12	6	10	4	2	Two accessible tables and grills needed. Locate off existing path to playground or to a future path to be constructed to the restroom building.	No
Indian Springs	Meadowlark	13	7	8	2	1	Combine picnic units 8 and 9. Two accessible tables needed. One accessible grill needed. Locate off existing walks. Playground location likely to change in the near future.	No
Indian Springs	Meadowlark	13	8	9	4	0	Combine picnic units 8 and 9. Two accessible tables needed. One accessible grill needed. Locate off existing walks. Playground location likely to change in the near future.	No
Indian Springs	Meadowlark			2	1	2	Leave as is, won't be an accessible picnic unit.	No
Indian Springs	Meadowlark			5	3	1	Leave as is, won't be an accessible picnic unit.	No
Indian Springs	Hike-Bike Trail				2	0	Not a picnic facility but should still be accessible.	No
Indian Springs	Spray 'n' Play				1	0	Not a picnic unit. An accessible table recommended near the 2-5 playground area.	No
Indian Springs	Hike-Bike Trail				1	0	Not a picnic unit. Recommend that the table be accessible at this remote location along the hike-bike trail.	No
Indian Springs	Service Yard				30	0	Not a picnic unit. Tables are stacked for repair and will be placed back in the park. Future table locations unknown at this time.	No
Indian Springs	Service Yard				3	0	Not a picnic unit. Tables used by Metropark staff.	No
Indian Springs	Golf Course				1	0	Not a picnic unit. The Driving Range and Golf Course will be evaluated separately. Two accessible tables needed. Locate off access path to Driving Range / Starter Building.	No
Indian Springs	Golf Course				4	0	Not a picnic unit. The Golf Course and Golf Course Patio will be evaluated separately. Two accessible tables needed.	No
Indian Springs	Equestrian Trail				1	0	Not a picnic unit. This is a remote table located along the equestrian trail.	No

Picnic Unit Ranking Within Metropark

Metropark	Picnic Facility	Picnic Unit Ranking Within Metropark	Picnic Unit Ranking Within Picnic Facility	Picnic Unit Number Within Facility	Number of Tables	Number of Grills	Recommendations	Meets ADA Currently
Stony Creek	Wintercove	1	1	7	17	2	The Wintercove South Picnic Shelter (L) is the most rented shelter in this area. Combine some tables surrounding shelter when calculating necessary accessible tables under shelter. Two accessible grills needed. Walk needed to playground.	No
Stony Creek	Baypoint Beach	2	1	1	21	1	The Baypoint Beach Picnic Shelter (I) is the only rental shelter in this area. Combine some tables surrounding shelter when calculating necessary accessible tables under shelter. Accessible grill needed. Walk needed to hike-bike trail.	No
Stony Creek	West Branch	3	1	1	21	1	The West Branch North Picnic Shelter (M) is the most rented shelter in this area. Meet ADA table ratio under shelter. The grill needs to be accessible. Access walk needed to the restroom building.	No
Stony Creek	Northdale and Southdale	4	1	4	18	1	Southdale Picnic Shelter (A) is most rented shelter in area. Combine some tables surrounding the shelter when calculating necessary accessible tables under shelter. The grill needs to be accessible. Access walks needed to lot and restrooms.	No
Stony Creek	Oakgrove	5	1	2	24	1	Oakgrove North Picnic Shelter (F) is the most rented shelter in area. Combine some tables surrounding shelter when calculating necessary accessible tables under shelter. Accessible grill needed. Walks needed to parking lot and restroom building.	No
Stony Creek	Mount Vernon	6	1	1	21	1	Mount Vernon Picnic Shelter (J) is only rental shelter in area. Combine some tables surrounding shelter when calculating necessary accessible tables under shelter. Accessible grill needed. Walk needed to lot, restroom building, and boat rental.	No
Stony Creek	Wintercove	7	2	1	11	1	Wintercove North Picnic Shelter (K) is second most rented shelter in area. Combine some tables surrounding shelter when calculating accessible tables under shelter. Two accessible grills needed. Walk needed to restrooms and playground.	No
Stony Creek	West Branch	8	2	4	14	1	The West Branch West Picnic Shelter (N) is the second most rented shelter in this area. Meet ADA table ratio under shelter. The grill needs to be accessible. Access walk needed to the restroom building.	No
Stony Creek	Gladeview	9	1	3	16	1	The Gladeview North Picnic Shelter (C) is the most rented shelter in this area. Combine some tables surrounding the shelter when calculating necessary accessible tables under shelter. The grill needs to be accessible.	No

Stony Creek	Northdale and Southdale	10	2	1	24	1	The Northdale Picnic Shelter (B) is the second most rented shelter in this area. Meet ADA table ratio under shelter. The grill needs to be accessible.	No
Stony Creek	Lakeview	11	1	2	11	1	The Lakeview Picnic Shelter (H) is the only rental shelter in this area. Meet ADA accessible table ratio requirements under shelter. The grill needs to be accessible.	No
Stony Creek	Ridgewood	12	1	2	17	1	The Ridgewood Picnic Shelter (G) is the only rental shelter in this area. Meet ADA table ratio under shelter. The grill needs to be accessible.	No
Stony Creek	Gladeview	13	2	4	13	1	The Gladeview South Picnic Shelter (D) is the second most rented shelter in this area. Combine some tables surrounding the shelter when calculating necessary accessible tables under shelter. The grill needs to be accessible.	No
Stony Creek	Oakgrove	14	2	5	12	1	The Oakgrove West Picnic Shelter (E) is the second most rented shelter in this area. The grill needs to be accessible. Accessible walks needed to the parking lot and restroom building.	No
Stony Creek	West Branch	15	3	8	14	1	The West Branch East Picnic Shelter (O) is the least rented shelter in this area. Meet ADA table ratio under shelter. The grill needs to be accessible. Access walk needed to the restroom building.	No
Stony Creek	Wintercove	16	3	8	23	0	Count some tables w/ shelter unit and increase ADA table ratio under shelter. Meet ADA table requirements for the remaining tables. Recommend adding two accessible grills. Locate accessible tables and grills off the existing walk to restrooms.	No
Stony Creek	Northdale and Southdale	17	3	5	4	2	Count some tables w/ shelter unit and increase ADA table ratio under shelter.	No
Stony Creek	Oakgrove	18	3	3	24	1	Count all tables with shelter unit and increase ADA table ratio under shelter. The grill needs to be accessible. An accessible walk is needed to the restroom building.	No
Stony Creek	Mount Vernon	19	2	2	7	1	Count some tables w/ shelter unit and increase ADA table ratio under shelter.	No
Stony Creek	Wintercove	20	4	2	23	0	Count some tables w/ shelter unit and increase ADA table ratio under shelter. Leave the rest as is, won't be an accessible picnic unit.	No
Stony Creek	Gladeview	21	3	2	30	2	Count some tables w/ shelter unit and increase ADA table ratio under shelter. Meet ADA table ratio requirements for remaining tables. The grill needs to be accessible. An accessible walk is needed to the restroom building.	No
Stony Creek	Gladeview	22	4	5	21	1	Count some tables w/ shelter unit and increase ADA table ratio under shelter. Meet ADA table ratio requirements for remaining tables. The grill needs to be accessible. An accessible walk is needed to the restrooms (very difficult).	No
Stony Creek	Eastwood Beach	23	1	1	29	5	Divide this unit into three smaller picnic units with ten tables each. Make one of the three units an accessible unit. Two accessible tables and grills needed within the accessible unit.	No

Stony Creek	Boat Launch	24	1	1	16	4	Four accessible tables needed. Two accessible grills needed.	No
Stony Creek	Eastwood Beach	25	2	2	50	0	Divide this unit into smaller picnic units. Count the tables east of the basketball court with the Northdale / Southdale facility. Meet ADA ratio requirements for remaining tables. Access walk needed to the beach area and restrooms.	No
Stony Creek	Baypoint Beach	26	2	3	22	0	Divide unit into two picnic units. Make one of the units an accessible picnic unit with twenty tables. Four of the tables within the accessible picnic unit will need to be accessible. Locate the accessible tables along the existing walk.	No
Stony Creek	Lakeview	27	2	3	32	5	Divide the picnic unit into three units. Make one of the three an accessible unit with two accessible tables and grills. Locate along a new walk that connects to the restroom building.	No
Stony Creek	Baypoint Beach	28	3	2	28	3	Divide unit into two picnic units. Count some tables w/ shelter unit and increase ADA table ratio under shelter. Meet ADA table ratio requirements for remaining tables. Two grills need to be accessible within the accessible picnic unit.	No
Stony Creek	Lakeview	29	3	4	20	4	Divide the picnic unit into two units. Make the one closest to the play area an accessible unit with two accessible tables and grills. Locate along a new walk that connects to the restroom building.	No
Stony Creek	Mount Vernon	30	3	4	36	7	Divide unit into 3 picnic units. Make one an accessible picnic unit with 15 tables and 3 grills. Three accessible tables and 2 accessible grills needed within accessible picnic unit. Access walks needed to lot, restroom building, and boat rental.	No
Stony Creek	Northdale and Southdale	31	4	7	27	4	Remove two tables from picnic unit. Five accessible tables needed. Two accessible grills needed. Locate accessible tables and grills off a new walk to the restroom building.	No
Stony Creek	Oakgrove	32	4	6	43	6	Divide are into two picnic units. Make one an accessible unit with 20 tables. Four accessible tables and two accessible grills will be needed after dividing. Accessible access walks needed connecting the lot, playground, and restroom building.	No
Stony Creek	West Branch	33	4	3	7	2	Two accessible tables and grills needed. Locate accessible tables and grills off a new walk connecting the shelter, play area, and restroom building.	No
Stony Creek	Mount Vernon	34	4	3	48	8	Divide unit into 3 picnic units. Make one an accessible picnic unit with 15 tables and 3 grills. Three accessible tables and 2 accessible grills needed within accessible picnic unit. Access walks needed to lot, restroom building, and boat rental.	No
Stony Creek	Northdale and Southdale	35	5	2	23	1	Remove three tables from this picnic unit. Four access tables needed. One accessible grill needed. Locate accessible tables and grill along the existing walk to the restroom building and shelter.	No
Stony Creek	Wintercove	36	5	4	17	2	Remove two tables from picnic unit. Three accessible tables and two accessible grills needed after removals. Locate the accessible tables and grills off a new walk to the restroom building.	No

Stony Creek	Oakgrove	37	5	3	8	1	Two accessible tables needed. The grill needs to be accessible. Locate the accessible tables and grill off the existing walk or a new walk to the nearby shelter.	No
Stony Creek	West Branch	38	5	7	9	3	Two accessible tables and grills needed. Locate accessible tables and grills off a new walk connecting the shelter to the restroom building.	No
Stony Creek	West Branch	39	6	6	11	3	Remove one table from picnic unit. Two accessible tables and grills needed after removal. Locate accessible tables and grills off a new walk to the restroom building.	No
Stony Creek	Ridgewood	40	2	1	5	2	Two accessible tables and grills needed. An accessible walk is needed to the restroom building.	No
Stony Creek	Shore Fishing	41	1	1	4	2	Combine picnic units 1 and 2. Two accessible tables and grills needed after combining. Locate the accessible tables and grills off a new walk to the vault latrines.	No
Stony Creek	Shore Fishing	42	2	2	4	2	Combine picnic units 1 and 2. Two accessible tables and grills needed after combining. Locate the accessible tables and grills off a new walk to the vault latrines.	No
Stony Creek	Ridgewood	43	3	3	7	2	Two accessible tables and grills needed. An accessible walk is needed to the restroom building.	No
Stony Creek	Gladeview			1	8	0	Leave as is, won't be an accessible picnic unit.	No
Stony Creek	Lakeview			1	3	0	Leave as is, won't be an accessible picnic unit.	No
Stony Creek	Oakgrove			1	8	1	Leave as is, won't be an accessible picnic unit.	No
Stony Creek	West Branch			2	13	3	Leave as is, won't be an accessible picnic unit.	No
Stony Creek	Northdale and Southdale			3	25	2	Leave as is, won't be an accessible picnic unit.	No
Stony Creek	Wintercove			3	16	3	Leave as is, won't be an accessible picnic unit.	No
Stony Creek	West Branch			5	7	3	Leave as is, won't be an accessible picnic unit.	No
Stony Creek	Wintercove			5	6	1	Leave as is, won't be an accessible picnic unit.	No
Stony Creek	Northdale and Southdale			6	8	3	Leave as is, won't be an accessible picnic unit.	No
Stony Creek	Wintercove			6	9	0	Leave as is, won't be an accessible picnic unit.	No
Stony Creek	Oakgrove			7	17	3	Leave as is, won't be an accessible picnic unit. If area becomes an off-leash dog area and additional accessible picnic unit is recommended.	No
Stony Creek	Northdale and Southdale			8	4	2	Leave as is, won't be an accessible picnic unit.	No
Stony Creek	West Branch			9	5	1	Leave as is, won't be an accessible picnic unit.	No
Stony Creek	Wintercove			9	15	4	Leave as is, won't be an accessible picnic unit.	No
Stony Creek	West Branch			10	7	0	Leave as is, won't be an accessible picnic unit.	No
Stony Creek	Eastwood Beach				14	0	Not a picnic unit. The Food Bar will be evaluated separately. Three accessible tables needed.	No
Stony Creek	Nature Center				9	0	Not a picnic unit. The Nature Center will be evaluated separately. Two accessible tables recommended along the accessible route to the Nature Center. The island area is not accessible.	No
Stony Creek	Osprey Rustic Trail				2	0	Not a picnic unit. This is a trailhead. Two accessible tables recommended.	No

Picnic Unit Ranking Within Metropark

Metropark	Picnic Facility	Picnic Unit Ranking Within Metropark	Picnic Unit Ranking Within Picnic Facility	Picnic Unit Number Within Facility	Number of Tables	Number of Grills	Recommendations	Meets ADA Currently
Wolcott Mill	Farm Center	1	1	2	15	1	The Upper Farm Center Picnic Shelter (A) is the most rented shelter in this area. A 20' section of pavement is needed to create an accessible route to the shelter. The grill needs to be accessible.	No
Wolcott Mill	Farm Center	2	2	4	8	1	The Lower Farm Center Picnic Shelter (B) is the second most rented shelter in this area. An accessible walk is needed to the Farm Center and restrooms. The grill needs to be accessible. Accessible walks needed to the nearby fishing dock.	No
Wolcott Mill	Farm Center	3	3	1	10	0	Two accessible tables needed. Locate near the existing paved walks.	No
Wolcott Mill	Farm Center	4	4	3	9	0	Two accessible tables needed. Locate near the existing paved walks.	No
Wolcott Mill	Historic Center	5	1	3	4	0	Two accessible tables needed.	No
Wolcott Mill	Historic Center	6	2	2	2	0	Two accessible tables needed. Accessible walk needed down to this river location.	No
Wolcott Mill	4H Event Area	7	1	2	1	0	Combine picnic units 1 and 2. Two accessible tables needed when combined. An accessible walk is needed to this sitting area from an accessible parking area. It is unclear where the closest accessible parking spaces are.	No
Wolcott Mill	4H Event Area	8	2	1	2	0	Combine picnic units 1 and 2. Two accessible tables needed when combined. An accessible walk is needed to this sitting area from an accessible parking area. It is unclear where the closest accessible parking spaces are.	No
Wolcott Mill	4H Event Area	9	3	3	2	0	Two accessible tables needed. An accessible walk is needed to this sitting area from an accessible parking area. It is unclear where the closest accessible parking spaces are.	No
Wolcott Mill	Historic Center			1	2	0	Leave as is, won't be an accessible picnic unit.	No
Wolcott Mill	Historic Center			4	2	0	Leave as is, won't be an accessible picnic unit.	No
Wolcott Mill	Historic Center				1	0	Not a picnic unit.	No
Wolcott Mill	North Branch Trails				1	0	Not a picnic unit. An accessible table is recommended.	No
Wolcott Mill	Camp Rotary Group Camp				5	0	Not a picnic unit. Camp Rotary Complex will be evaluated separately.	No
Wolcott Mill	Camp Rotary Group Camp				10	0	Not a picnic unit. Camp Rotary Complex will be evaluated separately.	No
Wolcott Mill	Camp Rotary Group Camp				4	0	Not a picnic unit. Camp Rotary Complex will be evaluated separately.	No
Wolcott Mill	Camp Rotary Group Camp				1	1	Not a picnic unit. Camp Rotary Complex will be evaluated separately.	No
Wolcott Mill	Camp Rotary Group Camp				1	0	Not a picnic unit. Camp Rotary Complex will be evaluated separately.	No

Wolcott Mill	Camp Rotary Group Camp	1	0	Not a picnic unit. Camp Rotary Complex will be evaluated separately.	No
Wolcott Mill	Camp Rotary Group Camp	1	0	Not a picnic unit. Camp Rotary Complex will be evaluated separately.	No
Wolcott Mill	Camp Rotary Group Camp	1	1	Not a picnic unit. Camp Rotary Complex will be evaluated separately.	No
Wolcott Mill	Camp Rotary Group Camp	3	0	Not a picnic unit. Camp Rotary Complex will be evaluated separately.	No
Wolcott Mill	Camp Rotary Group Camp	3	0	Not a picnic unit. Camp Rotary Complex will be evaluated separately.	No
Wolcott Mill	Camp Rotary Group Camp	1	0	Not a picnic unit. Camp Rotary Complex will be evaluated separately.	No
Wolcott Mill	Camp Rotary Group Camp	1	0	Not a picnic unit. Camp Rotary Complex will be evaluated separately.	No
Wolcott Mill	Camp Rotary Group Camp	1	0	Not a picnic unit. Camp Rotary Complex will be evaluated separately.	No
Wolcott Mill	Camp Rotary Group Camp	3	0	Not a picnic unit. Camp Rotary Complex will be evaluated separately.	No
Wolcott Mill	Camp Rotary Group Camp	3	0	Not a picnic unit. Camp Rotary Complex will be evaluated separately. Accessible facility recommended near restroom building.	No
Wolcott Mill	Camp Rotary Group Camp	4	1	Not a picnic unit. Camp Rotary Complex will be evaluated separately. Accessible facility recommended near restroom building.	No
Wolcott Mill	Camp Rotary Group Camp	4	0	Not a picnic unit. Camp Rotary Complex will be evaluated separately. Accessible facility recommended near restroom building. Eliminate the step up to the patio. Access walk planned for fall 2019.	No
Wolcott Mill	Equestrian Staging Area	1	0	Not a picnic unit. Recommend that the table be an accessible table.	No
Wolcott Mill	Model Airplane Field	2	0	Not a picnic unit. Recommend two accessible picnic tables. An accessible path is needed to accessible parking spaces.	No
Wolcott Mill	Historic Center	1	0	Not a picnic unit. Relocate table to a picnic unit.	No
Wolcott Mill	Camp Rotary Service Yard	1	0	Not a picnic unit. Table is used by Metropark staff.	No
Wolcott Mill	North Branch Service Yard	1	0	Not a picnic unit. Table is used by Metropark staff.	No
Wolcott Mill	Camp Rotary Group Camp	12	1	Not a picnic unit. The Camp Rotary Picnic Shelter (C) is the only shelter in this area. An accessible path is needed to the shelter and to the restroom building. An access path from the parking lot to the shelter is planned for fall 2019.	No

Picnic Unit Ranking Within Metropark

Metropark	Picnic Facility	Picnic Unit Ranking Within Metropark	Picnic Unit Ranking Within Picnic Facility	Picnic Unit Number Within Facility	Number of Tables	Number of Grills	Recommendations	Meets ADA Currently
Lake St. Clair	Par-3 Rental Shelter Area	1	1	1	40	2	The Par-3 Picnic Shelter (D) is the only rental shelter in this area. Meet ADA table ratio requirements under shelter. The two existing grills need to be accessible.	No
Lake St. Clair	Seawall Shelter Area	2	1	1	16	1	The Seawall Picnic Shelter (K) is the most rented shelter in this area. The grill needs to be accessible. Access walks needed to the parking lot and nearest restroom building. Parking lot renovation is planned and will change access to shelter.	No
Lake St. Clair	North Marina Shelter Area	3	1	1	12	1	The North Marina Picnic Shelter (L) is the only rental shelter in this area. Meet ADA table ratio requirements under shelter. The grill needs to be accessible.	No
Lake St. Clair	West Beach	4	1	1	12	1	The West Beach Picnic Shelter (D) is the only rental shelter in area. Combine some tables surrounding the shelter when calculating necessary accessible tables under shelter. The grill need to be accessible. Access walk needed to the boardwalk.	No
Lake St. Clair	Daysail	5	1	1	12	1	The Surfside Picnic Shelter (C) is the only rental shelter in this area. Combine some tables surrounding the shelter when calculating necessary accessible tables under shelter. The grill need to be accessible.	No
Lake St. Clair	West Playfield	6	1	1	12	1	The West Playfield Picnic Shelter (A) is the most rented shelter in this area. Meet ADA table ratio requirements under shelter. The existing grill needs to be accessible.	No
Lake St. Clair	Golf Road	7	1	2	12	2	The Golf Road Picnic Shelter (B) is the most rented shelter in this area. Combine all tables surrounding the shelter when calculating necessary accessible tables under shelter. Both grills need to be accessible.	No
Lake St. Clair	East Boardwalk	8	1	3	12	1	Boardwalk Picnic Shelter (G) is most rented shelter in area. Combine some tables surrounding shelter when calculating necessary accessible tables under shelter. Grill needs to be accessible. Access walk needed to boardwalk.	No
Lake St. Clair	East Boardwalk	9	2	1	12	1	The Creek View Picnic Shelter (F) is the second most rented shelter in area. Combine some tables surrounding shelter when calculating necessary accessible tables under shelter. The grill needs to be accessible. Access walks needed.	No
Lake St. Clair	Voyageur Shelter Area	10	1	1	14	1	The Voyageur Picnic Shelter (I) is the only rental shelter in this area. Meet ADA table ratio requirements under shelter. The grill needs to be accessible.	No
Lake St. Clair	Locust Grove Shelter Area	11	1	2	13	1	The Locust Grove Picnic Shelter (H) is the only rental shelter in this area. Combine all tables surrounding shelter when calculating necessary accessible tables under shelter. The grill needs to be accessible. Access walks needed to the restrooms.	No

Lake St. Clair	Huron Point Shelter Area	12	1	1	13	1	The Huron Point Picnic Shelter (J) is the only rental shelter in this area. Meet ADA table ratio requirements under shelter. The grill needs to be accessible.	No
Lake St. Clair	Golf Road	13	2	1	2	0	Count all tables with shelter unit and increase ADA table ratio under shelter.	No
Lake St. Clair	West Beach	14	2	2	24	4	Count some tables w/ shelter unit and increase ADA table ratio under shelter. Meet ADA requirements for remaining tables. Two accessible grills needed. Locate accessible tables and grills off a new walk between the shelter and boardwalk.	No
Lake St. Clair	East Boardwalk	15	3	7	14	3	Count some tables w/ shelter unit and increase ADA table ratio under shelter. Leave as is, won't be an accessible picnic unit.	No
Lake St. Clair	South Marina	16	1	2	9	0	Two accessible tables needed. Locate the accessible tables off the existing walks.	No
Lake St. Clair	Boat Launch	17	1	3	11	0	Remove one table from picnic unit. Two accessible tables needed after removal. Locate the accessible tables along a new walk to the restroom building.	No
Lake St. Clair	Shore Marina	18	1	2	6	0	Two accessible tables needed. Locate the accessible tables off the existing walks.	No
Lake St. Clair	South Marina	19	2	4	10	2	Two accessible tables and grills needed. Locate the accessible tables and grills off the existing walk.	No
Lake St. Clair	Daysail	20	2	3	6	1	Divide unit into two picnic tables. Count some tables w/ shelter unit and increase ADA table ratio under shelter. Two accessible tables and grills needed / recommended within the accessible picnic unit.	No
Lake St. Clair	Boat Launch	21	2	1	9	0	Two accessible tables needed. Locate off the walk to the new floating fishing dock. Accessible route needed to restrooms.	No
Lake St. Clair	Seawall Shelter Area	22	2	2	10	0	Two accessible tables needed. Recommend an accessible grill be added. Access walks needed to the parking lot. Parking lot renovation is planned and will change access to area.	No
Lake St. Clair	Shore Marina	23	2	1	11	0	Remove one table from picnic unit. Two accessible tables needed after removal. Locate the accessible tables along a existing walks. Parking lot reconfiguration proposed that may change this area.	No
Lake St. Clair	North Marina Shelter Area	24	2	2	13	8	Remove three tables from picnic unit. Two accessible tables and grills will be needed after removal. Recommend removing some of the existing grills based on table to grill ratio in the area. Very high number of grills.	No
Lake St. Clair	Locust Grove Shelter Area	25	2	1	10	2	Two accessible tables and grills needed. Locate the accessible tables and grills off the existing walk.	No
Lake St. Clair	West Playfield	26	2	2	2	1	Two accessible tables needed. One accessible grill needed.	No
Lake St. Clair	Voyageur Shelter Area	27	2	3	5	0	Combine picnic units 2 and 3. Three accessible tables and two accessible grills needed after combining. Locate the accessible tables and grills off the existing walk with access to the restroom building.	No

Lake St. Clair	Voyageur Shelter Area	28	3	2	8	4	Combine picnic units 2 and 3. Three accessible tables and two accessible grills needed after combining. Locate the accessible tables and grills off the existing walk with access to the restroom building.	No
Lake St. Clair	Daysail	29	3	5	4	0	Two accessible picnic tables needed. Two accessible grills recommended. Locate the accessible tables and grills off a proposed hike-bike trail that will eventually extend around the parking lot.	No
Lake St. Clair	East Boardwalk	30	4	2	41	7	Divide this large picnic unit into two smaller units. Count some tables w/ shelter unit and increase ADA table ratio under shelter. Make one of the units an accessible unit with 20 tables. Four accessible tables and grills needed within this unit.	No
Lake St. Clair	East Boardwalk	31	5	4	19	2	Four accessible tables needed. Both grills need to be accessible.	No
Lake St. Clair	South Marina			1	11	0	Leave as is, won't be an accessible picnic unit.	No
Lake St. Clair	Boat Launch			2	4	0	Leave as is, won't be an accessible picnic unit.	No
Lake St. Clair	Daysail			2	2	0	Leave as is, won't be an accessible picnic unit.	No
Lake St. Clair	Shore Marina			3	2	0	Leave as is, won't be an accessible picnic unit.	No
Lake St. Clair	South Marina			3	8	0	Leave as is, won't be an accessible picnic unit.	No
Lake St. Clair	Daysail			4	2	0	Leave as is, won't be an accessible picnic unit.	No
Lake St. Clair	East Boardwalk			5	4	2	Leave as is, won't be an accessible picnic unit.	No
Lake St. Clair	East Boardwalk			6	14	3	Leave as is, won't be an accessible picnic unit.	No
Lake St. Clair	Locust Grove Shelter Area				1	0	Not a picnic unit. Count all table with shelter unit and increase ADA table ratio under shelter.	No
Lake St. Clair	Par-3 Golf Building				2	0	Not a picnic unit. The Par-3 Rental Building will be evaluated separately. Two accessible tables needed. Can likely unbolt one of the existing seats to make both accessible.	No

APPENDIX 5: PLAYGROUND TRANSITION PLAN



PLAYGROUND INVENTORY

Park	Total Playgrounds	With Paved Route	Percentage
Lake St. Clair	2	1	50%
Lake Erie	2	1	50%
Oakwoods	0	0	null
Willow	11	2	18%
Lower Huron	12	3	25%
Delhi	5	1	20%
Dexter-Huron	3	0	0%
Hudson Mills	7	1	14%
Huron Meadows	2	1	50%
Kensington	23	6	26%
Indian Springs	5	5	100%
Stony Creek	14	1	7%
Wolcott Mill	1	0	0%

LARGE PLAYGROUNDS

Playground Accessibility	Kensington Martindale Beach	Kensington Maple Beach	Hudson Mills Activity Center 2-5	Hudson Mills Activity Center 5-12	Indian Springs Meadowlark	Indian Springs Adventure Climbing	Indian Springs Adventure Play	Huron Meadows Sunset Ridge	Lower Huron Ellwoods	Willow Tot Lot	Lake Erie Great Wave	Lake Erie Cove Point	Stony Creek Eastwood Beach	Wolcott Mill Farm Center	Lake St. Clair Tot Lot
Is there a handicap van accessible parking space nearby, with sign?	Yes	No	No	No	Yes	No	No	No	Yes	Yes	Yes	Yes	Yes	No	Yes
Is there an accessible route to the playground?	Yes	Yes	Yes	Yes	Yes	Yes	Yes	Yes	No	Yes	Yes	Yes	Yes	Yes	Yes
Does the play surface comply with standards, including being maintained and even?	Yes	Yes	Yes	Yes	Yes	Yes	Yes	Yes	Yes	Yes	Yes	Yes	Yes	Yes	Yes
Is there a ramped transition from accessible route into the mulch play area?	No	No	Yes	Yes	No	No	No	Yes	No	Yes	No	No	Yes	Yes	No
Does the play structure have a transfer station or ramp to allow access onto the structure?	Yes	Yes	Yes	No	Yes	No	-	Yes	No	No	Yes	Yes	Yes	No	No
Does it appear the structure was designed for accessibility? Accessible elements must be dispersed at upper and lower levels.	Yes	Yes	Yes	Yes	Yes	Yes	Yes	Yes	No	Yes	Yes	Yes	Yes	No	No
Rank	3	3	3	3	3	2	3	3	2	3	3	3	4	2	2

APPENDIX 6: PROGRAMMING TRANSITION PLAN



APPENDIX 7: PUBLIC INPUT SUMMARY



